

R2KA 24 /20

Submittal



R2KA 24/20 is premier premix gas-fired combination boiler that complies with ANSI Z21.13 and CSA 4.9 GAS FIRED LOW PRESSURE STEAM AND HOT WATER BOILERS. The R2KA 24/20 models are equipped Combi-Tech® stainless steel heat exchanger that consists of a single tube coil with a diameter of 28 mm. The Combi-Tech Combi-Tech® stainless steel heat exchanger that consists of an outer tube coil with a diameter of 28 mm and integrated with the outer coil is an inner coil for the production of DHW. The Combi-Tech design along with an indirect tank, combined together forms the DUALTECH design. DHW is heated first by entering the Combi-Tech® exchanger and then by the indirect tank providing generous amounts of hot water at the desired temperature instantaneously. DUALTECH design produces lesser emissions, increased energy savings and produces higher efficiencies making the DUALTECH design the ideal response for those who do not accept compromises in performance, reliability and efficiency.

MAIN FEATURES

ANTI-FREEZE FUNCTION PROTECTION

OUTDOOR RESET

WIDE MODULATING RANGE

LOW NOX EMISSIONS

AUTOMATIC BY-PASS FITTED

PRE-WIRED ELECTRICAL LEAD

FULL GAS/AIR MODULATION

MIXED ZONE CARD (OPTIONAL)

SOLAR CARD CONTROL (OPTIONAL)

TIME AND TEMPERATURE CONTROLLERS (OPTIONAL)

TECHNICAL FEATURES

MODEL	R2KA 24 /20	
Maximum central heating input	btu/h - (kW)	88716 - (26)
Maximum domestic hot water input	btu/h - (kW)	98952 - (29)
Minimum central heating input	btu/h - (kW)	13650 - (4)
Minimum domestic hot water input	btu/h - (kW)	13650 - (4)
Adjustable central heating range	°F - (°C)	86-167 / 77-113 (30-75 / 25-45)
Maximum operating temperature for central heating	°F - (°C)	203 - (95)
Maximum operating pressure for central heating	psi - (bar)	60 - (4.1)
Capacity of the system expansion vessel	gal(US) - (litres)	2.64 - (10)
Domestic hot water temperature range	°F - °C	95-140 (35-60)
Maximum pressure for domestic hot water	psi - (bar)	150 - (10.34)
Minimum pressure for domestic hot water	psi - (bar)	7.25 - (0.5)
Storage tank capacity	gal(US) - (litres)	5.28 - (20)
Continuous hot water flow rates (1 hour): ΔT 54°F (30°C)	gal(US) - (litres)	224.57 - (850)
Continuous hot water flow rates (1 hour): ΔT 77°F (43°C)	gal(US) - (litres)	170.41 (645)
Hot water flow rates (first 10 minutes): ΔT 54°F (30°C)	gal(US) - (litres)	41.74 (158)
Hot water flow rates (first 10 minutes): ΔT 77°F (43°C)	gal(US) - (litres)	30.4 - (115)
Width	in - (mm)	19.29 - (490)
Depth	in - (mm)	19.7 - (500)
Height	in - (mm)	35.43 - (900)
Gross weight	lb - (Kg)	139 - (63)
Electric consumption - normal	W	78
Electric consumption - Standby	W	3.5
AFUE Rating	%	96

WARRANTY HEAT EXCHANGER: 12 YEARS;

WARRANTY COMPONENTS: 2 YEARS.

PROJECT NO.:

REPRESENTATIVE:

NAME:

DATE:

LOCATION:

SPECIFIER:

APPROVED BY:

CONTRACTOR:

DATE:





1. R2KA 24 /20 SUBMITTAL

OVERALL DIMENSIONS (INCH)

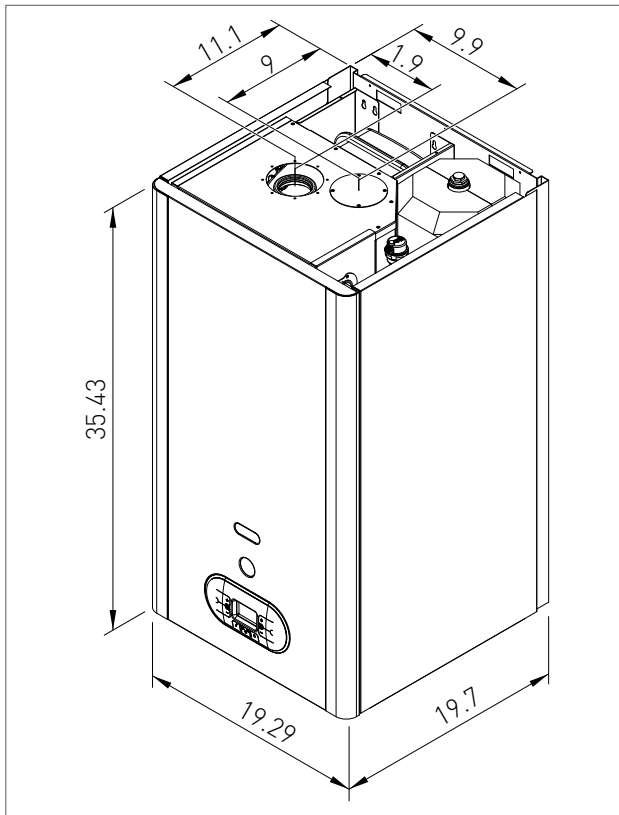

TYPES OF EXHAUST SYSTEMS

- > COLLINEAR VENT, CO-AXIAL VENT AND SINGLE VENT.
- > PVC, CPVC AND POLYPROPYLENE FOR SIZES 2", 3" AND 4" DIAMETERS.
- > FOR CANADA USE GAS VENTING SYSTEMS CERTIFIED TO ULC S636.

CIRCULATOR PREVALENCE/FLOW DIAGRAM

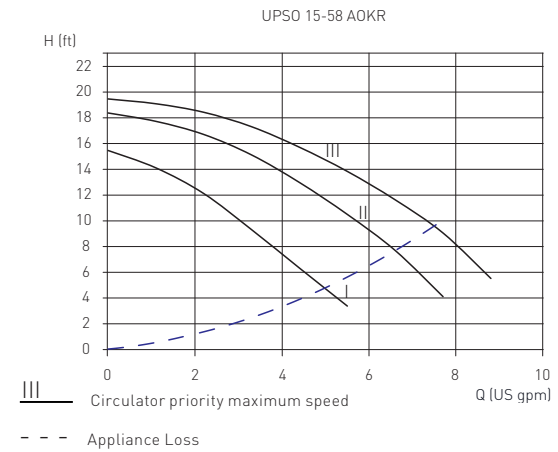

JIG

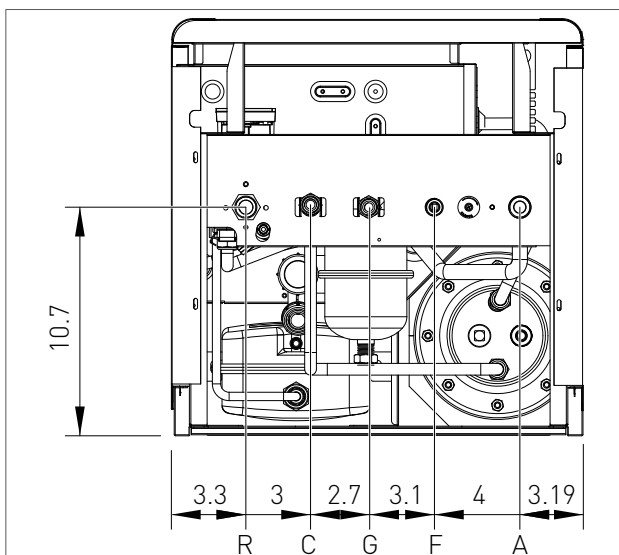

- R - CENTRAL HEATING RETURN \varnothing 3/4" *
- C - DOMESTIC HOT WATER OUTLET \varnothing 1/2" *
- G- GAS \varnothing 1/2" *
- F - COLD WATER INLET \varnothing 1/2" *
- A - CENTRAL HEATING SUPPLY \varnothing 3/4" *

HYDRAULIC CONNECTION KIT

An hydraulic kit equipped is supplied by RADIANT.

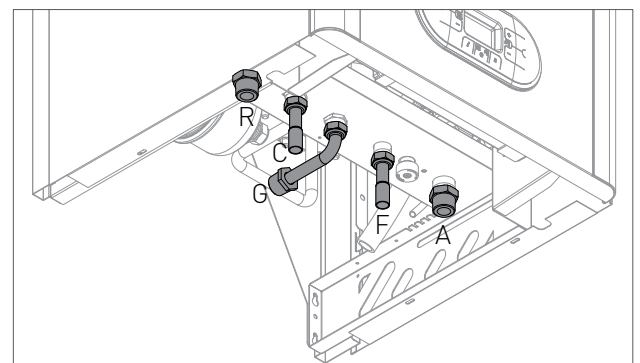

- R - CENTRAL HEATING RETURN \varnothing 3/4" NPT
- C - DOMESTIC HOT WATER OUTLET \varnothing 1/2" SWEAT
- G- GAS \varnothing 3/4" NPT
- F - COLD WATER INLET \varnothing 1/2" SWEAT
- A - CENTRAL HEATING SUPPLY \varnothing 3/4" NPT

(*) NOTE: THESE ARE CONNECTION SIZES BEFORE CONNECTION CONVERSION KIT IS INSTALLED.



TECHNICAL ASSEMBLY

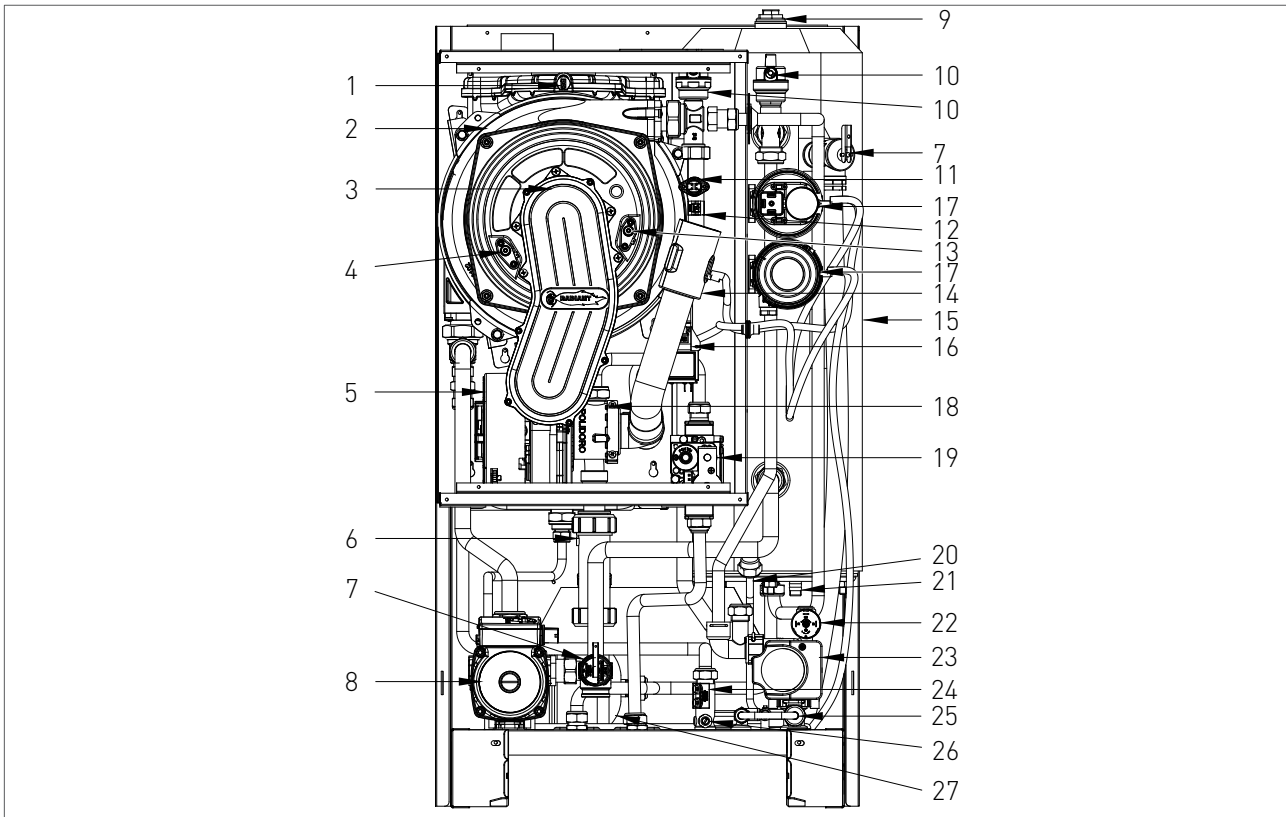

KEY

- | | |
|---|-----------------------------------|
| 1. EXHAUST SAFETY HIGH LIMIT SWITCH | 23. DIVERTER VALVE |
| 2. INTEGRATED HEAT EXCHANGER | 24. FLOW SWITCH |
| 3. BURNER UNIT | 25. CHECK VALVE |
| 4. IONIZATION ELECTRODE | 26. FLOW LIMITER |
| 5. COMBUSTION BLOWER | 27. THERMAL EXPANSION TANK D.H.W. |
| 6. CONDENSATE COLLECTION SIPHON | |
| 7. PRESSURE RELIEF VALVE | |
| 8. CIRCULATOR | |
| 9. ANODE | |
| 10. AIR ELIMINATOR | |
| 11. WATER TEMPERATURE HIGH LIMIT SWITCH | |
| 12. CENTRAL HEATING TEMPERATURE PROBE | |
| 13. SPARK ELECTRODE | |
| 14. AIR SUCTION TUBE | |
| 15. INDIRECT TANK | |
| 16. IGNITION TRANSFORMER | |
| 17. AIR PRESSURE SWITCH | |
| 18. PROPORTIONAL VENTURI | |
| 19. GAS VALVE | |
| 20. BY-PASS | |
| 21. TANK DRAINING TAP | |
| 22. WATER PRESSURE SWITCH | |

HYDRAULIC BOARD

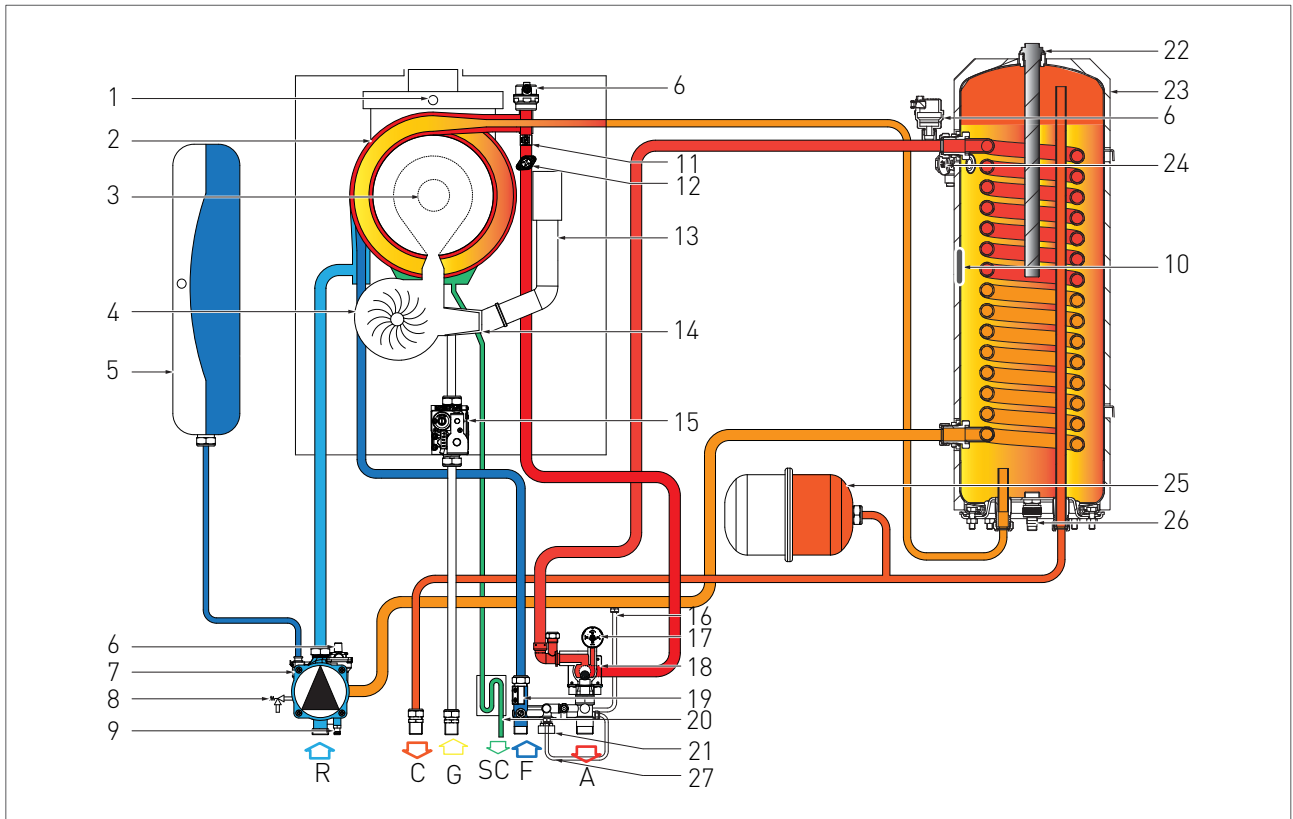

KEY

- | | |
|---|--|
| R. CENTRAL HEATING RETURN | 11. CENTRAL HEATING TEMPERATURE PROBE |
| C. DOMESTIC HOT WATER OUTLET | 12. WATER TEMPERATURE HIGH LIMIT SWITCH |
| G. GAS INLET | 13. AIR SUCTION TUBE |
| SC. CONDENSATE DRAIN | 14. PROPORTIONAL VENTURI |
| F. COLD WATER INLET | 15. GAS VALVE |
| A. CENTRAL HEATING SUPPLY | 16. BY-PASS |
| 1. EXHAUST SAFETY HIGH LIMIT SWITCH | 17. WATER PRESSURE SWITCH |
| 2. INTEGRATED HEAT EXCHANGER | 18. DIVERTER VALVE |
| 3. BURNER UNIT | 19. FLOW SWITCH |
| 4. COMBUSTION BLOWER | 20. CONDENSATE COLLECTION SIPHON |
| 5. THERMAL EXPANSION TANK | 21. SYSTEM FILLING TAP |
| 6. AIR ELIMINATOR | 22. ANODE |
| 7. CIRCULATOR | 23. INDIRECT TANK |
| 8. PRESSURE RELIEF VALVE 30 psi [2 bar] | 24. PRESSURE RELIEF VALVE 150 psi [10.3 bar] |
| 9. SYSTEM DRAINING TAP | 25. THERMAL EXPANSION TANK D.H.W. |
| 10. DOMESTIC TEMPERATURE PROBE | 26. TANK DRAINING TAP |
| | 27. CHECK VALVE |



WIRING DIAGRAM

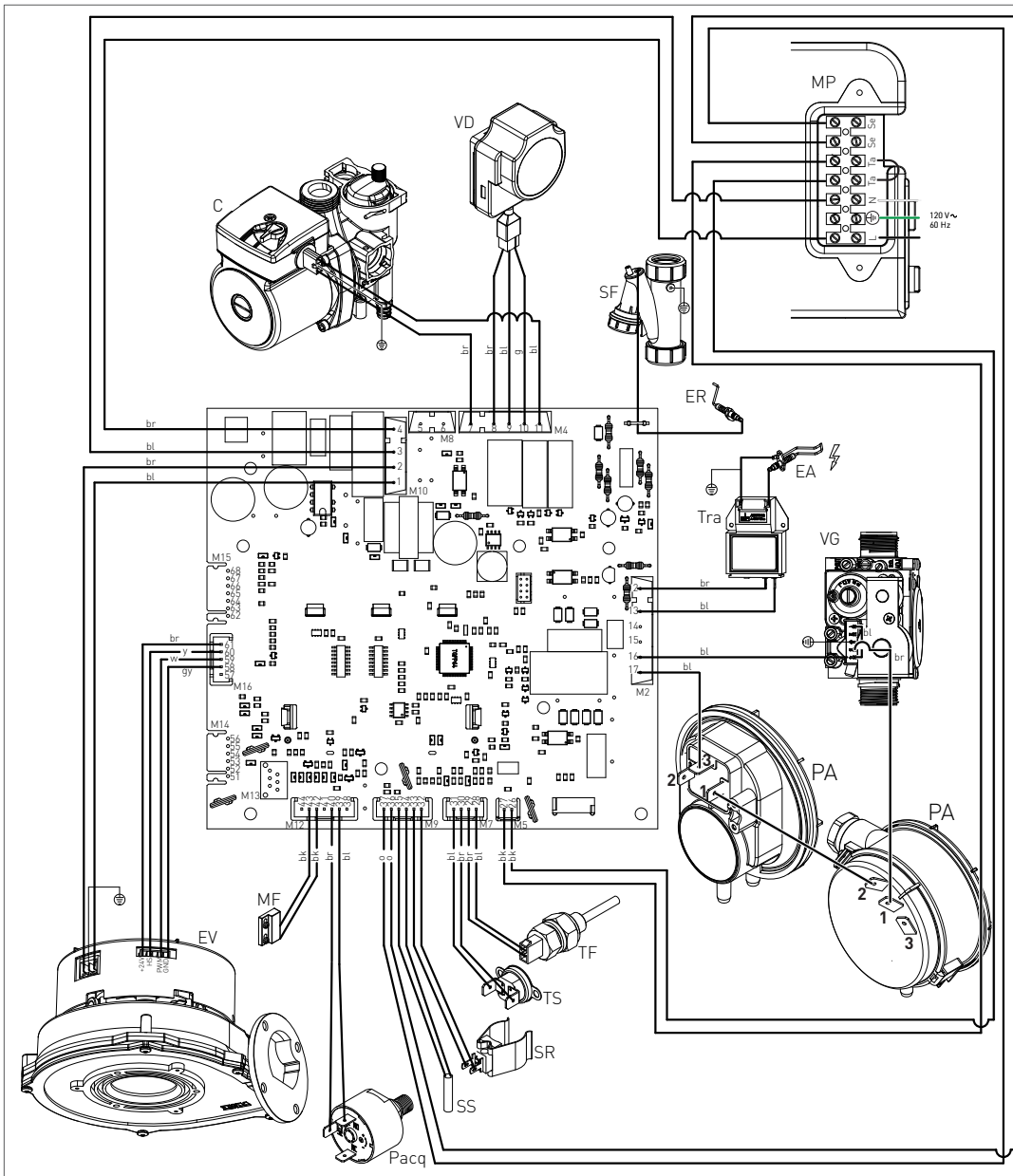

- | | | | |
|--|---|----------------------------|----------------------------------|
| ER: IONIZATION ELECTRODE | TS: WATER TEMPERATURE HIGH LIMIT SWITCH | MP: PANEL TERMINAL | BL: BLUE |
| EA: SPARK ELECTRODE | PACQ: WATER PRESSURE SWITCH | SE: OUTDOOR TEMPERATURE | BR: BROWN |
| C: CIRCULATOR | MF: MICRO-FLOW SWITCH | TA: ENVIRONMENT THERMOSTAT | O: ORANGE |
| VG: GAS VALVE | SR: CENTRAL HEATING TEMPERATURE PROBE | L: LINE | Y: YELLOW |
| TRA: IGNITION TRANSFORMER | SS: DOMESTIC TEMPERATURE PROBE | N: NEUTRAL | W: WHITE |
| TF: EXHAUST SAFETY HIGH LIMIT SWITCH (102°C) | EV: COMBUSTION BLOWER | BK: BLACK | GY: GREY |
| VD: DIVERTER VALVE | PA: AIR PRESSURE SWITCH | G: GREEN | SF: CONDENSATE COLLECTION SIPHON |