



Installation and Maintenance Manual for model

R2KA 34 /20



WARNING

If the information in these instructions is not followed exactly, a fire or explosion may result causing property damage, personal injury or death.

FOR YOUR SAFETY

— Do not store or use gasoline or other flammable vapors and liquids in the vicinity of this or any other appliance.

— WHAT TO DO IF YOU SMELL GAS

- Do not try to light any appliance.
- Do not touch any electrical switch; do not use any phone in your building.
- Immediately call your gas supplier from a neighbor's phone. Follow the gas supplier's instructions.
- If you cannot reach your gas supplier, call the fire department.

— Installation on and service must be performed by a qualified installer, service agency or the gas supplier.





SUMMARY

INTRODUCTION 4

1. INSTALLER SECTION 7

1.1. INSTALLATION 8

1.1.1. GENERAL INSTALLATION WARNINGS 8

1.1.2. BOILER LOCATION ENVIRONMENTAL REQUIREMENTS 8

1.1.3. REFERENCE LEGISLATION 9

1.1.4. UNPACKING 10

1.1.5. OVERALL DIMENSIONS (inch) 11

1.1.6. PIPING LAYOUT/IDENTIFICATION 11

1.1.7. HYDRAULIC CONNECTION KIT 11

1.1.8. POSITIONING AND CLEARANCES TO COMBUSTIBLE MATERIAL AND SERVICE CLEARANCES 12

1.1.9. CIRCULATOR PERFORMANCE CURVES 13

1.1.10. WATER CONNECTIONS 14

1.1.11. D.H.W. CIRCULATING LOOP 15

1.1.12. SYSTEM FILLING 16

1.1.13. FILLING THE CONDENSATE COLLECTION SIPHON 17

1.1.14. ANTI-FREEZE PROTECTION 19

1.1.15. GAS CONNECTION 20

1.1.16. ELECTRICAL CONNECTION 20

1.1.17. POWER SUPPLY 21

1.1.18. OPTIONAL ELECTRICAL CONNECTIONS 22

1.1.19. VENTING 24

1.1.20. TYPES OF EXHAUST SYSTEMS 27

1.1.21. TABLE 1: ALLOWABLE VENT LENGTHS 32

2. SUPPORT CENTRE SECTION 35

2.1. FIRST START-UP 36

2.1.1. PRELIMINARY OPERATIONS FOR FIRST START-UP 36

2.1.2. BOILER COMMISSIONING 37

2.1.3. CO2 VALUE CHECK AND CALIBRATION 38

2.1.4. ACCESSING AND PROGRAMMING THE PARAMETERS 39

2.1.5. DIGITECH CS (MIAH402) PARAMETERS TABLE 41

2.1.6. COMBUSTION BLOWER FREQUENCY/HEAT CAPACITY DIAGRAM 49

2.2. MAINTENANCE 50

2.2.7. GENERAL MAINTENANCE WARNINGS 50

2.2.8. TECHNICAL DATA 51

2.2.9. TECHNICAL ASSEMBLY TECHNICAL ASSEMBLY 53

2.2.10. INTERNAL PIPING SCHEMATIC 54



2.2.11. 3-WAY VALVE OPERATION.....	55
2.2.12. WIRING DIAGRAM.....	56
2.2.13. ACCESSING THE BOILER.....	57
2.2.14. ACCESSING THE ELECTRONIC BOARD.....	58
2.2.15. SYSTEM EMPTYING.....	59
2.2.16. BOILER MAINTENANCE.....	60
2.2.17. FAULT SIGNALLING CODES.....	61
2.2.18. ACTIVE FUNCTIONS SIGNALLING CODES.....	64
2.2.19. CONVERSION TO A DIFFERENT GAS TYPE.....	65
2.2.20. POSITIONS OF THE ELECTRODES.....	66

INTRODUCTION

WARNING

Before starting any operation it is mandatory to read this instruction manual, in relation to the activities performed as described in each relevant section. Proper operation and optimal performance of the boiler are ensured by strict compliance with all the instructions given in this manual.

The installation, use and maintenance manual is an integral and essential part of the product and must be delivered to the user.

MANUAL USERS

The manual users are all those who install, use and maintain the boiler.

The boiler must be used and accessed only by qualified operators that fully read and understood the use and maintenance manual, paying particular attention to the warnings.

READING AND SYMBOLS OF THE MANUAL

To ease the understanding of this manual, recurrent symbols where used, in particular:

- › On the outer margin of the page is placed a thumb index indicating the type of user to which the instructions in that section address.
- › The titles are differentiated by thickness and size in accordance with their hierarchy.
- › The images contain important parts described in the text, marked with numbers or letters.
- › (See chap "chapter# name"): this entry indicates another section in the Manual that you should refer to.
- › Device: this term is used referring to the boiler.



DANGER

It identifies information related to a general danger that if not complied with, may cause serious personal damage or even death.



ATTENTION

It identifies information that if not complied with may cause small or medium level burns to the person or serious damage to the boiler.



WARNING

It identifies a precaution information that must be observed in order to avoid damaging the machine or various parts.

MANUAL STORAGE

The manual must be stored carefully and replaced in case of deterioration and/or low legibility.

If you misplace the use and maintenance manual, you can request a copy from the Technical Support Center. It is important to provide the model number and serial number of the unit which is found on the inside surface of the right panel.



MANUFACTURER WARRANTY AND RESPONSIBILITY

The Manufacturer's warranty is provided only through its own authorized Technical Support Centers, listed for each Region on the site www.radianthydronics.com, and covers all manufacturing defects at the time of sale.

The technical and functional features of the unit are ensured when proper installation and maintenance is carried out. Conditions of Manufacturer's warranty includes the following:

1. The customer is aware of and follows instructions contained in the manuals that accompany the product.
2. Annual service check up is required to keep warranty valid.
3. The unit is installed and operated in the conditions in which it is designed to.

For more information on the warranty validity, its duration, the obligations and the exemptions, please consult the First start-up certificate attached to this manual.

The manufacturer reserves:

- › the right to modify the tools and relative technical documentation without any obligation to third parties;
- › the material and intellectual ownership of this manual and forbids its distribution and duplication, even partial, without prior written authorization.

PRODUCT CONFORMITY

RADIANT BRUCIATORI spa with reference to ANSI Z21.13-2017 • CSA 4.9-2017 GAS FIRED LOW PRESSURE STEAM AND HOT WATER BOILERS, declares that its gas boilers are professionally manufactured.

The materials used such as copper, brass, stainless steel create a homogeneous, compact and functional assembly, easy to install and maintain. The boiler is equipped with all accessories necessary to provide a dependable independent heating unit. All boilers are tested and delivered with a quality certificate signed by the testing department.



1. INSTALLER SECTION

The installation operations described in this section should be performed only by qualified personnel, having the appropriate technical training in the field for the installation and maintenance of components of civil and industrial domestic hot water production and heating plants.



1.1. INSTALLATION

1.1.1. GENERAL INSTALLATION WARNINGS

This boiler must be installed in accordance with local codes, if any; if not, follow the National Fuel Gas Code, ANSI Z223.1/NFPA 54, or the Natural Gas and Propane Installation Code, CAN/CSA B149.1, as applicable.



WARNING

This unit may be used only for the purpose for which it has been designed: heat water to a temperature below boiling point at atmospheric pressure. Any other use is considered wrong and dangerous. The manufacturer is excluded from any contractual or out of contract responsibility for damage caused to people, animals or property due to errors during installation.



WARNING

This boiler should be installed only by qualified service technician, having the appropriate technical training in the field for the installation and maintenance of components of civil and industrial domestic hot water production and heating plants.



WARNING

After having removed the packing, make sure the equipment is intact. In case of doubt, do not use the equipment and contact the supplier.

BEFORE INSTALLING THE BOILER, THE INSTALLER MUST MAKE SURE THAT THE FOLLOWING CONDITIONS ARE PRESENT:

- › The unit is connected to a heating plant and a water supply network appropriate for its power and performance.
- › The location must be properly vented through an air vent.

The air vent must be placed at floor level to prevent it from being obstructed, protected by a grid that does not hamper air flow.

- › The unit is suitable for use with the type of gas available by checking the boiler data plate placed on the inner side of the front casing.
- › Make sure that the gas lines are properly sealed without any gas leaks.
- › Make sure that the grounding system works properly.
- › Make sure that the electrical system is suitable for the maximum power required by the equipment, value indicated on the data plate.



WARNING

Use only original RADIANT optional or kit accessories (including electrical).

1.1.2. BOILER LOCATION ENVIRONMENTAL REQUIREMENTS

The boiler shall be installed so the gas ignition system components are protected from water (dripping, spraying, rain, etc.) during appliance operation and service (circulator replacement, condensate trap, control replacement, etc.).

The boiler installed using inside air supply must provide provisions for Combustion Air and Ventilation Air in accordance with section 5.3, Air for Combustion and Ventilation, of the National Fuel Gas Code, ANSI Z 223,1/NFPA 54, or section 7.2, 7.3, or 7.4, of CAN/CSA B 149, Installation Codes, or local codes having jurisdiction.

Where an exhaust fan or any other air consumption appliance is installed in the same space as the



boiler, sufficient air openings must be available to provide fresh air when all appliances are operating simultaneously. It is essential that in rooms where the boiler is installed to provide as much air as required by normal combustion of the gas consumed by the various appliances. Consequently, it may be necessary to make openings in the walls to provide air inlet into the rooms.

Application where air from the structure is used to supply combustion air for the unit, the following openings are required:

1. Have a total free section of at least 25 mm² every kW (1 in² for every 1000 Btu/hr) of heat input, with a minimum of 100 cm² (15.5 in²);
2. Where required by code or when required for additional opening must be provided at the highest practical elevation.

With a hermetically sealed combustion chamber and air supply circuit from outdoors, the boiler may be installed in any room in the home. Keep boiler area clear and free from combustible materials, gasoline and other flammable vapors and liquids.

**WARNING**

If the temperature in the boiler installation location goes below 14°F centigrades, please fill the system with anti-freeze liquid and insert and electrical resistances kit (see 1.1.14 'ANTI-FREEZE PROTECTION').

1.1.3. REFERENCE LEGISLATION

This boiler must be installed in accordance with local codes, if any; if not, follow the National Fuel Gas Code, ANSI Z223.1/NFPA 54, or the Natural Gas and Propane Installation Code, CAN/CSA B149.1, as applicable.



1. INSTALLATION

1.1.4. UNPACKING



WARNING

Please unpack the boiler just before installing it. The Company is not responsible for the damages caused to the device due to incorrect storage.



WARNING

The packing elements (cardboard box, wooden crate, nails, fasteners, plastic bags, expanded polystyrene, etc.) are dangerous and must be kept out of the reach of children, they should be discarded properly.

To unpack the boiler, proceed as follows:

- > Place the packed boiler on the floor (fig. 1-A) and remove the fasteners opening the four flaps of the box outwards.
- > Turn the boiler at 90° holding it with your hand (fig. 1-B).
- > Lift the box (fig. 1-C) and remove the guards (fig. 1-D).

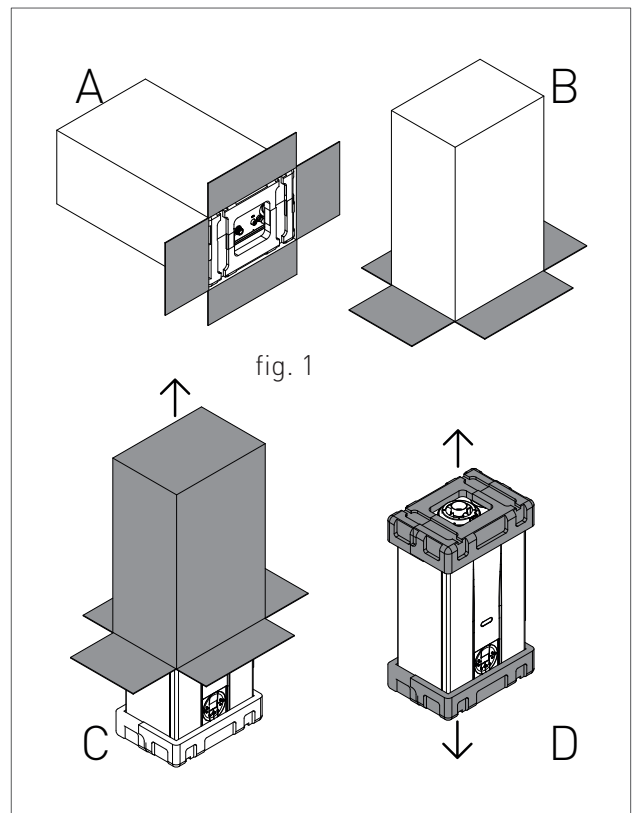



1.1.5. OVERALL DIMENSIONS (inch)

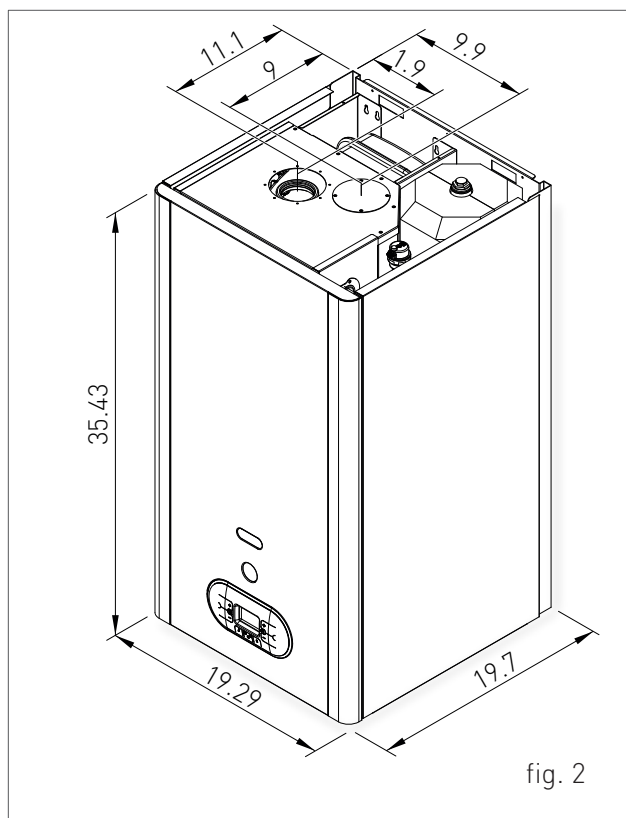

fig. 2

1.1.6. PIPING LAYOUT/IDENTIFICATION

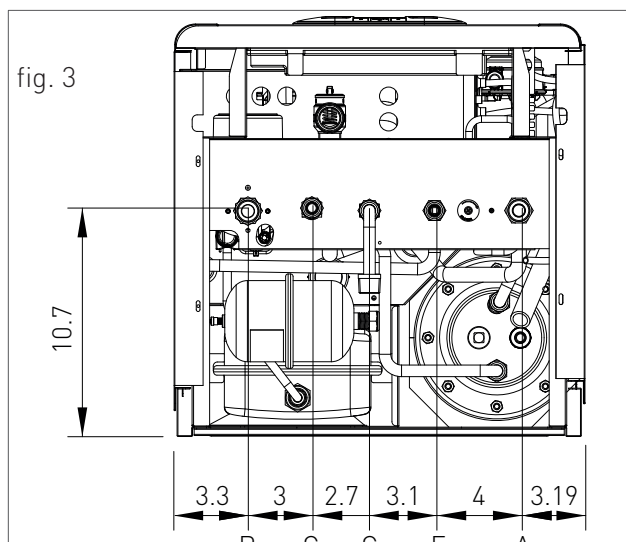

fig. 3

- R - CENTRAL HEATING RETURN \varnothing 3/4" *
- C - DOMESTIC HOT WATER OUTLET \varnothing 1/2" *
- G- GAS \varnothing 1/2" *
- F - COLD WATER INLET \varnothing 1/2" *
- A - CENTRAL HEATING SUPPLY \varnothing 3/4" *

1.1.7. HYDRAULIC CONNECTION KIT

An hydraulic kit equipped is supplied by RADIANT (see fig.4).

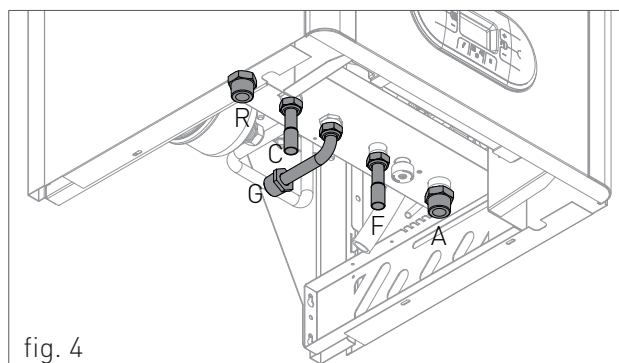

fig. 4

- R - CENTRAL HEATING RETURN \varnothing 3/4" NPT
- C - DOMESTIC HOT WATER OUTLET \varnothing 1/2" SWEAT
- G - GAS \varnothing 3/4" NPT
- F - COLD WATER INLET \varnothing 1/2" SWEAT
- A - CENTRAL HEATING SUPPLY \varnothing 3/4" NPT

(*) NOTE: THESE ARE CONNECTION SIZES BEFORE CONNECTION CONVERSION KIT IS INSTALLED.

1.1.8. POSITIONING AND CLEARANCES TO COMBUSTIBLE MATERIAL AND SERVICE CLEARANCES

The boiler must be installed only on a vertical solid wall, able to sustain its weight.

This boiler has been certified to be installed with "0" clearances to combustible material.

In order to allow the access inside the boiler for maintenance operations, follow the minimum service clearances indicated in figure 5.

To facilitate the installation, the boiler is provided with a jig that allows setting in advance the connections to the tubes providing the ability of connecting the boiler to completed masonry structure.

To position the unit, proceed as follows (see fig. 6):

1. Trace a line using a spirit level (min. length 9.8 inch) on the installation wall.
2. Place the top of the jig along the traced line respecting the distances of the water connections; then mark the two points to insert the fasteners, then trace the points for the exhaust vent;
3. Remove the jig and drill the wall;
4. Fix the wall bracket using the screws provided. Hang the unit on the bracket.

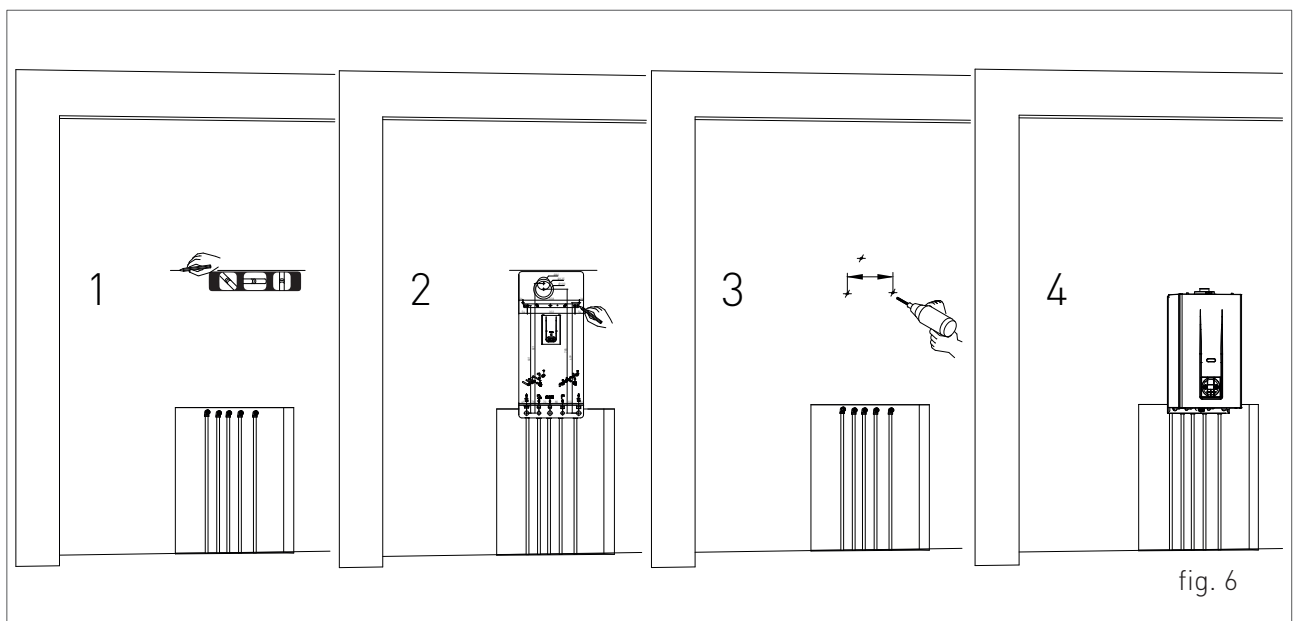
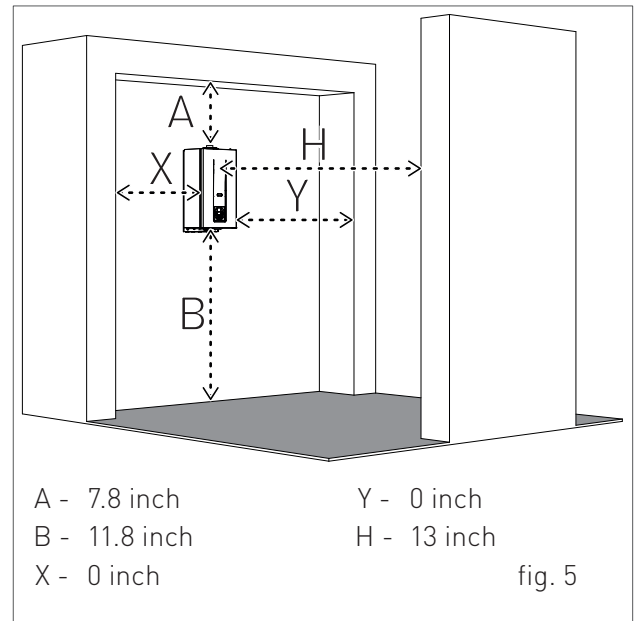



WARNING

To ensure condensate properly drains from the heat exchanger, and avoid any issues that may arise from the stagnation of the condensate within the product itself, it is extremely important that the unit is mounted BOTH level and plumb to the wall (as per figure 7).

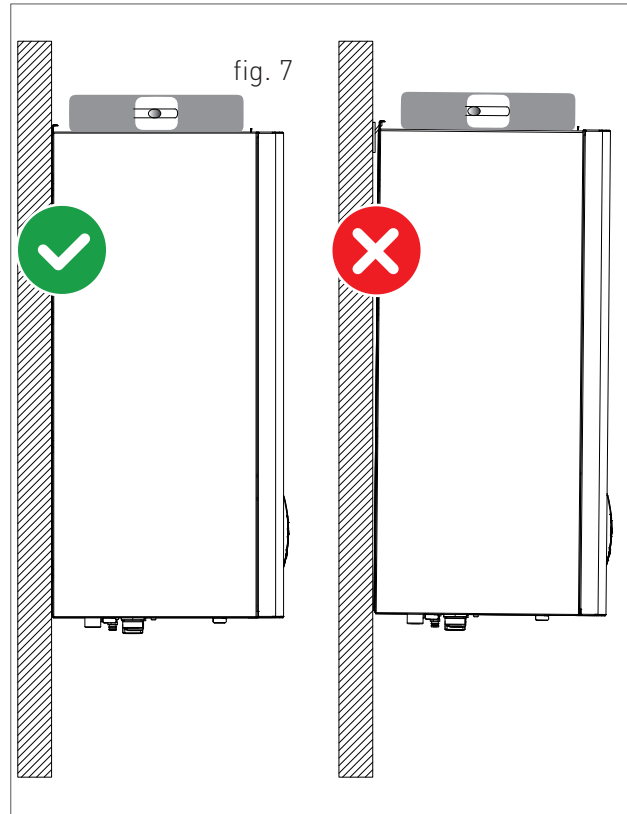

1.1.9. CIRCULATOR PERFORMANCE CURVES

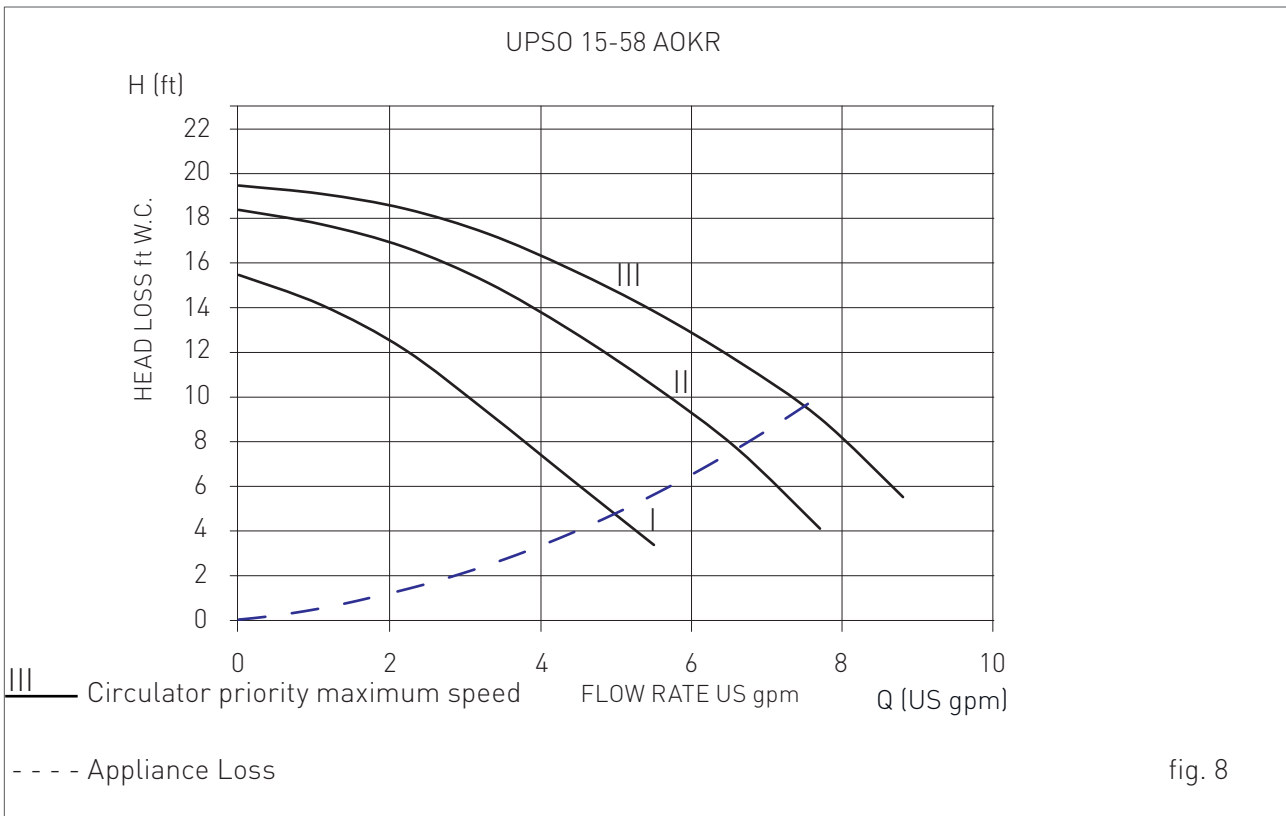



1. INSTALLATION

1.1.10. WATER CONNECTIONS



DANGER

Make sure that the tubes of the water and heating unit are not used as grounding system for the electrical unit. There are not suitable for such use.



WARNING

To prevent voiding the warranty and to ensure the proper operation of the boiler, wash the unit (if possible when hot) with suitable descaling solution to remove the impurities coming from tubes and radiators.



WARNING

If the boiler is installed in a hydrostatic position lower than those of the user devices (radiators, fan coils, etc.), mount the shut-off valves on the domestic water heating circuit to ease the performance of the maintenance operations if necessary to only empty the boiler.



WARNING

When connecting the equipment to water supply, avoid excessive bending and recovery operations from improper positioning that may damage the tubes causing leaks, malfunction or premature wear.



WARNING

In order to avoid any vibrations and noises, do not use tubes with small diameters or elbows with small radius and significant cut-off of the passage sections.

DOMESTIC CIRCUIT

In order to prevent limestone build-up and damages to the domestic water heat exchanger, the hardness of the domestic supply water should not exceed 8.4° dh (degrees hardness). However, please check the characteristics of the water used and install suitable treating devices.

The heat exchanger coil cleaning frequency depends on the hardness of the supply water and on the presence of solid residues or impurities inside the water that are often present in case of recently installed plants. Based on the characteristics of the inlet water, you should install suitable water

treatment devices, for residues presence. Please install an inline filter.

The pressure of the cold inlet water should be between 7.2 psi (0.5 bar) and 150 psi (10.34 bar). In case of greater pressure values, please install a pressure reducer upstream from the boiler. Please refer to local jurisdictions on the requirements for cold inlet water pressure.

HEATING CIRCUIT

In order to avoid any scale or deposits on the primary exchanger, the hardness of the heating circuit inlet water should not exceed 14° dh (degrees hardness). However, please check the characteristics of the water used and install suitable treatment devices.

To protect the central heating system from damaging corrosion, flakes or deposits it is important to clean the hydronic system using cleaners such as Fernox F3 Cleaner. For long term protection against corrosion and deposits, the use of inhibitor (such as Fernox F1 inhibitor) is required after cleaning and flushing of the hydronic system. It is important to monitor the concentration of the inhibitor during commissioning and during servicing of unit.



WARNING

Failure to clean the central heating system or add adequate inhibitor invalidates the compliance warranty.

Connect the boiler safety drains (heating circuit safety valve) to a discharge funnel. The manufacturer is not responsible for any floods due to safety valve opening in case of unit excessive pressure build up.



WARNING

In case the boiler is installed as part of a low temperature circuit, please install a safety thermostat on the heating flow, which can stop the boiler activity in case of high heating flow temperature. The company assumes no liability for damage caused to persons or for failure to comply with these instructions.

1.1.11. D.H.W. CIRCULATING LOOP

In order to joint the D.H.W out loop pipe, proceed as follows:

- > unscrew the 1/2" cap A (fig.9);
- > joint the nipple to the D.H.W. circulating pipe.

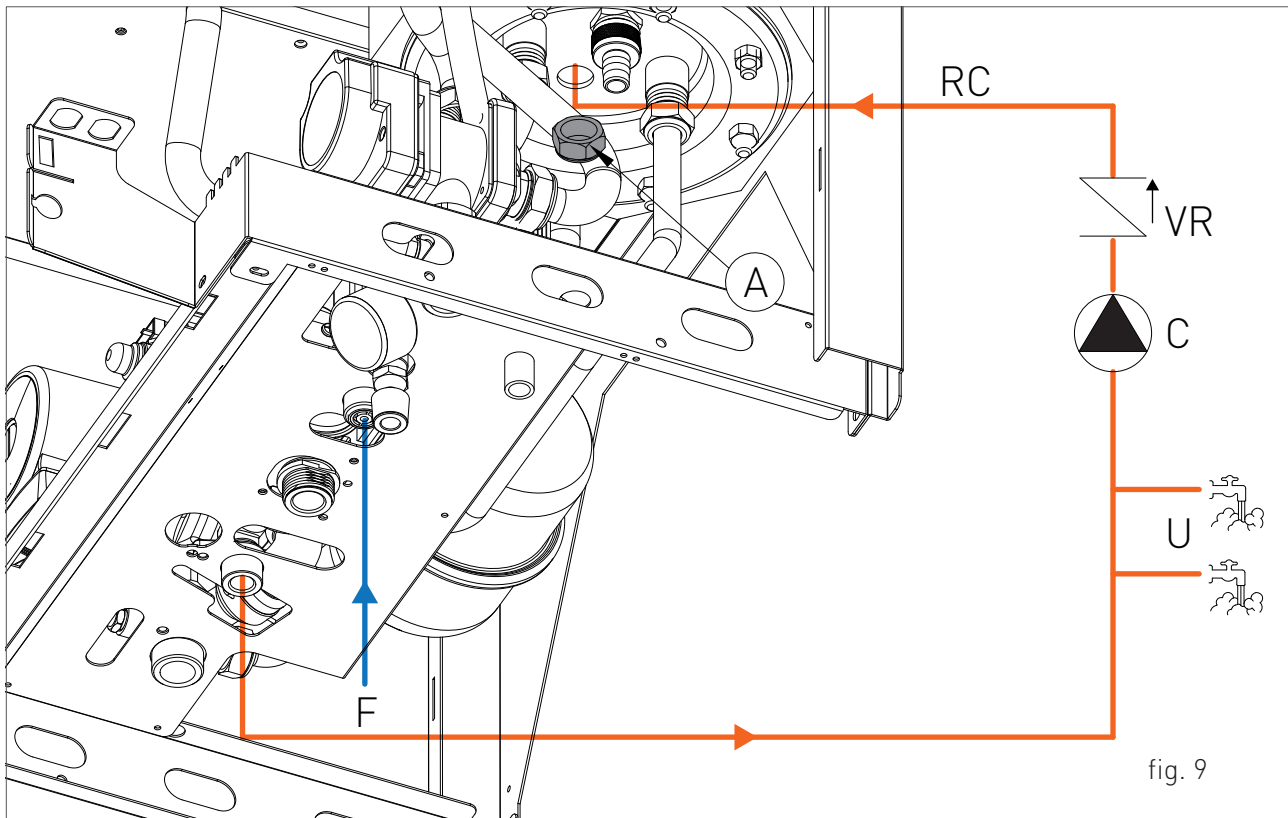

KEY

- RC- D.H.W. RECIRCULATING LOOP
- VR- NON-RETURN VALVE (CHECK VALVE)
- C- CIRCULATOR
- U- FIXTURES
- F- COLD WATER MAINS

1.1.12. SYSTEM FILLING



WARNING

For system filling use only clean tap water.



WARNING

If the system is filled by adding ethylene glycol-type chemical agents it is suggested to install a system fender on the hydronic system in order to separate the heating circuit from the domestic circuit.

Before powering up the boiler, fill the system as follows:

1. Make sure the circulator is not blocked;
2. Slightly loosen the cap of the circulator air eliminator (1-fig. 10) to release the air from the system;
3. Slightly loosen the cap of the air eliminator placed on the top of the condensing block (fig. 12) to release the air from the top of the system;
4. Open the feeding tap "R" (fig. 11);
5. Release all the air;
6. Use pressure gauge "M" (fig. 11) to make sure that the system pressure reaches 1.2 bar (fig. 13);
7. After performing this operation, make sure that the loading tap "R" (fig. 11) is properly closed.

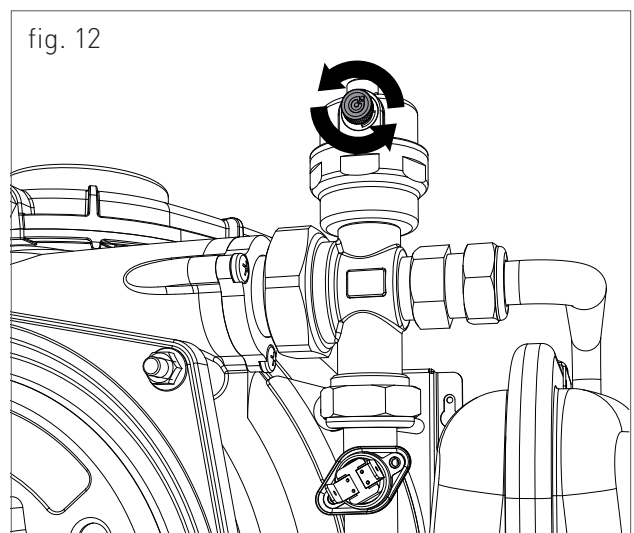
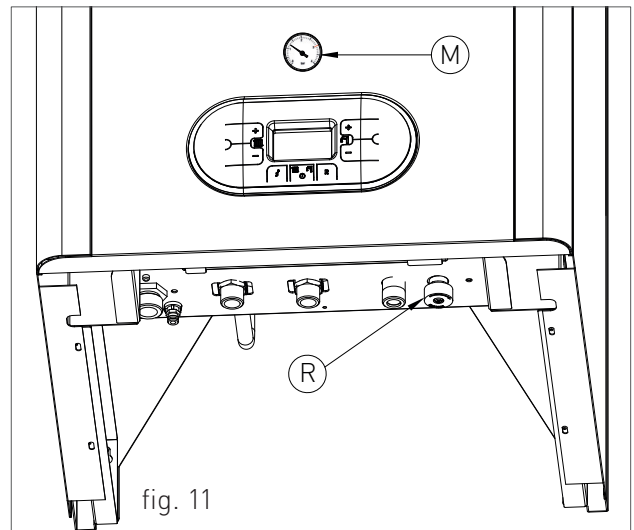
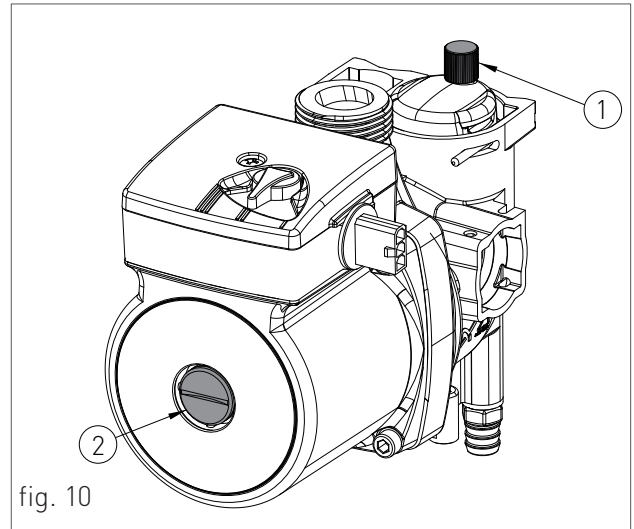

8. Unscrew the circulator cap (2-fig.10) to release any air bubbles and close it to prevent water leakage;
9. Open the air relief valves of the radiators and check the air removal process. When the water starts to leak close the radiators air relief valves.
10. If after performing these operations you observe a decrease of the water pressure inside the system, open once again the loading tap "R" until the pressure gauge indicates the value of 1.2 bar (fig. 13)

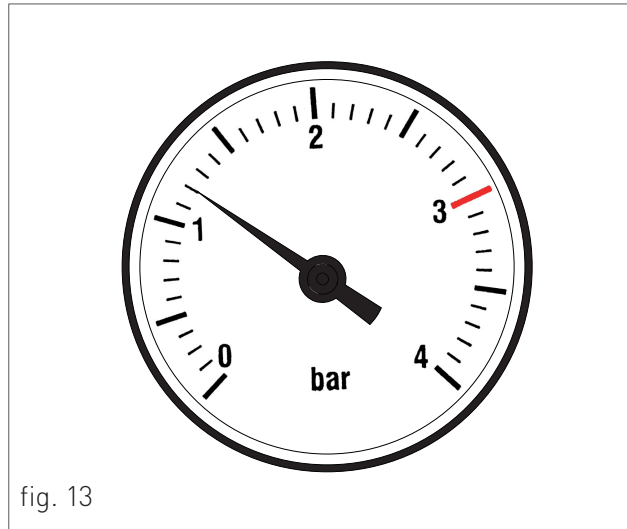

fig. 13

1.1.13. FILLING THE CONDENSATE COLLECTION SIPHON

Before starting the boiler you have to fill the condensate collection siphon in order to avoid flue back up through the siphon.

Fill the condensate collection siphon as follows (see fig. 14):

- › Unscrew the "T" cap from the siphon, fill three quarters of the the siphon with water and screw the "T" cap back in;
- › Connect the dedicated flexible condensate draining tube "P" to a waste disposal system. The condensate can be drained directly in the sewer system by inserting an easily serviceable siphon.

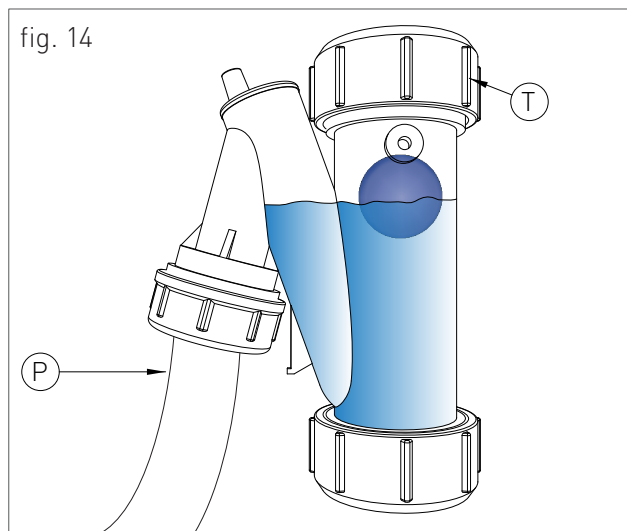

fig. 14



WARNING

After the first months of boiler operation, it is recommended to clean the condensate trap, to eliminate possible deposits coming from the first flow of the condensate inside the boiler technical components. These deposits could cause a malfunctioning of the trap.



1. INSTALLATION

CONDENSATE DRAIN

The boiler produces a significant amount of condensate during operation. This condensation has an acidic pH of 3-5. Follow all local codes and regulations when disposing of condensate from the boiler.

The project engineer should consider the possibility of installing systems to eliminate the acidic condensation, according to system power and buildings' use.

The system should be designed to avoid the condensate freezing. Before the boiler commissioning, check the correct condensate flow.



WARNING

Check before connecting the condensate trap to the drain pipe, for the proper gradient of boiler as described in paragraph "1.1.8 POSITIONING AND MINIMAL TECHNICAL SPACES".



WARNING

Properly connect the siphon condensate from the boiler to a drain system having adequate slope. Where possible, you should make this connection using transparent tubing to check for proper condensate drainage and avoid stagnation that could cause hazardous backflow of the condensate into the boiler.

To connect the condensate drain use only corrosion-resistant material for the drain line.

CONDENSATE NEUTRALIZER KIT

The condensate neutralization system neutralizes the condensate created by the products of combustion.

Acid condensate, introduced into the neutralization box, follows a two-step set course. First phase: nitrates and sulphates filtration through active carbons contained in the first part of the carbon site pipe. In the second phase the pH rises.

The acidity of the condensate can be controlled through the use of appropriate tools for the determination of Ph, such as the litmus paper.

Neutralized condensate can then be routed to the drainage system.

MAINTENANCE

The pH value of the condensate after the neutralizer must be in between **<5,5 – 9,5>**.

Every six months, you need to determine the pH of the condensate treated in the neutralizer. Litmus paper or a digital instrument can be used to measure the pH level.

Neutral point is on the 6,8-7 value; in case of lower value the condensate is acid, in case of a higher value it is basic.

If necessary, replace the active carbon and the reagent granulate.



1.1.14. ANTI-FREEZE PROTECTION

The boiler is protected against freezing using the electronic board design with a function that start the burner and heat the water in the boiler when their water temperature goes below the minimum pre-set values, protecting the boiler up to an external temperature of 14 °F (-10 °C).

The device starts when the hot water temperature goes below 41 °F (5 °C), automatically starting the burner until the water reaches the temperature of 86 °F (30 °C).

The system starts even if display appears "OFF", as long as the boiler is connected to the power (120 V) and gas supply.

For long periods of standby, please empty the boiler and the plant.

If the temperature goes below 14 °F (-10 °C) centigrades, please fill the plant with anti-freeze liquid (CLEANPASS FLUIDO AG cod. 98716LA) and insert and electrical resistances kit (cod. 82259LP).

DILUTION PERCENTAGE OF CLEANPASS FLUIDO AG

ANTIFREEZE - ETHYLENE GLYCOL (%) VOLUME	TEMPERATURE FREEZING POINT °F (°C)
20	18 (-7.5)
30	8.6 (-13)
35	-0.4 (-18)
40	-8.5 (-22.5)
45	-18 (-28)
50	-28 (-33.5)
55	-44 (-42)
60	-58 (-50)

RECOMMENDED MINIMUM PERCENTAGE OF GLYCOL : 20 %



1.1.15. GAS CONNECTION



WARNING

The gas piping must be installed according to all local and state codes, or in absence of local and state codes, with the latest "Natural gas and propane installation code", CAN/CSA-B 149.1 or "National Fuel Gas Code", ANSI Z223.1 (NFPA 54). Consult the "Natural gas and propane installation code" or "National Fuel Gas Code" for the recommended gas pipe size of other materials.

BEFORE PERFORMING THE GAS CONNECTION, MAKE SURE THAT:

- › The gas line size and length meets requested;
- › The gas line is equipped with all safety and control devices required by the standards in force;
- › The internal and external seals of the gas inlet lines of the plant are checked;
- › The device is suitable for use with the type of gas available by checking the boiler data plate (located on the inner side of the front casing. If they do not match you must take the necessary measures to adapt the boiler to another type of gas (see chapter CONVERSION TO A DIFFERENT GAS TYPE);
- › The gas supply pressure falls within the values indicated on the data plate.

1.1.16. ELECTRICAL CONNECTION



DANGER

The equipment is electrically safe only if it is properly connected to an efficient grounding system, performed in compliance with the safety standards in force (National Electrical Code, ANSI/NFPA 70 and or the Canadian Electrical Code Part I, CSA C22.1, Electrical Code). You should check this essential safety requirement. If in doubt, request an accurate check of the electrical system performed by qualified staff, as the manufacturer is not responsible for any damages caused by lack of grounding system.

- › Make sure that the electrical systems is suitable for the maximum power consumed by the equipment, value indicated on the data plate.
- › Make sure that the cables section is appropriate for the maximum power consumed by the equipment.
- › The equipment works with alternating current of 120 V and 60 Hz. The electrical connection must be installed using an all-pole switch with an opening of at least 0.12 in (3 mm) between contacts placed upstream from the device.



WARNING

Make sure that the phase and neutral cables connection is installed in compliance with the wiring diagram (see 1.1.17 POWER SUPPLY).



WARNING

It is strictly forbidden to use adaptors, multiple plugs and/or extensions for the general power supply of the equipment from the electrical supply.



1.1.17. POWER SUPPLY

To power the boiler connect the electrical cables to the terminal inside the control panel as follows:



DANGER

Cut off the voltage from the main switch.

- › remove the boiler's front casing (refer to 2.2.13 ACCESSING THE BOILER).
- › loosen the two screws and remove the plate "A" (see fig. 15).
- › after removing the plate, connect the electrical cables to terminal "B" (see fig. 15):
 - the yellow/green cable to the terminal marked with grounding symbol "⊕".
 - the blue cable to the terminal marked with "N".
 - the brown cable to the terminal marked with "L".

After performing these operations, remount plate "A" and the front casing.

Note: A 3-prong plug is provide with every unit and the above wiring has been performed.

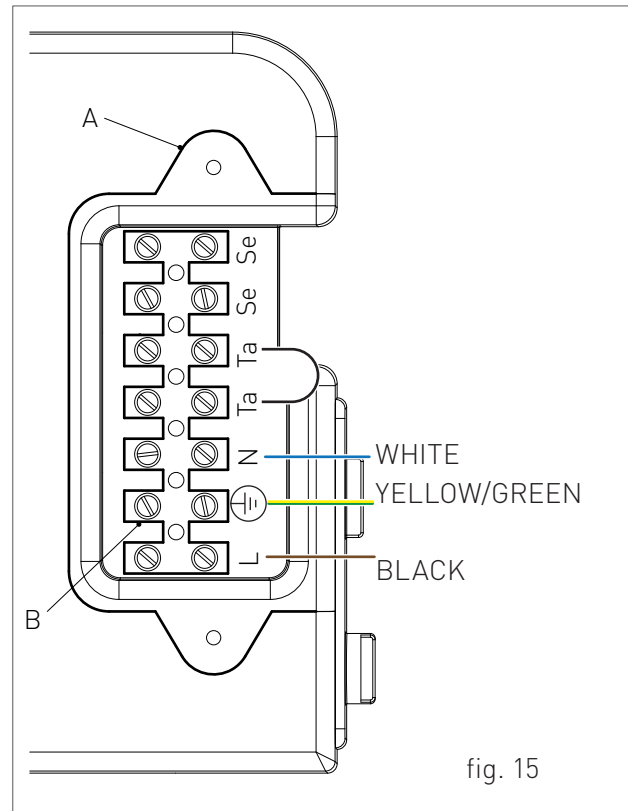

1.1.18. OPTIONAL ELECTRICAL CONNECTIONS

To wire the options below:

- **(SE) EXTERNAL TEMPERATURE PROBE COD. 73518LA**
- **(TA) ENVIRONMENT THERMOSTAT**
- **(CR) REMOTE CONTROL OPEN THERM COD. 40-00017**

use the terminal placed inside the control panel as follows:



DANGER

Shutoff the voltage from the main switch.

- › Remove the front casing of the boiler (see 2.2.13 ACCESSING THE BOILER); unscrew the screws and remove plate "A" (see fig. 16).
- › After removing the plate, connect the electrical cables to terminal "B" (see fig. 16):
 - For the external temperature Probe connect the two non-polarized conductors to the Se-Se contacts.
 - For the environment Thermostat or Remote control, first remove the bridge on the Ta-Ta contacts and then connect the two non-polarized conductors to the Ta-Ta contacts.

After performing these operations, remount plate "A" and the front casing.

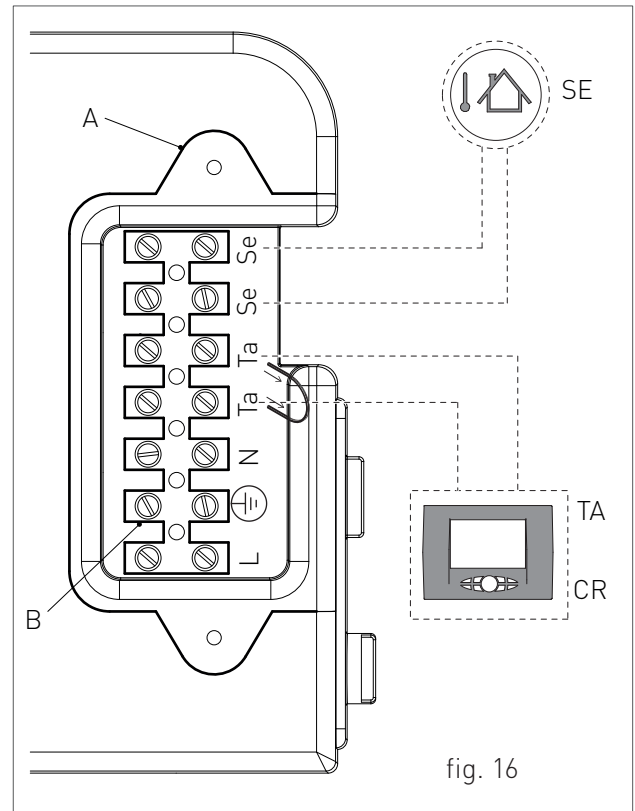

NB: In case of simultaneous presence of external probe and remote control, the modulation board only sends the external temperature value to the remote device without using it for modulation.

The communication between board and remote control takes place independently from the boiler's operating mode and after establishing the connection, the used interface on the board is disabled and the display shows the symbol .

To wire the options below:



DANGER

Shutoff the voltage from the main switch.

- (PM) MODULATING PUMP
- (TP) DOMESTIC HOT WATER PRE-HEATING DEACTIVATION TIMER
- (CT) TELEPHONE DIALER
- BUS 0-10V
- (SVZ) CONTROL BOARD FOR AREA VALVES CONNECTED TO A REMOTE CONTROL COD. 65-00030

- > Remove the boiler's front casing (refer to 2.2.13 ACCESSING THE BOILER).
- > Remove the crankcase of the control panel (see 2.2.14 ACCESSING THE ELECTRONIC BOARD).
- > After removing the crankcase, connect the items below to the electronic board (see fig. 17):

After performing these operations, remount the crankcase and the front casing.

Use the electronic board placed inside the control panel as follows:

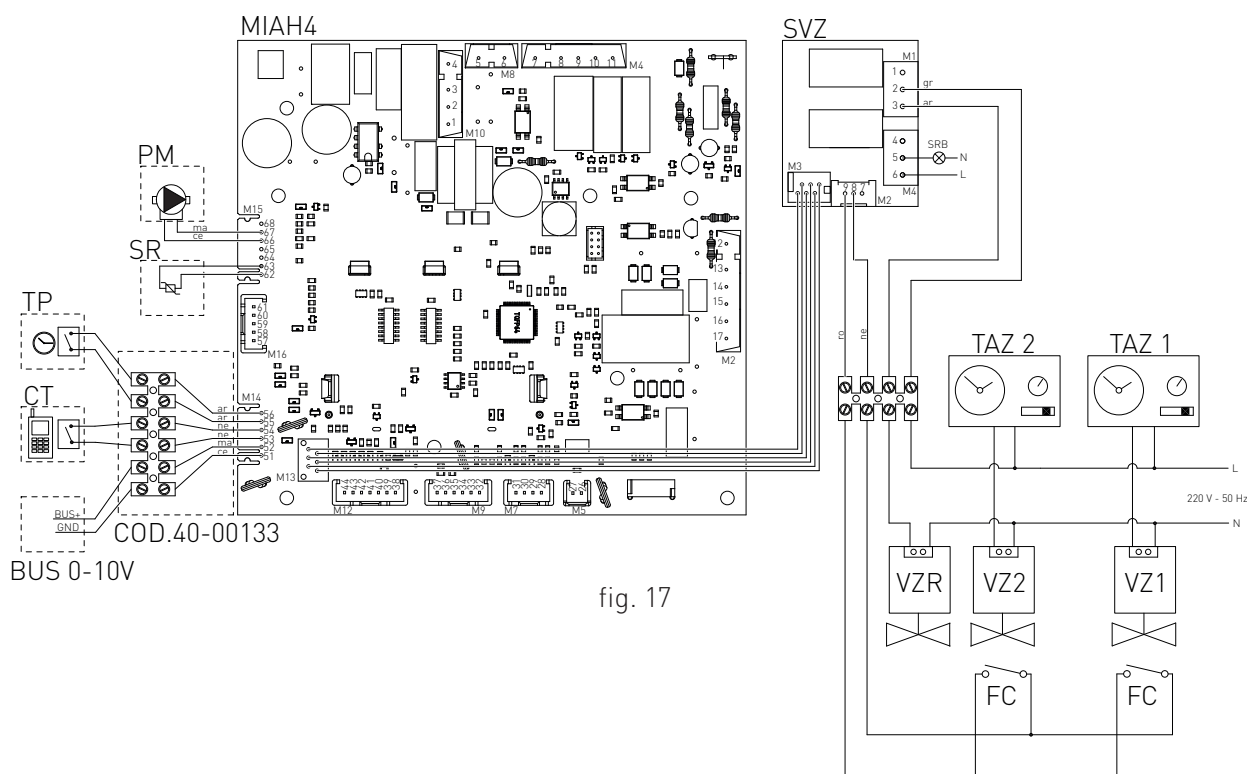

fig. 17

SR:	RETURN PROBE	FC:	AREA VALVES LIMIT SWITCH
SRB:	REMOTE LED FOR SIGNALLING BOILER LOCKOUT	GY:	GREY
TAZ1:	ENVIRONMENT THERMOSTAT AREA 1	O:	ORANGE
TAZ 2:	ENVIRONMENT THERMOSTAT AREA 2	BK:	BLACK
VZ1:	AREA 1 VALVE	BR:	BROWN
VZ2:	AREA 2 VALVE	BL:	LIGHT BLUE
VZR:	REMOTE CONTROLLED AREA VALVE	R:	RED



1. INSTALLATION

1.1.19. VENTING



WARNING

In order to ensure proper operation and efficiency of the device you have to connect the boiler fume exhaust fitting to the exhaust and fresh air adapters (loosely supplied in boiler). It is recommended to install discharge systems approved by Radiant.



WARNING

All termination kits must be located and installed in accordance with local building code and CSA B149.1 Natural Gas and Propane Installation Code.



WARNING

For condensate collection please follow the local codes.

- › All exhaust runs shall be sloped such that any condensate would move towards the combustion chamber so that it can be collected and drained via the internal condensate trap of the appliance (Refer to section 1.1.18).
- › All combustion air intake runs where possible should be sloped in a manner to avoid rain water, dust or foreign objects from entering the appliance (Refer to section 1.1.18).
- › In case of horizontal polypropylene co-axial system installation, properly orientate the horizontal co-axial terminal in relation to the slopes inside the exhaust pipe and to protect the combustion air pipe from adverse weather conditions (Refer to section 1.1.18, sub-section III (a) and figure 20).

This appliance is certified to be installed using polypropylene, PVC and CPVC. For Canada use System 636 polypropylene, PVC and CPVC Type BH Gas Venting Systems certified to ULC S636. Types of venting configurations for this appliance are, co-axial vent (pipe with in a pipe), co-linear vent (separate pipes for exhaust and combustion

air), and single exhaust vent (uses room air for combustion).

This appliance shall not be connected to a chimney flue serving a separate appliance, designed to burn solid fuel.

Use of cellular core PVC (ASTM F891), cellular core CPVC, or Radel® (polyphenylsulfone) in non-metallic venting systems is prohibited.

The vent for this appliance shall not terminate:

- 1) over public walkways; or
- 2) near soffit vents or crawl space vents or other areas where condensate or vapor could create a nuisance or hazard or cause property damage; or
- 3) where condensate vapor could cause damage or could be detrimental to the operation of regulators, relief valves, or other equipment.

Please refer to figure 14 for further clearances on where to terminate the vent.

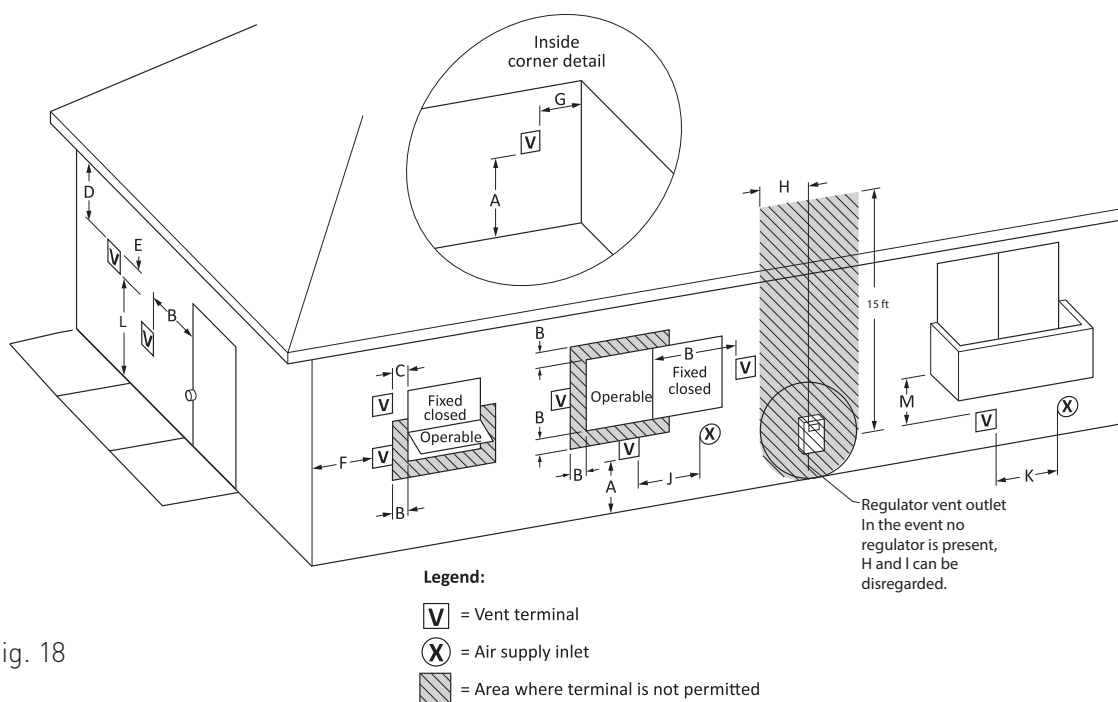

fig. 18

	Canadian installations ¹ .	US installations ² .
A = Clearance above grade, veranda, porch, deck, or balcony	12 in (30 cm)	12 in (30 cm)
B = Clearance to window or door that may be opened	12" (30 cm) Inputs up to and including 100,000 BTU (30kW) 36" (91 cm) Inputs greater than 100,000 BTU (>30kW)	Non direct vent: 4 ft (1.2 m) below or to side of opening; 1 ft (300 mm) above opening Direct vent: 12 in (30 cm)
C = Clearance to permanently closed window	Zero clearance to permanently closed window. Please consult with local installation codes, the requirements of the local gas supplier and local regulator having jurisdiction for further requirements.	
D = Vertical clearance to ventilated soffit located above the terminal within a horizontal distance of 2 ft (61 cm) from the center line of the terminal.	12 in (30 cm)	12 in (30 cm)



1. INSTALLATION

	Canadian installations ¹ .	US installations ² .
E = Clearance to unventilated soffit	12 in (30 cm)	12 in (30 cm)
F = Clearance to outside corner	Zero Clearance	Zero Clearance
G = Clearance to inside corner	In accordance with the local installation codes and the requirements of the local gas supplier.	
H = Clearance to each side of center line extended above meter/regulator assembly	3 ft (91 cm) within a height 15 ft (4.6 m)	In accordance with the local installation codes and the requirements of the local gas supplier.
I = Clearance to service regulator vent outlet	3 ft (91 cm)	In accordance with the local installation codes and the requirements of the local gas supplier.
J = Clearance to nonmechanical air supply inlet to building or the combustion air inlet to any other appliance	12" (30 cm) Inputs up to and including 100,000 BTU (30kW) 36" (91 cm) Inputs greater than 100,000 BTU (>30kW)	Non direct vent: 4 ft (1.2 m) below or to side of opening; 1 ft (300 mm) above opening Direct vent: 12 in (30 cm)
K = Clearance to a mechanical air supply inlet	6 ft (1.83 m)	3 ft (91 cm) above if within 10 ft (3 m) horizontally
L = Clearance above paved sidewalk or paved driveway located on public property	7 ft (2.13 m)†	7 ft (2.13 m) †
M = Clearance under veranda, porch deck, or balcony	12 in (30 cm)‡	12 in (30 cm)‡

NOTE:

1. In accordance with the current CAN/CGA-B149 Installation Codes.

2. In accordance with the current ANSI Z223.1-(Latest Edition)/NFPA 54 National Fuel Gas Code.

† A vent shall not terminate directly above a sidewalk or paved driveway that is located between two single family dwellings and serves both dwellings.

‡ Permitted only if veranda, porch, deck, or balcony is fully open on a minimum of two sides beneath the floor.



1.1.20. TYPES OF EXHAUST SYSTEMS

GENERAL INTRODUCTION

The venting installation must conform to the requirements of the authority having jurisdiction or, in the absence of such requirements, to the National Fuel Gas Code, ANSI Z223.1/NFPA 54, and/or Natural Gas and Propane Installation Code, CAN/CSA B149.1.

Horizontal exhaust runs shall slope upwards not less than 1/8 in/ft [10.5 mm/m] from the boiler to the vent terminal although 1/4 in/ft [21 mm/m] is preferred. Venting shall be installed so as to prevent the accumulation of condensate throughout the vent run. Provide means for drainage of condensate on all vertical exhaust runs and where necessary.

Horizontal combustion air intake runs should slope downwards not less than 1/4 in/ft [21 mm/m] from the boiler to the air intake terminal where possible.

For installations in which the combustion air run cannot slope to the outdoors, it is recommended that a trap be installed closed to the appliance (see figure 'H').

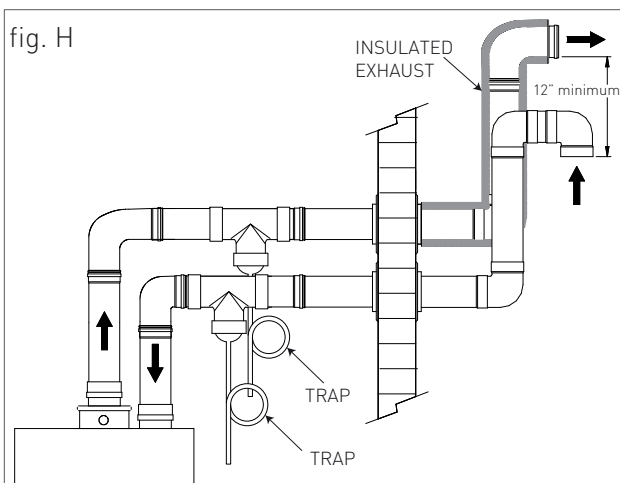

Where not possible a water trap shall be installed so as to collect moisture or water from entering into the air box of the water heater. Provide means for drainage of moisture and water on all vertical air intake runs and where necessary.

Traps, if used, should have pipe slopes not less than 1/4 in/ft [21 mm/m] downwards to the trap.

The use of thermal insulation shall be prohibited on non-metallic vent pipe and fittings in conditioned space. However, for vent runs in unconditioned space where freezing is a concern, a minimum of 1/2" thick Armaflex is recommended.

I - CO-LINEAR VENT (FRESH AIR AND EXHAUST)

The Gas-Fired wall mounted hot boilers can be installed with two separate pipes. The two separate pipes consists of one for the exhaust an the other for combustion air intake.

Please refer to Table 1: Allowable vent lengths for maximum vent and combustion air intake runs.

Co-linear vent installations can be either be installed through the wall or through the roof.

I (a) - THROUGH THE WALL LNSTALLATION:

Through the wall installations can terminate with two separate pipes or with a concentric terminal.

Please refer to figure 'A' for installations using terminations using co-linear vent.

Refer to figures 'B' and 'C' for installations using co-linear vent with co-axial terminal.

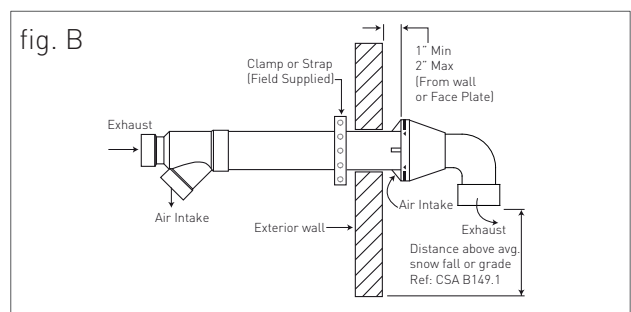
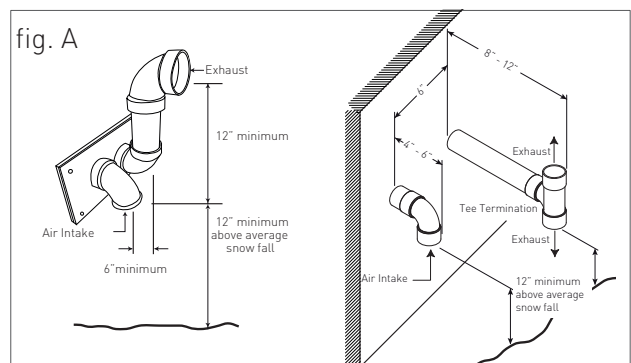



1. INSTALLATION

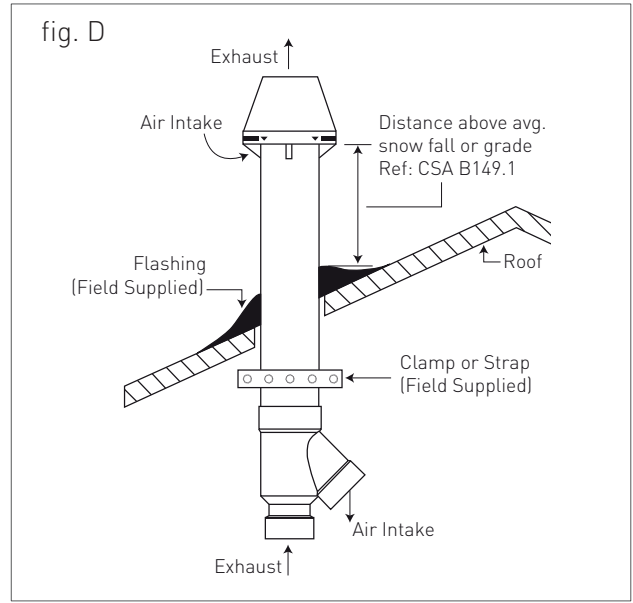
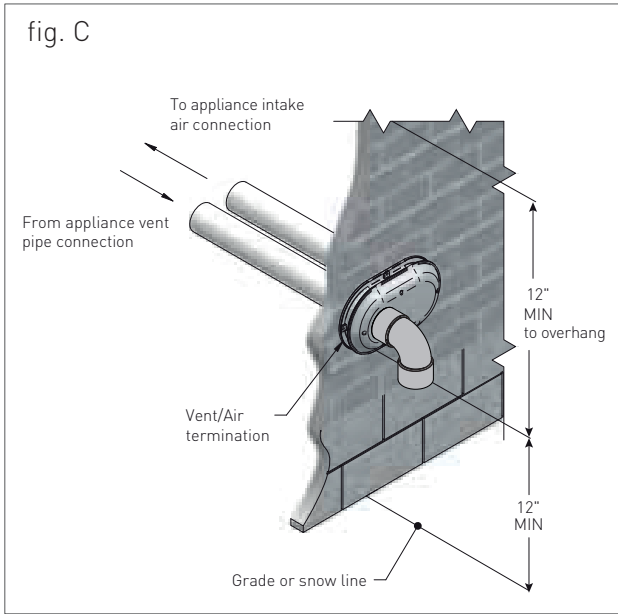

IPEX Low Profile Termination Kits (PVC)*(fig. C)

Size	IPEX	Product Code
2"		19698RAD
3"		196985RAD
4"		196986RAD

*Kits must be purchased via Radiant North America for proper kit.



I (b) - THROUGH THE ROOF LNSTALLATION:

Through the roof installations can terminate with two separate pipes or with a co-axial terminal.

Refer to figure 'D' for installations using a co-linear vent with vertical co-axial terminal.

II - SINGLE VENT

This gas-fired wall mounted hot boilers can be installed with one single vent pipe for exhaust.

Please refer to Table 1: Allowable vent lengths for maximum vent run.

Single vent installations can be either be installed through the wall or through the roof.





II (a) - THROUGH THE WALL INSTALLATION:

Please refer to figure 'E' for through the wall single vent installations.

II (b) - THROUGH THE ROOF INSTALLATION:

Please refer to figure 'F' for through the roof single vent installations.

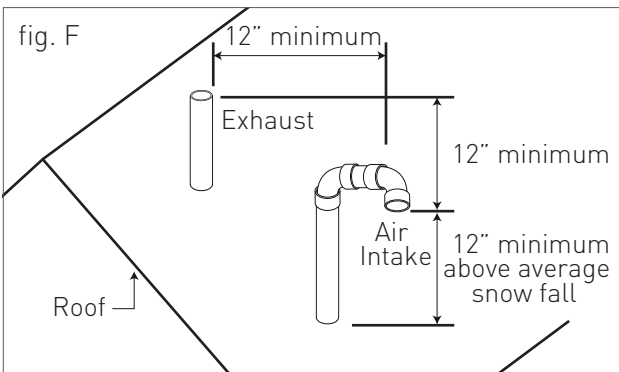
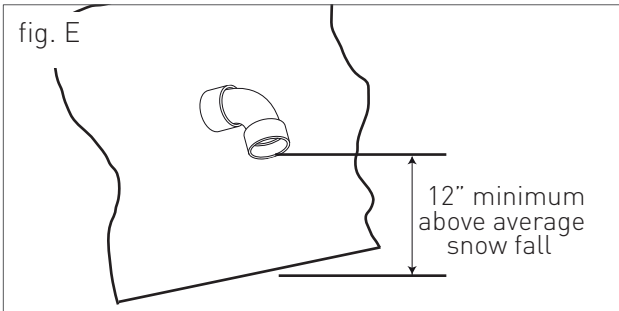



1. INSTALLATION

AIR INTAKE / FLUE EXHAUST Ø 3" (80 MM) ADAPTORS WITH PP TEST POINT (COD.: 65-00433)

These adaptors are to be installed on co-linear vent (two separate pipes for exhaust and combustion air), and single exhaust vent (using room air for combustion). Additional bushings or couplings are required to transition from 3" schedule 40 pipe to 2" or 4" schedule 40 pipe only for installations using 2" or 4" schedule 40 pipe. Additional transition adaptors are not needed for installations using only 60 mm or 80 mm polypropylene, or 3" schedule 40 PVC or CPVC pipe.

Ensure that the adaptors are installed correctly into the correct locations as per the attached figure 19.

Installation instructions:

- Remove the air intake cover plate.
- Clean the inspection collar surface and the area of the air intake hole.
- Stick the appropriate neoprene gaskets onto the underside of the mounting flange of the adaptors. Pay attention to aligning the four mounting through holes.
- Mount the intake/flue exhaust adaptors with self tapping screws provided with the flue kit.
- Install the first piece of 60mm or 80mm polypropylene, 3" schedule 40 PVC or CPVC pipe, or 3" X 2" schedule 40 PVC or CPVC bushing until it bottoms out.
- Finally use the gear clamp to tighten the first piece of either 3" or 2" pipe to the adapter.

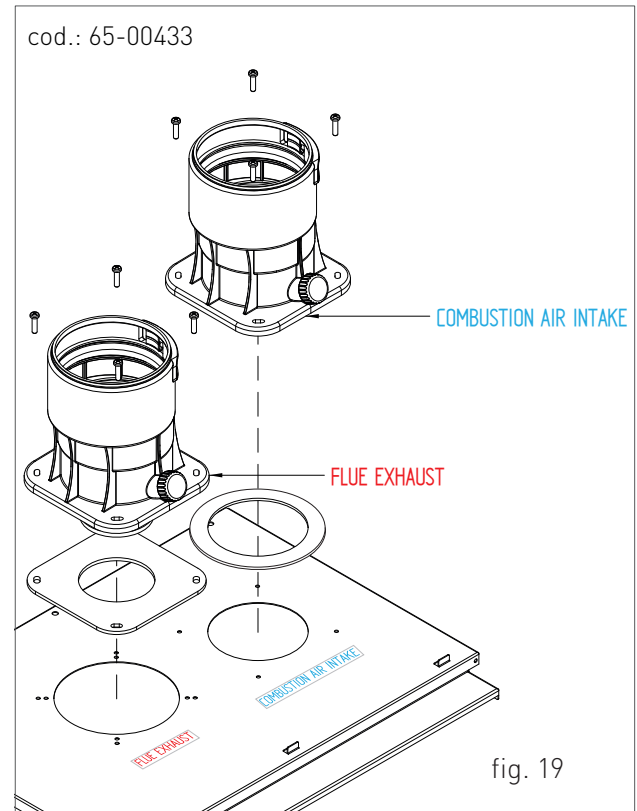

fig. 19



III (a) - KIT M&G HORIZONTAL CO-AXIAL SYSTEM, INTERNAL POLYPROPYLENE DUCT ADJUSTABLE AT 360°.

It allows exhaust and air intake from external wall.

Suitable only for condensing unit.

It allows exhaust and air intake for combustion through co-axial ducts, the external one for air intake, the plastic internal one for exhaust.

PLEASE SEE THE MAXIMUM EXHAUST LENGTH IN THE TABLE IN 1.1.21 "ALLOWABLE VENT LENGTHS".

The maximum exhaust length (or linear reference length) can be calculated by summing the length of the linear tube.

When terminating horizontally, install an elbow at the end of the terminal. For area where snow is a concern it is recommended to point the elbow downwards.

M&G PolyPro Concentric Kits*

Size	Horizontal Product Code
Ø 2.3/3.9 in (Ø 60/100 mm)	2PPC-HKRAD (fig. 20)
Ø 3.1/4.9 in (Ø 80/125 mm)	3PPC-HKRAD (fig. 21)

*Kits must be purchased via Radiant North America for proper kit.

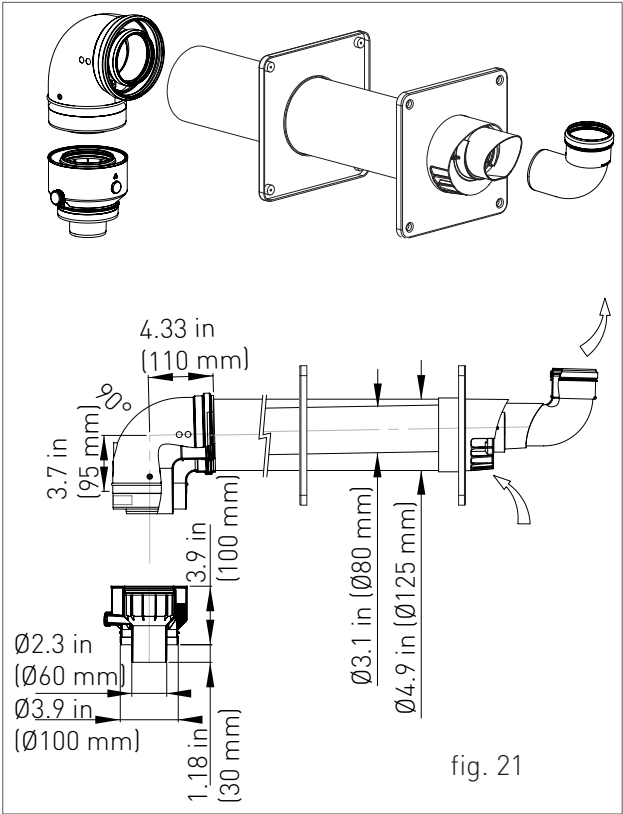
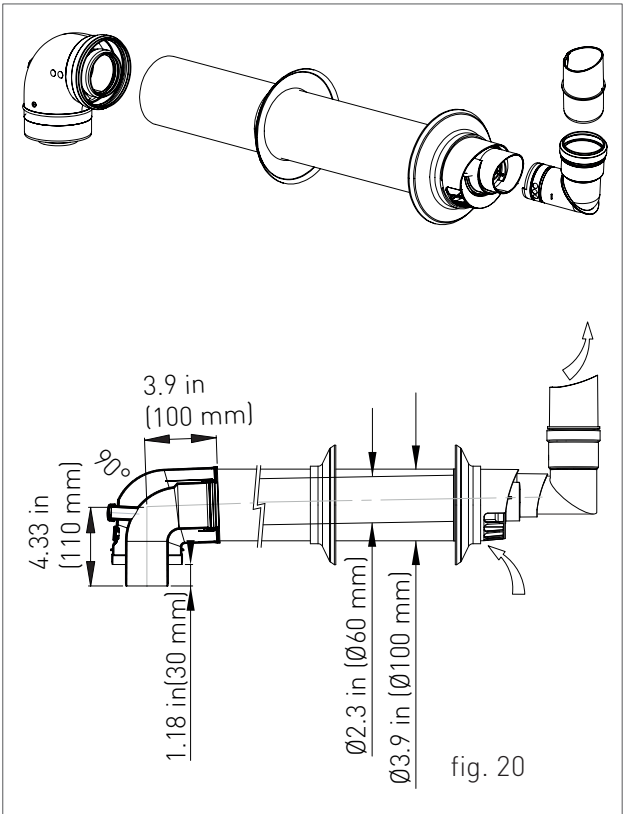



1. INSTALLATION

1.1.21. TABLE 1: ALLOWABLE VENT LENGTHS

Vent Configuration	Pipe Size	Minimum Length Vertical and Horizontal for Vent Run	Max Equivalent length Vertical and Horizontal for vent run	Gas Type	Exhaust Vent	Intake Vent
Co-axial vent	Ø2.3/3.9" (Ø60/100 mm)	1 ft (0.3 m) + elbow	32 ft (10 m) + elbow*	Natural or Propane	Polypropylene	Polypropylene
Co-linear vent (2 Separate pipes)****	2" (60 mm)	3.3 ft (1 m)	65 ft (20 m)**	Natural or Propane	PVC, CPVC, Polypropylene	PVC, CPVC, Polypropylene, ABS
Co-linear vent (2 Separate pipes)****	3" (80 mm)	3.3 ft (1 m)	150 ft (46 m)	Natural or Propane	PVC, CPVC, Polypropylene	PVC, CPVC, Polypropylene, ABS
Single vent	2" (60 mm)	1.6 ft (0.5 m)	36 ft (11 m)***	Natural or Propane	PVC, CPVC, Polypropylene	PVC, CPVC, Polypropylene, ABS
Single vent	3" (80 mm)	1.6 ft (0.5 m)	100 ft (30 m)	Natural or Propane	PVC, CPVC, Polypropylene	PVC, CPVC, Polypropylene, ABS

* The domestic fan maximum speed adjustment (P11) must be changed to a value of 198 Hz and the heating fan maximum speed adjustment (P13) must be changed to a value of 183 Hz with a total vent run of above 10 ft (3 m).

** The domestic fan maximum speed adjustment (P11) must be changed to a value of 198 Hz and the heating fan maximum speed adjustment (P13) must be changed to a value of 183 Hz with a total vent run of above 22 ft (7 m).

*** The domestic fan maximum speed adjustment (P11) must be changed to a value of 198 Hz and the heating fan maximum speed adjustment (P13) must be changed to a value of 183 Hz with a total vent run of above 19 ft (6 m).

**** Vent run consists of allowable vent length for exhaust pipe and an additional allowable vent length for combustible air.

NOTE: In Canada, exhaust vent must be approved to ULC S636 standard.

EQUIVALENT LENGTHS

Each 2"/3" (60 mm / 80 mm) 45° elbow equates to 2.5 linear feet to vent pipe.

Each 2"/3" (60 mm / 80 mm) 90° short radius elbow equates to 7.5 linear feet to vent pipe.

Each 2"/3" (60 mm / 80 mm) 90° long radius elbow equates to 5 linear feet to vent pipe.

Each Ø2.3/3.9" (Ø60/100 mm) co-axial 90° short radius elbow equates to 5 linear feet to vent pipe.

The total maximum equivalent vent pipe distance cannot exceed the maximum length listed for horizontal and vertical venting distance. The maximum lengths are not including elbows unless otherwise stated. Exceeding the maximum venting distances will cause the appliance to malfunction or cause an unsafe condition.



Co-axial Termination (PVC/CPVC ULC S636)*

Size		IPEX Product Code		Royal Plastics Product Code	
Diameter	Length	PVC	CPVC	PVC	CPVC
2" (60 mm)	16 ft (4.8 m)	196005	197040	52CVKGV6502	
	28 ft (8.5 m)	196105	197033	52CVKGV6502-28	
	40 ft (12.1 m)	196125		52CVKGV6502-40	
3" (80 mm)	20 ft (6 m)	196006	197009	52CVKGV6503	52CVKGVSF9003
	32 ft (9.7 m)	196106	197107	52CVKGV6503-32	52CVKGVSF9003-32
	44 ft (13.4 m)	196116	197117	52CVKGV6503-44	52CVKGVSF9003-44
4" (100 mm)	36 ft (10.9 m)	196021	197021	52CVKGV6504	52CVKGVSF9004-36

*Kits must be purchased via Radiant North America for proper kit.



1. INSTALLATION

Polypropylene venting listed to ULC-S636

Diameter	Length	Brand	Part Number	Description
3/5" (80/125mm)		Z-Dens	2ZDACLC3335	Adaptor Collinear to Concentric
3" (80mm)	12" (305mm)	Z-Dens	2ZDP312	Single Wall Pipe
	24" (305mm)	Z-Dens	2ZDP324	Single Wall Pipe
	36" (305mm)	Z-Dens	2ZDP336	Single Wall Pipe
	72" (305mm)	Z-Dens	2ZDP372	Single Wall Pipe
		Z-Dens	2ZDE345	Single Wall 45° Elbow
		Z-Dens	2ZDE387	Single Wall 87° Elbow
		Z-Dens	3PPS-CDC	Single Wall Condensate Drain
		Z-Dens	3PPS-TCDC	Single Wall Tee w/ Drain Cap
3" (80mm)	12" (305mm)	PolyPro	3PPS-12C	Single Wall Pipe
	36" (305mm)	PolyPro	3PPS-36C	Single Wall Pipe
	72" (305mm)	PolyPro	3PPS-72C	Single Wall Pipe
		PolyPro	3PPS-E45C	Single Wall 45° Elbow
		PolyPro	3PPS-E90C	Single Wall 90° Elbow
		PolyPro	3PPS-CDC	Single Wall Condensate Drain
		PolyPro	3PPS-TCDC	Single Wall Tee w/ Drain Cap



2. SUPPORT CENTRE SECTION

All operations described below relative to first start-up, maintenance and replacement and should be performed only by qualified service technician.



2.1. FIRST START-UP

2.1.1. PRELIMINARY OPERATIONS FOR FIRST START-UP

The first start-up operations consist of checking the correct installation, adjustment and operation of the device. Proceed as follows:

- › Make sure all water lines connected to the boiler have been thoroughly flushed prior to first used. It is critical that all installation/ construction debris has been removed from the system before firing the boiler for the first time.
- › Check the inner components and ensure that they are sealed in accordance with the specifications provided and by standard and regulations.
- › Check if the gas used is suitable for the boiler;
- › Check if the gas capacity and relative pressures comply with those on the rating plate;
- › Check the operation of the safety device in case of lack of gas;
- › Make sure that the device supply voltage corresponds with that on the plate (120 V – 60 Hz) and that the wiring is correct;
- › Make sure that the grounding system works properly;
- › Make sure that the combustion air circulation, exhaust and condensate discharge take place properly in compliance with the Local and National Laws and Standards in force;
- › Make sure that the venting and their connections and comply with the requirements of the Local and National Laws and Standards;
- › Make sure that the heating system valves are open;
- › Make sure that there is no intake of gaseous products within the system;
- › Make sure that there are no flammable liquids or materials near the device;
- › Open the boiler gas valve and make sure that there are no gas leaks upstream from the device (the burner gas connection must be checked while the unit is running);
- › In case of new installation of the gas supply network, the air inside the gas line may lockout the device at first start-up. Repeat the start-up procedure to purge all the air inside the gas line.



2.1.2. BOILER COMMISSIONING



WARNING



Make sure that the system is correctly filled.

Proceed with boiler commissioning as follows:

- › Power the boiler.

THE START-UP SYSTEM WILL AUTOMATICALLY ACTIVATE THE SYSTEM AIR RELIEF CYCLE FUNCTION DISPLAYED ON SCREEN WITH CODE "F33" (ONLY AT FIRST START-UP WILL LAST FOR 5 MINUTES). When function "F33" is active, the pump is enabled and the burner start-up request is disabled. The boiler can work normally only after completing the operation.

NOTE: Only at the first start-up the system relief cycle performed by the boiler lasts 5 minutes. After each water pressure reset the boiler will automatically perform a reduced system relief cycle, of 2 minutes. Throughout this function the display will show the code "F33". The boiler can work normally only after completing the operation.

- › Open the gas valve.
- › Use the button  to select the desired operation mode. If the symbol is displayed fixed, it means that the function was activated.
- › The burner will start as soon as the thermostat contact is closed;
- › If the flame is not sensed, the board will repeat the start-up operations after post-ventilation (20 seconds).
- › You might have to repeat the start-up operation several times to release all air inside the gas lines. Before repeating the operation, wait at least 5 seconds from the last start-up attempt and unlock the boiler from "E01" error code by pressing the Reset  key.

2.1.3. CO₂ VALUE CHECK AND CALIBRATION



WARNING

The CO₂ value should be measured with the casing assembled, while the gas valve could only be adjusted with the casing open.

To check and calibrate the CO₂ value to minimum and maximum heating power proceed as follows:

FOR MINIMUM HEATING POWER

- › Enable chimney-sweep function holding the key **Ⓡ** for 7 seconds (maximum operating time is 15 minutes), then press key **⊖** of the heating circuit  to set minimum power for heating function, the display will show 'Lo'.
- › Insert the combustion analyser probe in the provided exhaust tap 'PF' (fig. 22), then make sure that the CO₂ value complies with the requirements indicated in 2.2.8 "Technical data", otherwise adjust using screw 'A' (fig. 23) and adjust using a 4 Allen wrench the screw '2' (fig. 23) of the Off-Set adjuster. To increase the CO₂ value, turn the screw clockwise and counter-clockwise if you want to decrease it.
- › Once completed the adjustment, tighten the protection screw 'A' (fig. 23) on the Off-Set adjuster.

FOR MAXIMUM HEATING POWER

- › Press key **⊕** of the heating circuit  to set maximum power for heating function, the display will show 'HI'.
- › Make sure that the CO₂ value complies with the indications in 2.2.8 "Technical data", otherwise adjust using screw '1' (fig. 23) of the gas flow adjuster. To increase the CO₂ value, turn the screw counter-clockwise and clockwise if you want to decrease it.

- › After each adjustment variation on screw '1' (fig. 23) of the gas flow adjuster you have to wait for the boiler to stabilize itself to the set value (about 30 seconds).
- › Then press key **⊖** of the heating circuit  to set minimum power for heating function and check that CO₂ value hasn't changed, in case it has changed, please repeat the setting as described previously.
- › Press the button **⏏** to deactivate the chimney sweep function.

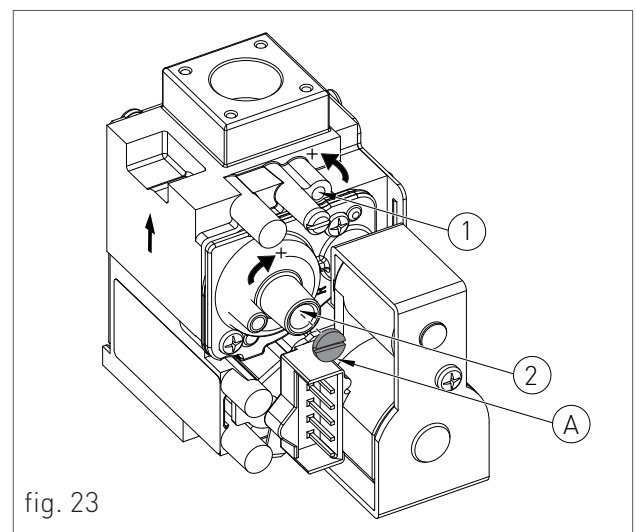
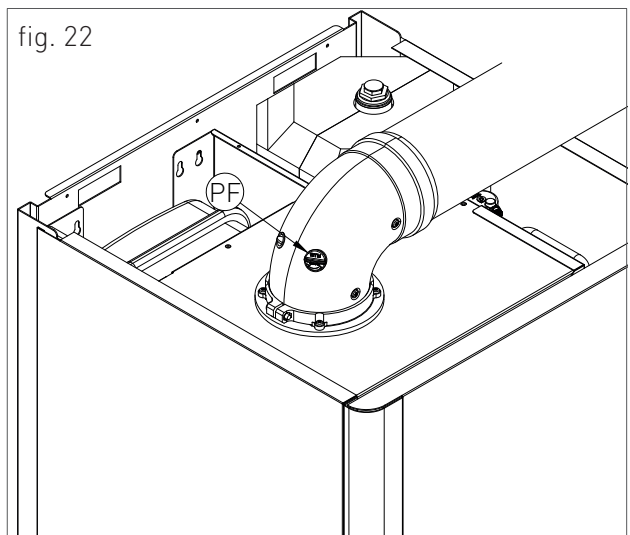

2.1.4. ACCESSING AND PROGRAMMING THE PARAMETERS

To access the parameters menu and adjust their values, follow the procedure below:

1. Press the button  to select the OFF mode displayed using the symbol .

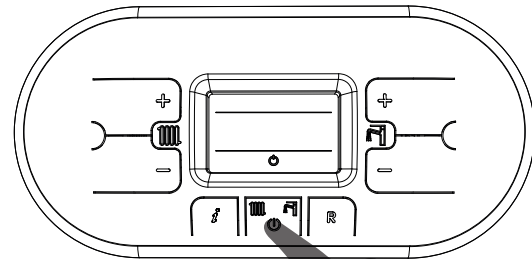







fig. 24

2. Hold at the same time the keys  and  until on the display appears the symbol  with the message 'P00', and release the keys  and .

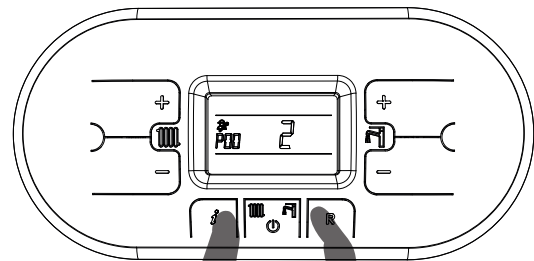

fig. 25

3. Use the keys  and  of the heating circuit  to select the parameter to be edited.

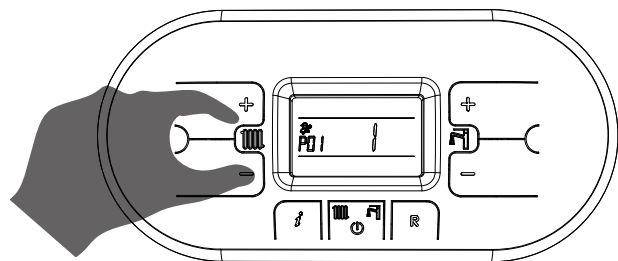

fig. 26

4. Use the keys '+' and '-' of the domestic circuit  to change the value of the parameter.

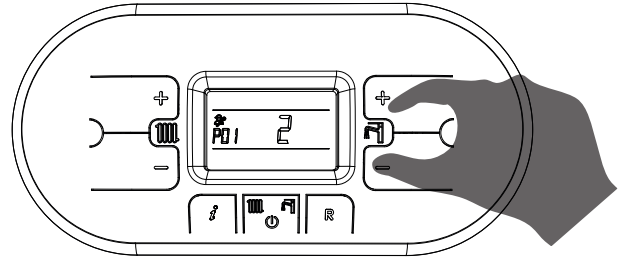



fig. 27

5. Press the key  to confirm the action and wait for the display to stop blinking, indicating the adjustment was implemented.

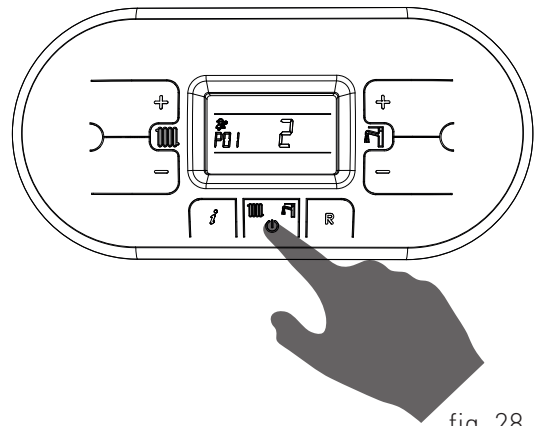



fig. 28

6. To exit the parameters menu, hold at the same time the keys 'i' and 'R' and wait for the symbol  to appear on the display.

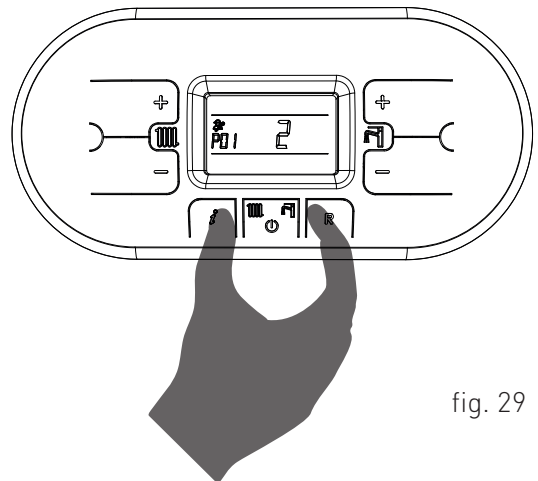

fig. 29



2.1.5. DIGITECH CS (MIAH402) PARAMETERS TABLE

PARAMETER	DESCRIPTION	RANGE	FUNCTION
P00	BOILER MODEL SELECTION	0 - 10	0 - 7 = N.A. 8 = R2K 24 - R2KA 24/8 9 = R2K34 - R2KA 34/20 - R1K 34/B 10 = R1K 55-R2K 55
P01	BOILER TYPE SELECTION	0 - 5	0 = INSTANTANEOUS → R2K 1 = N.A. 2 = ACCUMULATION (STORAGE) → R1K /B - R2KA 3 = ACCUMULATION (STORAGE) COMFORT → R1K /B - R2KA 4 = INSTANTANEOUS COMFORT - FAST H2O → R2K 5 = HEATING ONLY → R1K 55
P02	GAS TYPE SELECTION ATTENTION: READ THE INSTRUCTION IN 2.2.19 'CONVERSION TO A DIFFERENT GAS TYPE' BEFORE CHANGING THIS PARAMETER.	0 - 1	0 = NATURAL GAS (AND SETS FAN SPEED SETTING AT PARAMETERS P10 - P11 - P12 - P13) 1 = PROPANE (AND SETS FAN SPEED SETTING AT PARAMETERS P10 - P11 - P12 - P13)
P03	SETTING THE HEATING TEMPERATURE IN CASE THE BOILER IS INSTALLED AS PART OF A LOW TEMPERATURE CIRCUIT, PLEASE INSTALL A SAFETY THERMOSTAT ON THE HEATING FLOW, WHICH CAN STOP THE BOILER ACTIVITY IN CASE OF HIGH HEATING FLOW TEMPERATURE. THE COMPANY ASSUMES NO LIABILITY FOR DAMAGE CAUSED TO PERSONS OR FOR FAILURE TO COMPLY WITH THESE INSTRUCTIONS.	0 - 1	0 = STANDARD 86-167 °F (30-75 °C) (SET BY DEFAULT) 1 = REDUCED 77-113 °F (25-45 °C) FOR FLOOR SYSTEMS



2. FIRST START-UP

PARAMETER	DESCRIPTION	RANGE	FUNCTION
P04	<p>HEATING RUN-UP</p> <p>THROUGH THIS PARAMETER YOU CAN SET THE TIME, DURING START-UP PHASE, NECESSARY FOR THE BOILER TO REACH THE MAXIMUM SET POWER (ON THE HEATING SIDE).</p>	0 - 4	<p>0 = (DISABLED)</p> <hr/> <p>1 = 50 SECONDS (SET BY DEFAULT)</p> <hr/> <p>2 = 100 SECONDS</p> <hr/> <p>3 = 200 SECONDS</p> <hr/> <p>4 = 400 SECONDS</p>
P05	<p>ANTI-WATER HAMMER SELECTION</p> <p>ONCE THIS FUNCTION IS ENABLED, THE DHW CONTACT WILL BE DELAYED FOR A TIME EQUAL TO THE SET VALUE.</p>	0 - 20	<p>0 = DISABLED</p> <hr/> <p>1 - 20 = THE VALUE IS EXPRESSED IN SECONDS</p>
P06	<p>DOMESTIC CIRCUIT PRESERVATION FUNCTION (ONLY FOR INSTANTANEOUS BOILER)</p> <p>THROUGH THIS PARAMETER YOU CAN PRESERVE THE CIRCULATOR THE DIVERTER VALVE IN DOMESTIC POSITION FOR A PERIOD OF TIME EQUAL TO THE POST-CIRCULATION (SEE PARAMETER P09), SO AS TO MAINTAIN THE SECONDARY EXCHANGER HOT.</p>	0 - 1	<p>0 = DISABLED (SET BY DEFAULT)</p> <hr/> <p>1 = ENABLED</p>
P07	<p>HEATING TIMING</p> <p>THROUGH THIS PARAMETER YOU CAN SET THE MINIMUM TIME FOR WHICH THE BURNER WILL BE TURNED OFF ONCE THE HEATING TEMPERATURE REACHED THE USER SET TEMPERATURE.</p>	0 - 90	<p>VALUE EXPRESSED IN MULTIPLES OF 5 SECONDS (PRE-SET AT $36 \times 5 = 180$ SECONDS)</p>
P08	<p>POST-CIRCULATION HEATING TIMING</p> <p>THROUGH THIS PARAMETER YOU CAN SET THE PUMP DURATION OF OPERATION DURING HEATING CYCLE, AFTER THE MAIN BURNER TURNS OFF DUE TO THE ENVIRONMENT THERMOSTAT.</p>	0 - 90	<p>VALUE EXPRESSED IN MULTIPLES OF 5 SECONDS (PRE-SET AT $36 \times 5 = 180$ SECONDS)</p>
P09	<p>POST-CIRCULATION DOMESTIC / BOILER TIMING</p> <p>THROUGH THIS PARAMETER YOU CAN SET THE PUMP OPERATION DURATION ON THE DOMESTIC CIRCUIT, AFTER THE TAP IS CLOSED.</p>	0 - 90	<p>VALUE EXPRESSED IN MULTIPLES OF 5 SECONDS (PRE-SET AT $18 \times 5 = 90$ SECONDS)</p>



PARAMETER	DESCRIPTION	RANGE	FUNCTION
P10	<p>DOMESTIC FAN MINIMUM SPEED ADJUSTMENT</p> <p>THROUGH THIS PARAMETER YOU CAN SET THE FAN MINIMUM SPEED IN DOMESTIC PHASE, THAT CORRESPONDS TO THE MINIMUM BURNER POWER DURING A REQUEST TO OPERATE IN DOMESTIC MODE. [SEE 2.1.6 'COMBUSTION BLOWER FREQUENCY/HEAT CAPACITY DIAGRAM'].</p> <p>THE VALUE IS PRE-SET BASED ON THE SET POWER (SEE PARAMETER P00) AND ON THE GAS TYPE (SEE PARAMETER P02).</p>	45 - VALUE SET FOR PARAMETER P11	THE VALUE IS EXPRESSED IN HERTZ (1HZ = 30 RPM)
P11	<p>DOMESTIC FAN MAXIMUM SPEED ADJUSTMENT</p> <p>THROUGH THIS PARAMETER YOU CAN SET THE FAN MAXIMUM SPEED IN DOMESTIC PHASE, THAT CORRESPONDS TO THE MAXIMUM BURNER POWER DURING A REQUEST TO OPERATE IN DOMESTIC MODE [SEE 2.1.6 'COMBUSTION BLOWER FREQUENCY/ HEAT CAPACITY DIAGRAM'].</p> <p>THE VALUE IS PRE-SET BASED ON THE SET POWER (SEE PARAMETER P00) AND ON THE GAS TYPE (SEE PARAMETER P02).</p>	V A L U E SET FOR PARAMETER P10 - 203	THE VALUE IS EXPRESSED IN HERTZ (1HZ = 30 RPM)
P12	<p>HEATING FAN MINIMUM SPEED ADJUSTMENT</p> <p>THROUGH THIS PARAMETER YOU CAN SET THE FAN MINIMUM SPEED IN HEATING PHASE, THAT CORRESPONDS TO THE MINIMUM BURNER POWER DURING A REQUEST TO OPERATE IN HEATING MODE. [SEE 2.1.6 'COMBUSTION BLOWER FREQUENCY/ HEAT CAPACITY DIAGRAM'].</p> <p>THE VALUE IS PRE-SET BASED ON THE SET POWER (SEE PARAMETER P00) AND ON THE GAS TYPE (SEE PARAMETER P02).</p>	45 - VALUE SET FOR PARAMETER P13	THE VALUE IS EXPRESSED IN HERTZ (1HZ = 30 RPM)
P13	<p>HEATING FAN MAXIMUM SPEED ADJUSTMENT</p> <p>THROUGH THIS PARAMETER YOU CAN SET THE FAN MAXIMUM SPEED IN HEATING PHASE, THAT CORRESPONDS TO THE MAXIMUM BURNER POWER DURING A REQUEST TO OPERATE IN HEATING MODE [SEE 2.1.6 'COMBUSTION BLOWER FREQUENCY/ HEAT CAPACITY DIAGRAM'].</p> <p>THE VALUE IS PRE-SET BASED ON THE SET POWER (SEE PARAMETER P00) AND ON THE GAS TYPE (SEE PARAMETER P02).</p>	V A L U E SET FOR PARAMETER P12 - 203	THE VALUE IS EXPRESSED IN HERTZ (1HZ = 30 RPM)
P14	<p>STARTING STEP ADJUSTMENT</p> <p>THROUGH THIS PARAMETER YOU CAN SET THE FAN SPEED DURING START-UP.</p> <p>THE VALUE IS PRE-SET BASED ON THE SET POWER (SEE PARAMETER P00) AND ON THE GAS TYPE (SEE PARAMETER P02).</p>	V A L U E SET FOR PARAMETER P10 - 203	THE VALUE IS EXPRESSED IN HERTZ (1HZ = 30 RPM) - (PRE-SET AT 120 HZ)



2. FIRST START-UP

PARAMETER	DESCRIPTION	RANGE	FUNCTION
P15	<p>ANTI-LEGIONELLA FUNCTION (ONLY FOR ACCUMULATION BOILER)</p> <p>THROUGH THIS PARAMETER YOU CAN ACTIVATE/DEACTIVATE "ANTI LEGIONELLA" HEAT TREATMENT OF THE ACCUMULATION BOILER. EVERY 7 DAYS THE WATER TEMPERATURE INSIDE THE ACCUMULATION BOILER IS HEATED BEYOND 140 °F (60 °C) THUS GENERATING A BURNING HAZARD. KEEP UNDER CONTROL SUCH DOMESTIC HOT WATER TREATMENT (AND INFORM THE USERS) TO AVOID UNFORESEEABLE DAMAGES TO PERSONS, ANIMALS, PROPERTY. A THERMOSTATIC VALVE SHOULD BE INSTALLED AT THE DOMESTIC HOT WATER OUTLET TO AVOID ANY BURNS.</p>	0 - 1	<p>0 = DISABLED</p> <hr/> <p>1 = ENABLED (PRE-SET BY DEFAULT ON ACCUMULATION BOILERS)</p>



PARAMETER	DESCRIPTION	RANGE	FUNCTION
P16	<p>CLIMATE COMPENSATION CURVE (ONLY WITH EXTERNAL PROBE CONNECTED)</p> <p>YOU CAN CONNECT AN EXTERNAL TEMPERATURE PROBE (SEE 1.1.16 'ELECTRICAL CONNECTIONS') THAT AUTOMATICALLY CHANGES THE DELIVERY TEMPERATURE BASED ON THE EXTERNAL MEASURED TEMPERATURE. THE NATURE OF THE CORRECTION DEPENDS ON THE THERMO-ADJUSTMENT VALUE KD SET (SEE CHART).</p> <p>THE SELECTION OF THE CURVE IS DETERMINED BY THE MAXIMUM DELIVERY TEMPERATURE T_m AND THE MINIMUM EXTERNAL TEMPERATURE T_e TAKING INTO ACCOUNT THE HOUSE INSULATION DEGREE.</p> <p>THE VALUES OF THE DELIVERY TEMPERATURES T_m, REFER TO STANDARD SYSTEMS 86-167 °F (30-75 °C) OR FLOOR SYSTEMS 77-113 °F (25-45 °C). THE SYSTEM TYPE CAN BE SET FROM PARAMETER P03.</p>	0 - 30	(SET BY DEFAULT AT 15) THE NUMBERING OF THE VALUE CORRESPONDS TO 'KD' CURVES ON THE CHART (SEE CHART BELOW).

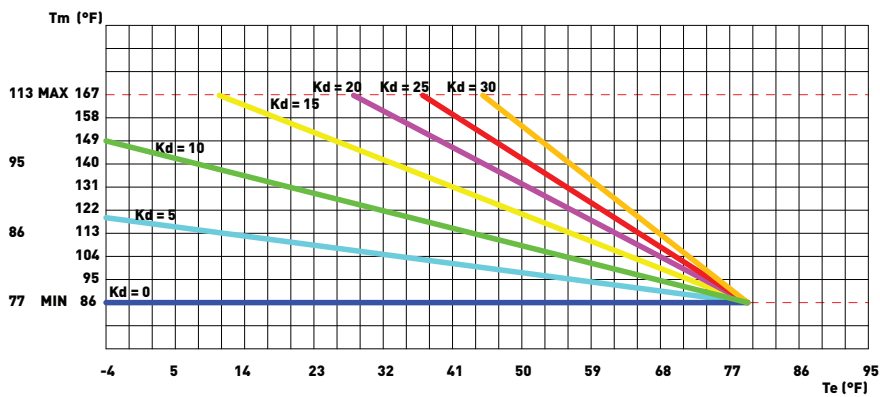

fig. 30

P17	<p>SETS THE TEMPERATURE MEASUREMENT UNIT</p> <p>THROUGH THIS PARAMETER YOU CAN SET THE TEMPERATURE MEASUREMENT UNIT DISPLAYED: CELSIUS (°C) OR FAHRENHEIT (°F) DEGREES.</p>	0 - 1	<p>0 = °C</p> <hr/> <p>1 = °F</p>
P18	<p>ENABLING BUS INDUSTRIAL PILOTING 0 - 10V</p> <p>THROUGH THIS PARAMETER YOU CAN ENABLE OR DISABLE THE BUS INDUSTRIAL INPUT 0-10V TO SET THROUGH EXTERNAL BUS THE BURNER POWER OR THE DELIVERY TEMPERATURE.</p>	0 - 2	<p>0 = DISABLED (SET BY DEFAULT)</p> <hr/> <p>1 = TEMPERATURE CONTROL MODE</p> <hr/> <p>2 = POWER CONTROL MODE</p>



2. FIRST START-UP

PARAMETER	DESCRIPTION	RANGE	FUNCTION
P19	MINIMUM HEATING SETPOINT THROUGH THIS PARAMETER YOU CAN SET THE USER-ADJUSTABLE MINIMUM HEATING TEMPERATURE.	68 - 104	THE VALUE IS EXPRESSED IN °F
P20	MAXIMUM HEATING SETPOINT THROUGH THIS PARAMETER YOU CAN SET THE USER-ADJUSTABLE MAXIMUM HEATING TEMPERATURE.	104 - 190	THE VALUE IS EXPRESSED IN °F
P21	MAXIMUM DOMESTIC SETPOINT THROUGH THIS PARAMETER YOU CAN SET THE USER-ADJUSTABLE MAXIMUM DOMESTIC TEMPERATURE.	113 - 167	THE VALUE IS EXPRESSED IN °F
P22	SET POINT ΔT DELIVERY-RETURN <i>(ONLY WITH MODULATING PUMP AND RETURN PROBE CONNECTED)</i> THROUGH THIS PARAMETER YOU CAN SET THE TEMPERATURE DIFFERENCE BETWEEN DELIVERY AND RETURN.	32 18 - 72	32 = DISABLED THE VALUE IS EXPRESSED IN °F
P23	MODULATING PUMP MINIMUM SPEED <i>(ONLY WITH MODULATING PUMP AND RETURN PROBE CONNECTED)</i> THROUGH THIS PARAMETER YOU CAN SET THE MINIMUM SPEED VALUE OF THE MODULATING PUMP DURING A REQUEST TO OPERATE IN HEATING MODE.	50 - 70	THE VALUE IS EXPRESSED IN PERCENTAGE
P24	MODULATING PUMP MAXIMUM SPEED <i>(ONLY WITH MODULATING PUMP AND RETURN PROBE CONNECTED)</i> THROUGH THIS PARAMETER YOU CAN SET THE MAXIMUM SPEED VALUE OF THE MODULATING PUMP DURING A REQUEST TO OPERATE IN HEATING MODE.	70 - 100	THE VALUE IS EXPRESSED IN PERCENTAGE
P25	D.H.W STORAGE TANK TEMPERATURE SETPOINT <i>(FOR STORAGE BOILERS ONLY)</i> THROUGH THIS PARAMETER YOU CAN SET THE PRIORITY STARTING VALUE OF THE STORAGE TANK, COMPARED TO THE USER ADJUSTABLE D.H.W SETPOINT.	37 - 48	THE VALUE IS EXPRESSED IN °F (PRE-SET AT 48 °F)
P26	MODBUS ADDRESS BY MEANS OF THIS PARAMETER, IT IS POSSIBLE TO SET THE ADDRESS OF THE BOARD ON MODBUS IN ORDER TO PERFORM A CASCADE SYSTEM.	0 1 - 16	0 = DISABLED (PRE-SET BY DEFAULT) BOILER NUMBERING FOR MODBUS



PARAMETER	DESCRIPTION	RANGE	FUNCTION
P27	<p>MODBUS COMMUNICATION BAUD RATE</p> <p>BY MEANS OF THIS PARAMETER, IT IS POSSIBLE TO SELECT THE MODBUS COMMUNICATION BAUD RATE SUPPORTED BY THE SAME INTERFACE.</p>	0 - 5	<p>0 = 9600</p> <hr/> <p>1 = 1200</p> <hr/> <p>2 = 2400</p> <hr/> <p>3 = 4800</p> <hr/> <p>4 = 9600</p> <hr/> <p>5 = 19200</p>
P28	<p>CONNECTION STATUS OF THE SOLAR AUXILIARY BOARD</p> <p>BY MEANS OF THIS PARAMETER, IT IS POSSIBLE TO ENABLE THE AUXILIARY BOARD FOR THE EXPANSION OF THE RESOURCES WHEN THE SOLAR AUXILIARY BOARD IS CONNECTED TO THE BOILER BOARD AUTOMATICALLY, THE VALUE OF THIS PARAMETER BECOMES '1', BUT IF THE SOLAR AUXILIARY BOARD IS SUCCESSIVELY DISCONNECTED, THE DISPLAY OF THE CONTROL PANEL OF THE BOILER WILL DISPLAY THE ERROR 'E31'. IN THIS CASE, IN ORDER TO DEACTIVATE THE ERROR 'E31', IT IS NECESSARY TO MANUALLY SET THE VALUE OF THE PARAMETER TO '0'.</p>	0 - 1	<p>0 = NOT INSTALLED</p> <hr/> <p>1 = INSTALLED</p>
P29	<p>MODBUS MODE ENABLING</p>	0 - 2	<p>0 = MODBUS ENABLED</p> <hr/> <p>1 = MODBUS ENABLED (WITH SOME SETTINGS TO BE ADJUSTED FROM THE BOILER CONTROL PANEL)</p> <hr/> <p>2 = MODBUS DISABLED</p>
P30	<p>OUTDOOR RESET FUNCTION</p>	0 - 1	<p>0 = 86-167 °F (30-75 °C)</p> <p>1 = STANDARD RESET FUNCTION 86-140 °F (30-60 °C) WITHOUT OUTDOOR TEMPERATURE SENSOR OR 86-167 °F (30-75 °C) WITH OUTDOOR TEMPERATURE SENSOR (SET BY DEFAULT).</p>



2. FIRST START-UP

PARAMETER	DESCRIPTION	RANGE	FUNCTION
P31	<p>ENABLING THE SAFETY CHECK, IN CASE OF INSUFFICIENT CIRCULATION UPON THE IGNITION.</p> <p>THE ACTIVATION OF THIS PARAMETER, AGAINST EACH IGNITION OF THE BURNER, LEADS TO THE VERIFICATION OF THE CORRECT OPERATION OF THE CIRCULATING PUMP. SHOULD THE PUMP NOT RUN CORRECTLY, THIS PROTECTS THE HEAT EXCHANGER, AS WELL THE OTHER PARTS THAT MIGHT BE AFFECTED BY THE UN-DISSIPATED HEAT.</p>	0 - 1	<p>0 = DISABLED</p> <hr/> <p>1 = ENABLED (PRE-SET BY DEFAULT)</p>



2.1.6. COMBUSTION BLOWER FREQUENCY/HEAT CAPACITY DIAGRAM

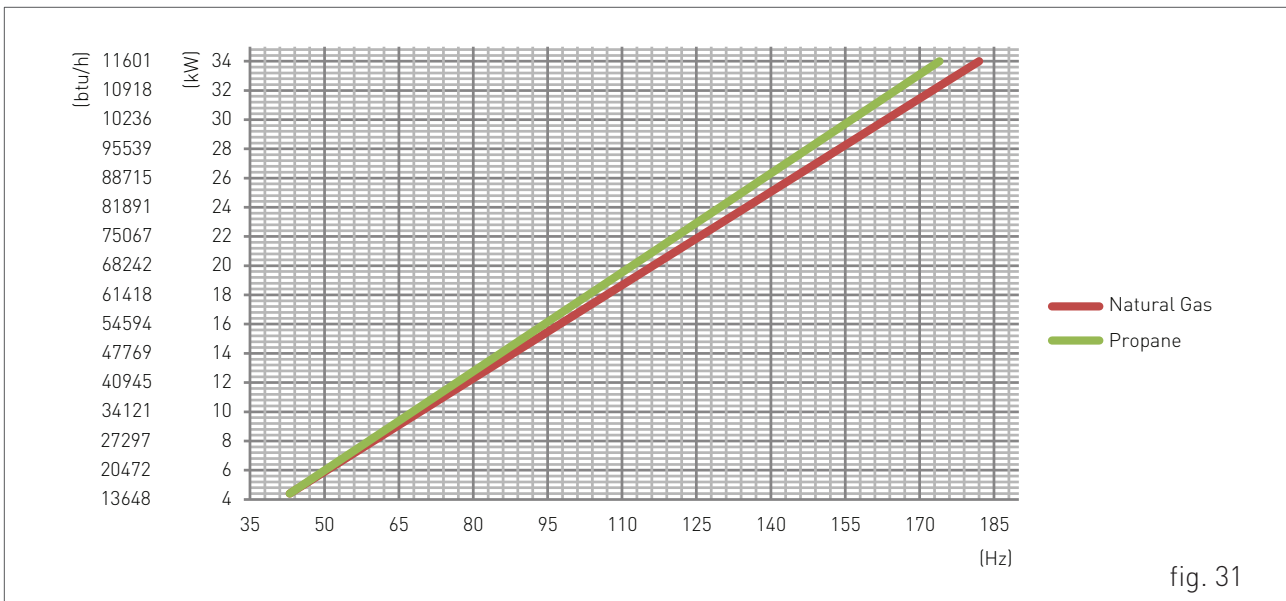

fig. 31

SUPPORT CENTER

GAS TYPE	MINIMUM HEATING FREQUENCY	MAXIMUM HEATING FREQUENCY	MINIMUM FREQUENCY IN DOMESTIC HOT WATER LINE	MAXIMUM FREQUENCY IN DOMESTIC HOT WATER LINE
Natural Gas	43 Hz	182	43	182
Propane	43 Hz	174	43	174

Note: The frequency would change based on vent length. See section '1.1.21 TABLE 1: ALLOWABLE VENT LENGTHS' for change on frequency with reference to vent lengths.

2.2. MAINTENANCE

2.2.7. GENERAL MAINTENANCE WARNINGS

**ATTENTION**

All maintenance operations must be performed by qualified staff and authorized by RADIANT BRUCIATORI spa.

**WARNING**

The maintenance operations must be performed once every twelve months starting from the boiler installation date.

**WARNING**

To ensure longer life span and proper operation of the device, during the maintenance operations use only original spare parts.

**DANGER**

Before each components cleaning or replacement operation, ALWAYS cut off the POWER, WATER and GAS supply of the boiler.

Please perform the following operations once a year:

- › check the pre-load pressure of the expansion tank;
- › check the sealing of the water components, and replace the gaskets if necessary;
- › check that the wiring is installed in compliance with the requirements in the boiler instruction manual;
- › check the wiring inside the control panel;
- › remove and clean the burner from oxidation;
- › check the integrity and the position of the sealed chamber sealing gasket;
- › check the primary exchanger, if necessary, clean it;
- › check the operation of the gas burner start up and safety systems. If necessary, remove and clean the flame detection and start up electrodes from incrustations paying attention to respect the distances with respect to the burner;
- › check the sealing of the gas components, and replace the gaskets if necessary;
- › visually check the flame and the condition of the combustion chamber;
- › if necessary make sure that the combustion is adjusted correctly and if required proceed as indicated in section 2.1.3 "CO₂ VALUE CHECK AND CALIBRATION";
- › periodically check the integrity of the venting system for safety and proper operation;
- › make sure that the permanent ventilation outlets are present, correctly sized and functioning, based on the in-stalled devices. Follow the requirements provided by Local and National legislation;
- › check the heating circuit safety systems: limit temperature safety thermostat; limit pressure safety;
- › check the proper operation of the condensate draining system, including the devices outside the boiler such as condensate collection devices installed along the path of the venting or neutralization devices for acid condensate. Check that the liquid flow is not obstructed and that there is no combustion gas build up inside the internal system;
- › check the flow and temperature of domestic hot water.



2.2.8. TECHNICAL DATA

Model	R2KA 34 /20	
Maximum nominal heat capacity in heating circuit	btu/h - (kW)	116013 - (34)
Maximum nominal heat capacity in domestic circuit	btu/h - (kW)	116013 - (34)
Minimum nominal heat capacity in heating circuit	btu/h - (kW)	15013 - (4.4)
Minimum nominal heat capacity in domestic circuit	btu/h - (kW)	15013 - (4.4)
Useful thermal power - 140/176°F (60/80°C)	btu/h - (kW)	113215 - (33.18)
Minimum useful thermal power - 140/176°F (60/80°C)	btu/h - (kW)	14706 - (4.31)
Performance at 100% Pn - 140/176°F (60/80°C)	%	97.6
CO ₂ at nominal heat capacity - Natural Gas	%	9.2 - 9.5
CO ₂ at minimum heat capacity - Natural Gas	%	8.9 - 9.2
CO ₂ at nominal heat capacity - Propane	%	10.3 - 10.6
CO ₂ at minimum heat capacity - Propane	%	10 - 10.3
CO at nominal heat capacity	ppm	65 - 150
CO at minimum heat capacity	ppm	1 - 20
Heating circuit		
Adjustable heating temperature	°F - (°C)	86-167 / 77-113 (30-75 / 25-45)
Maximum operating temperature for heating circuit	°F - (°C)	203 - (95)
Maximum operating pressure for heating circuit	psi - (bar)	60 - (4.1)
Minimum operating pressure for heating circuit	psi - (bar)	4.29 - (0.3)
Expansion tank pre-charge pressure	psi - (bar)	14.5 - (1)
Capacity of the system expansion vessel	gal(US) - (litres)	2.64 - (10)
Domestic circuit		
Adjustable domestic temperature	°F - (°C)	95-140 (35-60)
Maximum pressure for domestic circuit	psi - (bar)	150 - (10.34)
Minimum pressure for domestic circuit	psi - (bar)	7.25 - (0.5)
Storage cylinder capacity	gal(US) - (litres)	5.28 - (20)
Continuous hot water supply - ΔT 54°F (30°C) - mixed water - 1 hour	gal(US) - (litres)	267.9 - (1014)
Continuous hot water supply - ΔT 54°F (30°C) - mixed water - for the first 10 minutes	gal(US) - (litres)	47.95 (181.5)
Dimensional characteristics		
Width	in - (mm)	19.29 - (490)
Depth	in - (mm)	19.7 - (500)
Height	in - (mm)	35.43 - (900)
Gross weight	lb - (Kg)	151.7 - (68.8)
Water connections		
Flow	Ø	3/4" *
Cold water	Ø	1/2" *
Hot water	Ø	1/2" *
Gas	Ø	1/2" *
Return	Ø	3/4" *



2. MAINTENANCE

[*] NOTE: THESE ARE CONNECTION SIZES BEFORE VALVE KIT/CONNECTION CONVERSION KIT IS INSTALLED.

Electrical specifications

Voltage-frequency	V/Hz	120/60
Max Absorbed Power	W	78

Gas supply

Nominal supply pressure - Natural Gas	psi - (mbar)	0.25 - (17.4)
Heating Max. fan speed - Natural Gas	Hz	182
D.H.W Max fan speed - Natural Gas	Hz	182
Heating Min. fan speed - Natural Gas	Hz	43
D.H.W Min. fan speed - Natural Gas	Hz	43
Fuel consumption - Natural Gas	ft ³ /h - (m ³ /h)	114.41 - (3.24)
Nominal Supply pressure - Propane	psi - (mbar)	0.47 - (27.4)
Heating Max. fan speed - Propane	Hz	174
D.H.W Max fan speed - Propane	Hz	174
Heating Min. fan speed - Propane	Hz	43
D.H.W Min. fan speed - Propane	Hz	43
Fuel consumption - Propane	lb/h - (kg/h)	5.32 - (2.41)

2.2.9. TECHNICAL ASSEMBLY TECHNICAL ASSEMBLY

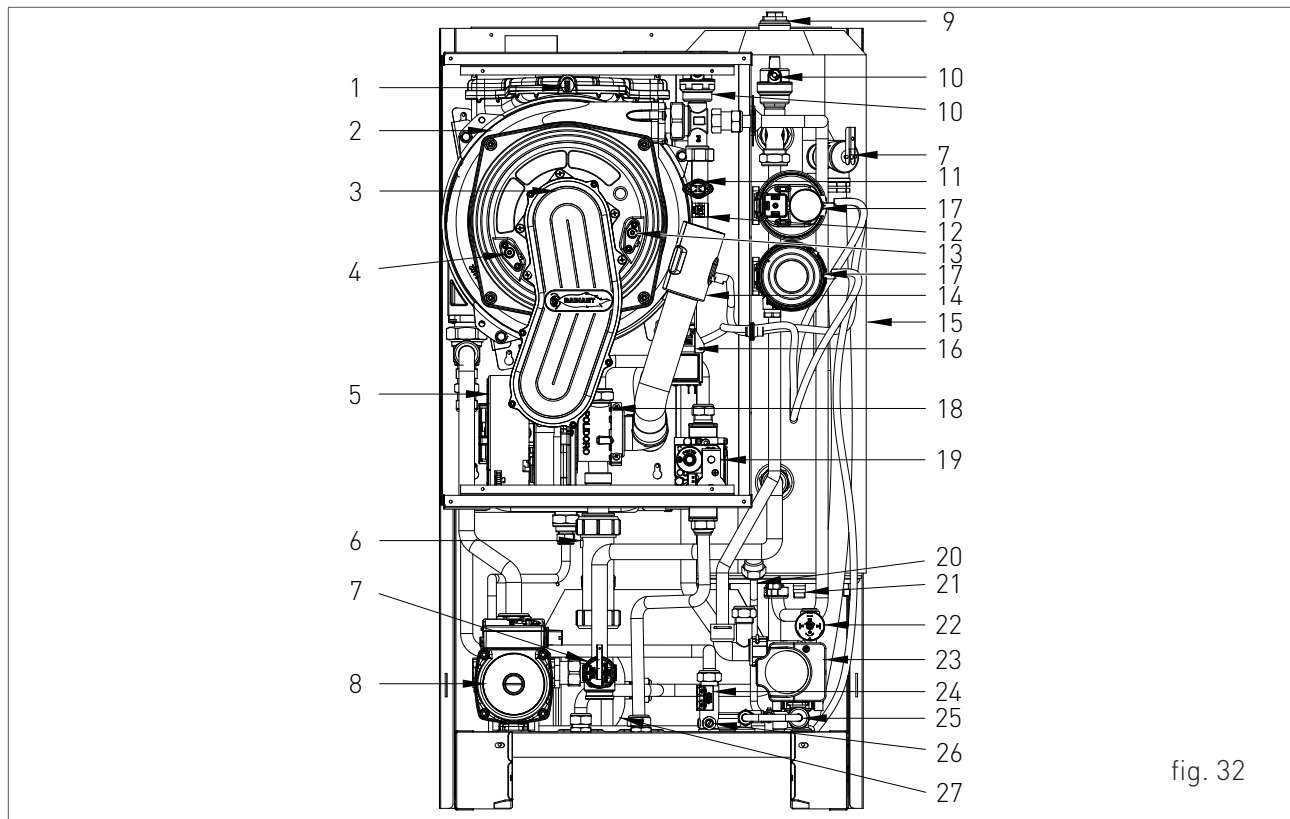
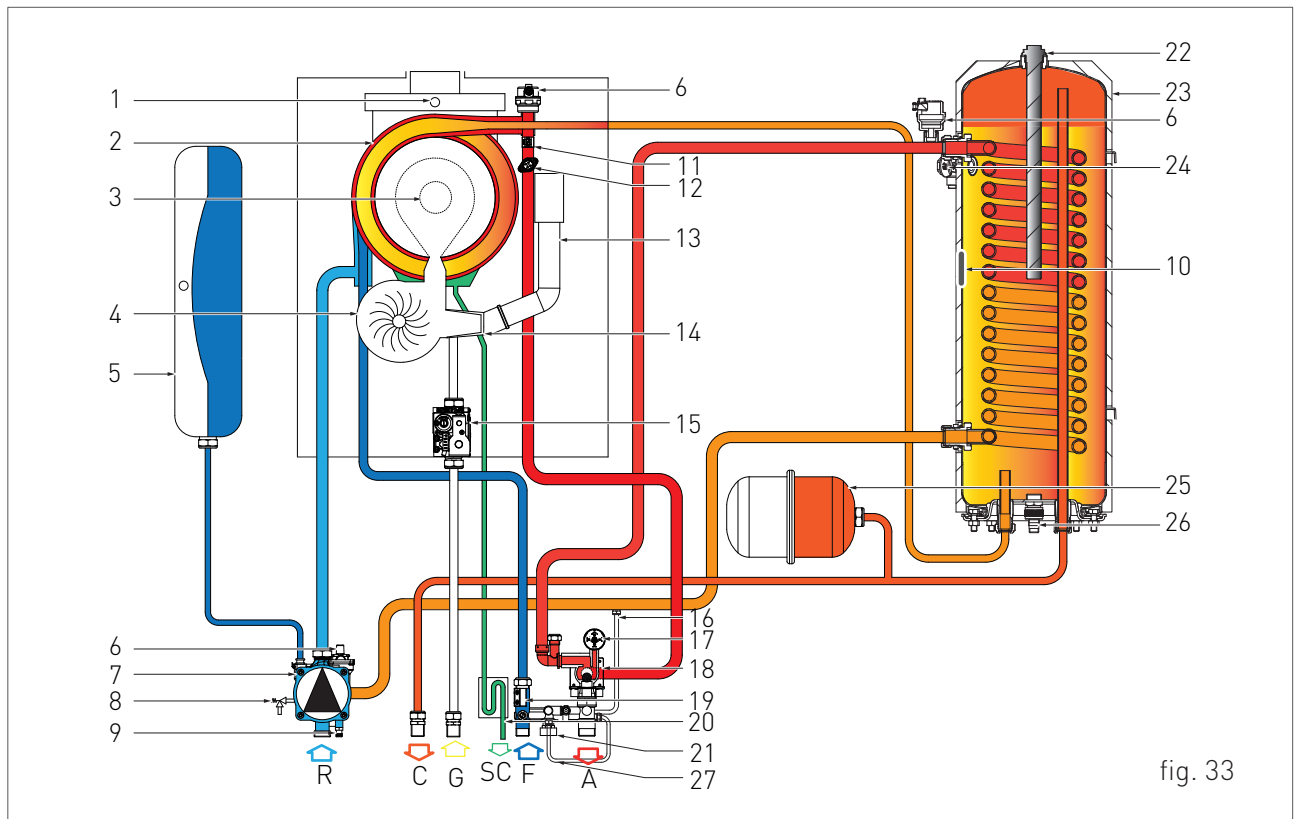

fig. 32

KEY

- | | |
|---|----------------------------|
| 1. EXHAUST SAFETY HIGH LIMIT SWITCH | 23. DIVERTER VALVE |
| 2. INTEGRATED HEAT EXCHANGER | 24. FLOW SWITCH |
| 3. BURNER UNIT | 25. CHECK VALVE |
| 4. IONIZATION ELECTRODE | 26. FLOW LIMITER |
| 5. COMBUSTION BLOWER | 27. THERMAL EXPANSION TANK |
| 6. CONDENSATE COLLECTION SIPHON | |
| 7. PRESSURE RELIEF VALVE | |
| 8. CIRCULATOR | |
| 9. ANODE | |
| 10. AIR ELIMINATOR | |
| 11. WATER TEMPERATURE HIGH LIMIT SWITCH | |
| 12. CENTRAL HEATING TEMPERATURE PROBE | |
| 13. SPARK ELECTRODE | |
| 14. AIR SUCTION TUBE | |
| 15. INDIRECT TANK | |
| 16. IGNITION TRANSFORMER | |
| 17. AIR PRESSURE SWITCH | |
| 18. PROPORTIONAL VENTURI | |
| 19. GAS VALVE | |
| 20. BY-PASS | |
| 21. TANK DRAINING TAP | |
| 22. WATER PRESSURE SWITCH | |

2.2.10. INTERNAL PIPING SCHEMATIC



KEY

- | | |
|---|--|
| R. CENTRAL HEATING RETURN | 11. CENTRAL HEATING TEMPERATURE PROBE |
| C. DOMESTIC HOT WATER OUTLET | 12. WATER TEMPERATURE HIGH LIMIT SWITCH |
| G. GAS INLET | 13. AIR SUCTION TUBE |
| SC. CONDENSATE DRAIN | 14. PROPORTIONAL VENTURI |
| F. COLD WATER INLET | 15. GAS VALVE |
| A. CENTRAL HEATING SUPPLY | 16. BY-PASS |
| | 17. WATER PRESSURE SWITCH |
| | 18. DIVERTER VALVE |
| 1. EXHAUST SAFETY HIGH LIMIT SWITCH | 19. FLOW SWITCH |
| 2. INTEGRATED HEAT EXCHANGER | 20. CONDENSATE COLLECTION SIPHON |
| 3. BURNER UNIT | 21. SYSTEM FILLING TAP |
| 4. COMBUSTION BLOWER | 22. ANODE |
| 5. THERMAL EXPANSION TANK | 23. INDIRECT TANK |
| 6. AIR ELIMINATOR | 24. PRESSURE RELIEF VALVE 150 psi (10.3 bar) |
| 7. CIRCULATOR | 25. THERMAL EXPANSION TANK D.H.W. |
| 8. PRESSURE RELIEF VALVE 30 psi (2 bar) | 26. TANK DRAINING TAP |
| 9. SYSTEM DRAINING TAP | 27. CHECK VALVE |
| 10. DOMESTIC TEMPERATURE PROBE | |



2.2.11. 3-WAY VALVE OPERATION

Important: The working position of the 3-way valve is indicated by the color (Red or Blue) visible in the inside of the valve. (see 'C' - fig. 34).

- › The RED color (with C-A) indicates the operation in the Domestic Hot water mode.
- › The BLUE color (with C-B) indicates the operation in Heating mode.

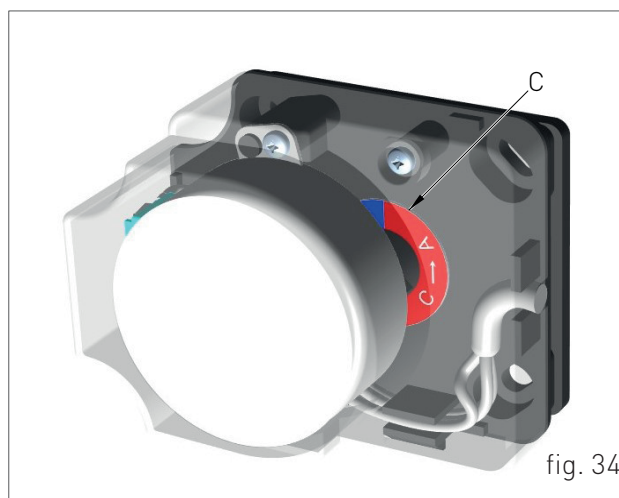

2.2.12. WIRING DIAGRAM

SUPPORT CENTER

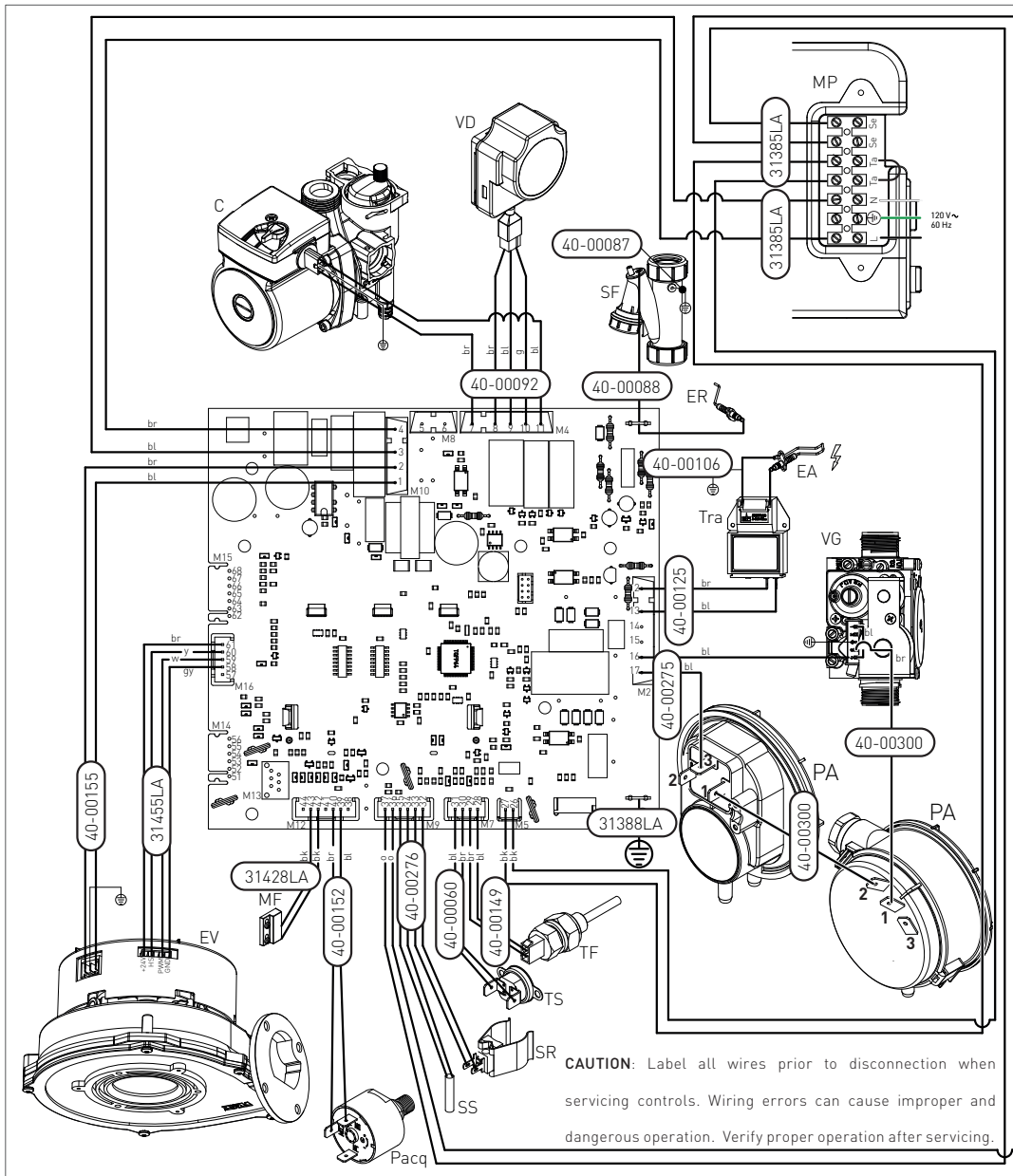

fig. 35

ER: IONIZATION ELECTRODE	TS: WATER TEMPERATURE HIGH LIMIT SWITCH	MP: PANEL TERMINAL	BL: BLUE
EA: SPARK ELECTRODE	PACQ: WATER PRESSURE SWITCH	SE: OUTDOOR TEMPERATURE	BR: BROWN
C: CIRCULATOR	MF: MICRO-FLOW SWITCH	TA: ENVIRONMENT THERMOSTAT	O: ORANGE
VG: GAS VALVE	SR: CENTRAL HEATING TEMPERATURE PROBE	L: LINE	Y: YELLOW
TRA: IGNITION TRANSFORMER	SS: DOMESTIC TEMPERATURE PROBE	N: NEUTRAL	W: WHITE
TF: EXHAUST SAFETY HIGH LIMIT SWITCH (102°C)	EV: COMBUSTION BLOWER	BK: BLACK	GY: GREY
VD: DIVERTER VALVE	PA: AIR PRESSURE SWITCH	G: GREEN	SF: CONDENSATE COLLECTION SIPHON

2.2.13. ACCESSING THE BOILER

For the majority of the control and maintenance operations you have to remove one or more panels of the casing.

The side panels can be removed only after removing the front panel.

To intervene on the front of the boiler proceed as follows:

- › grasp the front panel base and pull it outwards to release the two fixing pins (1 - fig. 36) placed at the bottom;
- › remove the front panel releasing one at a time the fixing pins at the top.

To intervene on the side panels of the boiler proceed as follows:

- › remove the fastening screws (2 - fig.36) placed on the side panel;
- › grab the bottom of the panel and remove it by moving it sideways and then pulling it upwards (see fig. 36).

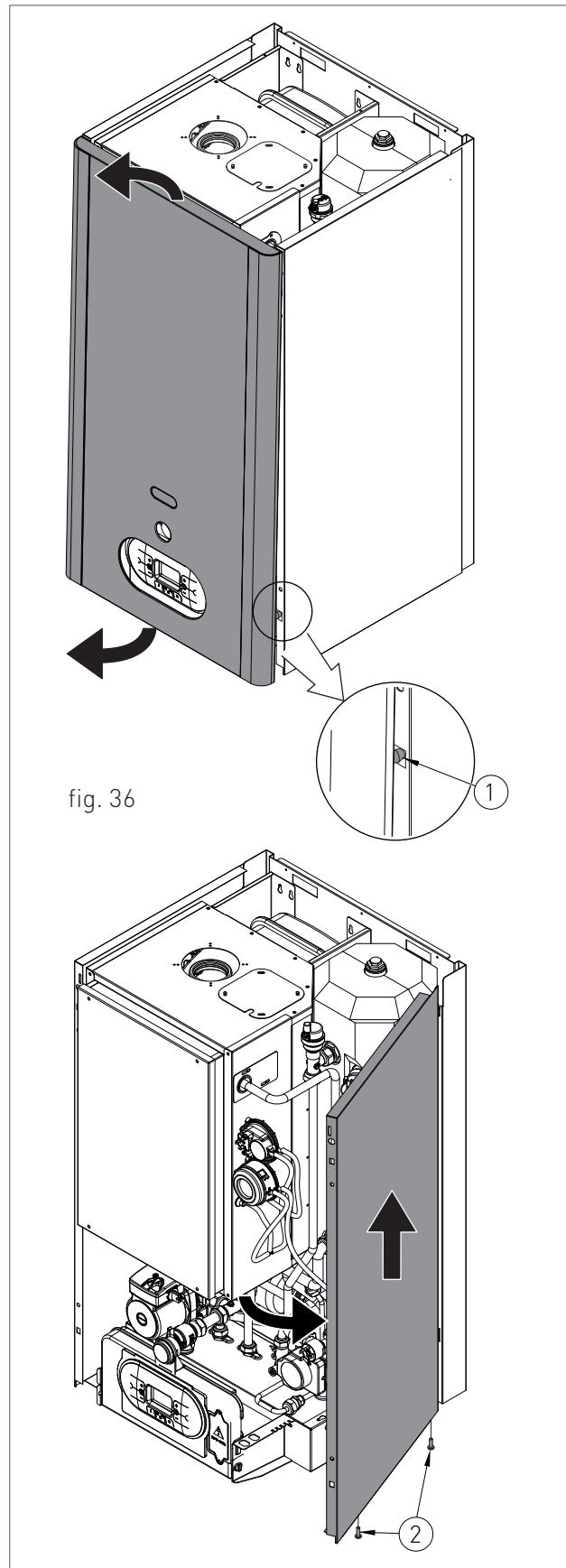

fig. 36

2.2.14. ACCESSING THE ELECTRONIC BOARD

In order to intervene on the wirings of the control panel, please proceed as follows:

**DANGER**

Cut off the voltage from the main switch.

- › Grab at the same time the support brackets of the control panel (fig. 37) loosening them and turn the panel downwards;
- › unscrew the four fastening screws 1 - fig. 37;
- › remove the crankcase pulling it upwards.

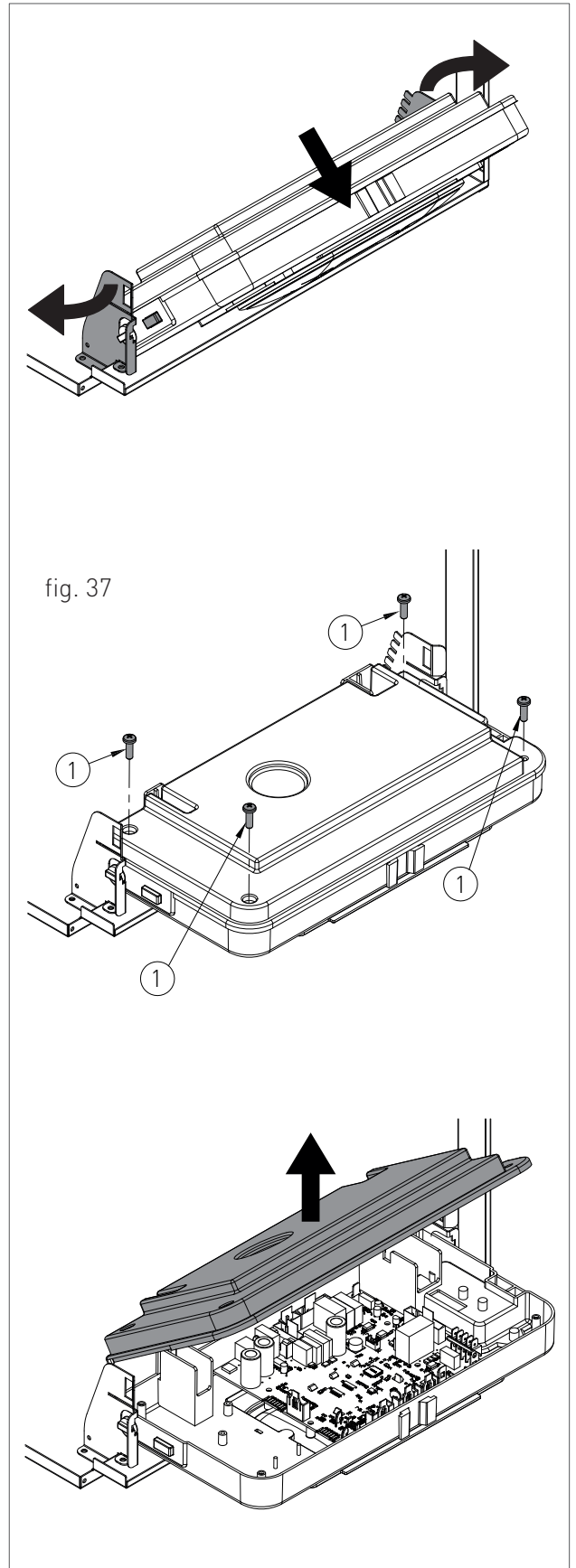

2.2.15. SYSTEM EMPTYING

HEATING SYSTEM EMPTYING

Whenever you need to empty the system, proceed as follows:

- › switch the boiler to "WINTER" mode and activate it;
- › turn off the main power supply switch or unplug the appliance;
- › wait for the boiler to cool down;
- › connect a flexible tube to the system emptying outlet and connect the other end of the tube to a suitable discharge;
- › turn the discharge tap of the system 'RS' (fig. 38);
- › open the relief valves of the radiators starting from the one at the top and continuing downwards;
- › after draining out all water, close the relief valves of the radiators and the emptying tap.

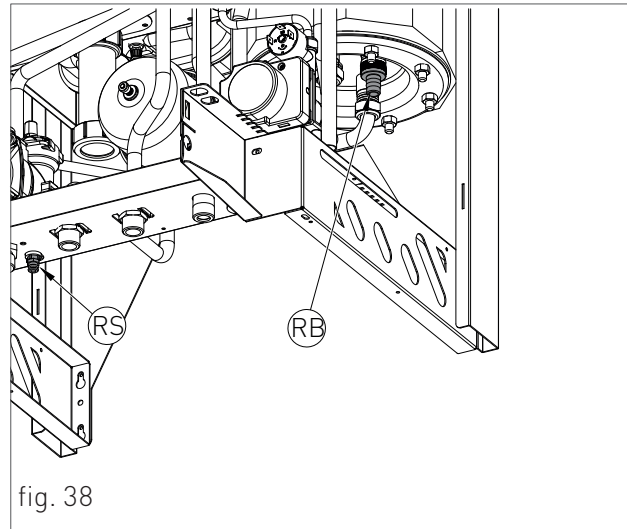

EMPTYING THE DOMESTIC SYSTEM

If there is freezing risk, you have to empty the domestic system as follows:

- › close the main supply tap of the water supply network;
- › Joint the water draining pipe and open the cylinder draining tap 'RB' (fig. 38)
- › open all cold and hot water taps;
- › after completing all operations, close the cylinder draining tap 'RB' (fig. 38) and all previously opened water taps.

2.2.16. BOILER MAINTENANCE

It's necessary to check and replace the magnesium anode after a year or more frequently if the quality and the water worn require it.





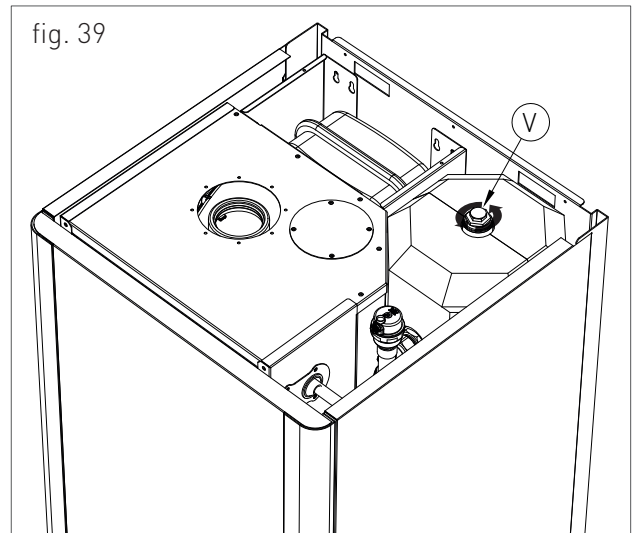

In order to check the anode functioning it's necessary to open the cap 'V' (fig.39) situated on the top of the boiler.

If during this operations there is a water leak, the anode has to be replaced because worn.





2.2.17. FAULT SIGNALLING CODES

To view the last 5 fault signalling codes chronologically, starting with the most recent one, activate the 'OFF' mode by pressing the FUNCTION  key and hold the key INFO  for 5 seconds. Use keys  and  of the heating circuit  to scroll through the list of saved faults. To reset the fault history press the RESET  key. To exit display mode press the INFO  key.



CODE	FAULT	POSSIBLE CAUSE	SOLUTION	RESET
E01	FLAME FAILURE	NO FLAME LIGHT UP		MANUAL RESET (PRESS THE RESET  KEY).
		NO GAS PRESSURE;	CHECK THE GAS SUPPLY;	
		MASS OR BROKEN START-UP ELECTRODE;	REPLACE IT;	
		GAS VALVE NOT OPENING;	REPLACE IT;	
		SLOW LIGHT UP TOO LOW ADJUSTMENT;	ADJUST MINIMUM OR SLOW LIGHT UP;	
		GAS SUPPLY PRESSURE TOO HIGH (ONLY FOR LP BOILERS).	CHECK THE MAXIMUM ADJUSTMENT PRESSURE (60 MBAR W.C. NOT BE EXCEEDED)	
		THE CONDENSATE LINE IS BLOCKED.	CHECK THE CONDENSATE LINE AND EMPTY/CLEAN THE CONDENSATE TRAP.	
		AIR PRESSURE SWITCH TRIPPED	CHECK VENTING, CHECK CABLE, REPLACE PART	
		WITH FLAME LIGHT UP		
		REVERSE POLARITY;	PROPERLY CONNECT THE POWER SUPPLY;	
		IONIZATION ELECTRODE BROKEN;	REPLACE IT;	
		IONIZATION ELECTRODE CABLE DISCONNECTED.	CHECK THE WIRING.	



2. MAINTENANCE

CODE	FAULT	POSSIBLE CAUSE	SOLUTION	RESET
E02	WATER TEMP. HIGH LIMIT SWITCH	THERMOSTAT CABLE DISCONNECTED;	CHECK THE WIRING;	MANUAL RESET (PRESS THE RESET Ⓡ KEY).
		BROKEN HIGH LIMIT.	REPLACE IT.	
E03	EXHAUST SAFETY HIGH LIMIT SWITCH	HIGH LIMIT BROKEN;	REPLACE IT;	MANUAL RESET (PRESS THE RESET Ⓡ KEY).
		HIGH LIMIT CABLE DISCONNECTED.	CHECK THE WIRING.	
E04	LOW WATER CUTOFF	INSUFFICIENT WATER PRESSURE INSIDE THE SYSTEM [LOWER THAN 4.3 psi (0.3 bar)]	LOAD THE SYSTEM;	AUTOMATIC.
		WATER PRESSURE SWITCH CABLE DISCONNECTED;	CHECK THE WIRING;	
		WATER PRESSURE SWITCH BROKEN.	REPLACE IT.	
E05	DOMESTIC INLET TEMPERATURE	BROKEN OR INCORRECTLY CALIBRATED PROBE (RESISTANCE VALUE 10 KOHM AT 77°F (25 °C) NTC);	REPLACE IT;	AUTOMATIC.
		DISCONNECTED OR WET PROBE CONNECTOR.	CHECK THE WIRING.	
E06	DOMESTIC INLET TEMPERATURE PROBE	BROKEN OR INCORRECTLY CALIBRATED PROBE (RESISTANCE VALUE 10 KOHM AT 77°F (25 °C) NTC);	REPLACE IT;	AUTOMATIC.
		DISCONNECTED OR WET PROBE CONNECTOR.	CHECK THE WIRING.	
E15	RETURN PROBE	BROKEN OR INCORRECTLY CALIBRATED PROBE (RESISTANCE VALUE 10 KOHM AT 77°F (25 °C) NTC);	REPLACE IT;	AUTOMATIC.
		DISCONNECTED OR WET PROBE CONNECTOR.	CHECK THE WIRING.	



CODE	FAULT	POSSIBLE CAUSE	SOLUTION	RESET
E16	COMBUSTION BLOWER	COMBUSTION BLOWER BOARD BROKEN;	REPLACE IT;	AUTOMATIC.
		COMBUSTION BLOWER BROKEN;	REPLACE IT;	
		FAULTY POWER SUPPLY CABLE.	REPLACE IT.	
E18	INSUFFICIENT CIRCULATION	FAULTY POWER SUPPLY CABLE OF THE CIRCULATOR PUMP.	REPLACE IT.	MANUAL RESET (PRESS THE RESET  KEY).
		CIRCULATOR PUMP BROKEN OR DIRTY IMPELLER.	CLEAN THE IMPELLER OR REPLACE THE CIRCULATOR PUMP.	
E21	GENERAL INTERNAL BOARD ERROR	INCORRECT SIGNAL RECOGNITION BY THE MODULATION BOARD MICRO-PROCESSOR.	IF THE MODULATION BOARD DOES NOT RESET THE ERROR AUTOMATICALLY, REPLACE IT.	AUTOMATIC.
E22	PARAMETERS PROGRAMMING REQUEST	MICRO=PROCESSOR MEMORY LOSS.	REPROGRAM PARAMETERS.	MANUAL RESET (DISCONNECT MAIN POWER SUPPLY).
E35	RESIDUAL FLAME	FAULTY IONIZATION ELECTRODE;	CLEAN IT OR REPLACE IT;	MANUAL RESET (PRESS THE RESET  KEY).
		FAULTY IONIZATION ELECTRODE CABLE;	REPLACE IT;	
		FAULTY MODULATION BOARD.	REPLACE IT.	
E40	SUPPLY VOLTAGE	SUPPLY VOLTAGE OUT OF THE OPERATION RANGE.	CHECK THE POWER SUPPLY LINE (THE ERROR DEACTIVATES AUTOMATICALLY AS SOON AS THE SUPPLY VOLTAGE FALLS BACK WITHIN THE REQUESTED LIMITS).	AUTOMATIC.



2. MAINTENANCE

2.2.18. ACTIVE FUNCTIONS SIGNALLING CODES

CODE	FUNCTION	DESCRIPTION
F07	CHIMNEY SWEEP ACTIVE	YOU CAN ACTIVATE IT BY HOLDING FOR 7 SECONDS THE RESET  KEY AND YOU CAN DEACTIVATE IT BY TURNING OFF THE BOILER. THIS FUNCTION BRINGS THE BOILER TO ITS MINIMUM AND MAXIMUM HEATING POWER FOR 15 MINUTES DEACTIVATING THE MODULATION FUNCTION. GENERALLY USED FOR PERFORMING THE COMBUSTION AND CALIBRATION TESTS.
F08	HEATING CIRCUIT ANTI-FREEZE	IT ACTIVATES AUTOMATICALLY WHEN THE HEATING PROBE DETECTS A TEMPERATURE OF 32.9°F (5°C). THE BOILER OPERATES AT MINIMUM GAS PRESSURE WITH THE DIVERTER VALVE SET TO 'WINTER' MODE. IT DEACTIVATES WHEN THE HEATING PROBE DETECTS A TEMPERATURE OF 86°F (30°C).
F09	D.H.W CIRCUIT ANTI-FREEZE	THE FUNCTION IS AUTOMATICALLY ENABLED WHEN THE D.H.W SENSOR DETECTS A TEMPERATURE OF 39.2°F (4 °C). THE BOILER OPERATES AT MINIMUM GAS PRESSURE WITH THE DIVERTER VALVE IN THE 'SUMMER' POSITION. THE FUNCTION IS DISABLED WHEN THE TEMPERATURE DETECTED BY THE SENSOR IS 46.4°F (8 °C) IN THE D.H.W CIRCUIT.
F28	ANTI-LEGIONELLA	THE FUNCTION IS ACTIVATED FOR THE FIRST TIME, 60 MINUTES AFTER THAT THE BOILER HAS BEEN ELECTRICALLY POWERED. STARTING FROM THAT MOMENT IT COMES AUTOMATICALLY INTO OPERATION EVERY 7 DAYS, BRINGING THE HOT WATER TEMPERATURE OF THE STORAGE CYLINDER UP TO 140°F (60°C). THIS FUNCTION IS ENABLED INDEPENDENTLY FROM THE CONTACT TO THE CYLINDER CLOCK, PROVIDING THAT THE RELATIVE PARAMETER (P15) IS ENABLED.
F33	SYSTEM AIR RELEASE CYCLE	IT ACTIVATES AUTOMATICALLY AT FIRST BOILER START-UP, PERFORMING FOR 5 MINUTES A SERIES OF CYCLES DURING WHICH THE PUMP IS ACTIVATED FOR 40 SECONDS AND DEACTIVATED FOR 20 SECONDS. REGULAR OPERATION IS ALLOWED ONLY AFTER THIS FUNCTION IS COMPLETED. IT CAN ALSO ACTIVATE DURING NORMAL BOILER OPERATION, IF THE WATER PRESSURE SWITCH CONFIRMATION IS MISSING, WHEN THE CONTACT IS RE-CLOSED, A 2 MINUTES RELEASE CYCLE WILL BE PERFORMED.

2.2.19. CONVERSION TO A DIFFERENT GAS TYPE



ATTENTION

Make sure that the gas induction tube is suitable for the new type of fuel with which the boiler is supplied.

- > loosen the two screws '1' [fig. 40] from the fastening clamp, and remove the air suction tube;
- > unscrew the tube coupling that connects the gas valve to venturi;
- > unscrew the three fastening screws '2' [fig. 40] of the venturi 'V' [fig. 40] using a 10 key, as shown in figure 41;
- > remove the two screws '3' [fig. 42] and apply pressure on the rear side of venturi 'C' [fig. 42];
- > replace the body venturi with the one suitable for the type of supply gas (cod. 30-00207 for methane / cod. 30-00237 for PROPANE) and make sure the tooth 'D' [fig.42] is adjusted downwards on the aluminium ring nut (see fig. 42);
- > remount the components following the demounting operations in reverse making sure that gasket 'G' is re-assembled as shown in fig. 40;
- > set the boiler to operate with the new type of gas, changing the value of the parameter P02 'GAS TYPE SELECTION' from the control panel (see 2.1.5 'DIGITECH CS PARAMETERS TABLE' and 2.1.4 'ACCESSING AND PROGRAMMING THE PARAMETERS');
- > adjust the CO₂ combustion value as indicated in 2.1.3 'CO₂ VALUE CHECK AND CALIBRATION'.

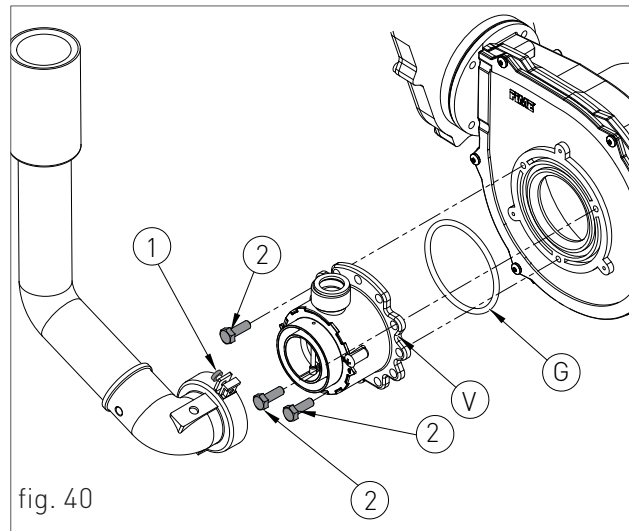

fig. 40

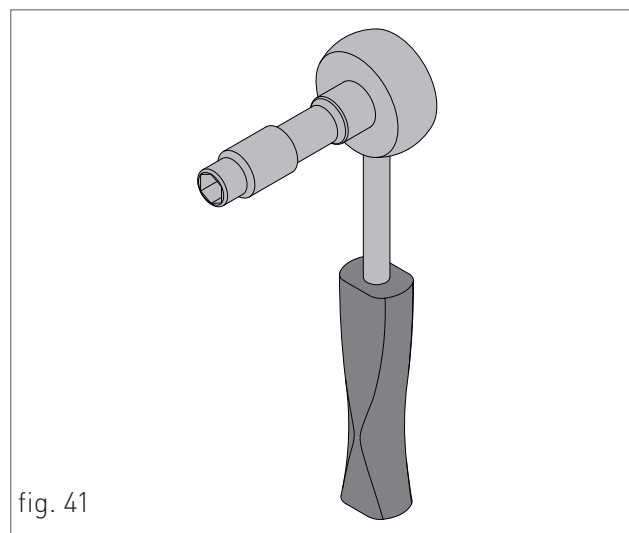

fig. 41

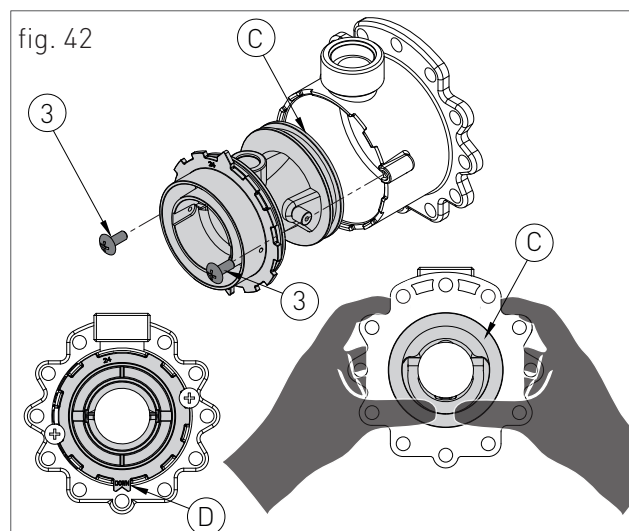

fig. 42



2.2.20. POSITIONS OF THE ELECTRODES

If the boiler does not restart, check the positions of the electrodes (especially the ignition electrode).

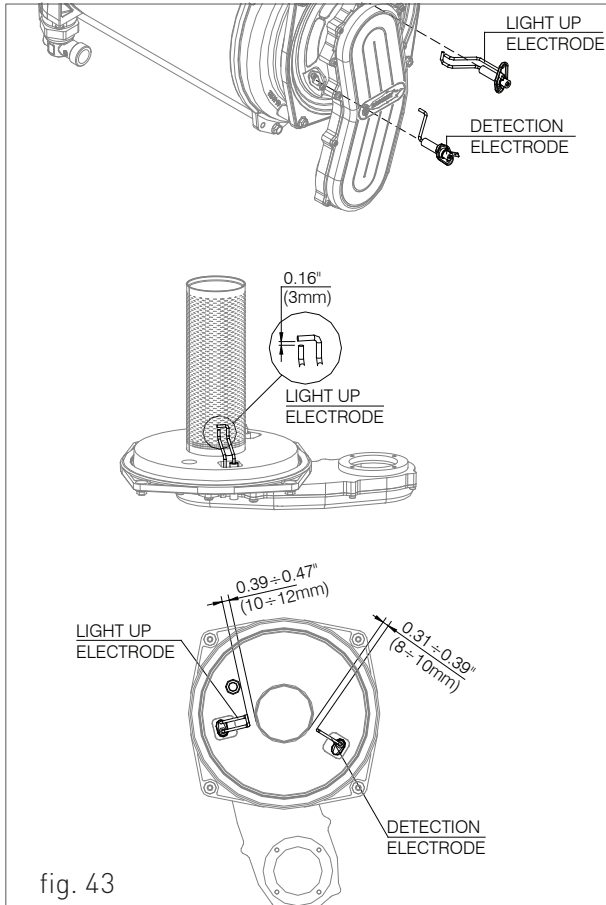

fig. 43



RADIANT BRUCIATORI s.p.a.

Via Pantanelli, 164/166 - 61025 Loc. Montelabbate (PU)

Tel. +39 0721 9079.1 • fax. +39 0721 9079279

e-mail: info@radiant • Internet: <http://www.radiant.it>