



Installation and Maintenance Manual for model

QUATTRO

SFK 57



WARNING

If the information in these instructions is not followed exactly, a fire or explosion may result causing property damage, personal injury or death.

FOR YOUR SAFETY

— Do not store or use gasoline or other flammable vapors and liquids in the vicinity of this or any other appliance.

— WHAT TO DO IF YOU SMELL GAS

- Do not try to light any appliance.
- Do not touch any electrical switch; do not use any phone in your building.
- Immediately call your gas supplier from a neighbor's phone. Follow the gas supplier's instructions.
- If you cannot reach your gas supplier, call the fire department.

— Installation on and service must be performed by a qualified installer, service agency or the gas supplier.





SUMMARY

INTRODUCTION 4

1. INSTALLER SECTION 7

1.1. INSTALLATION 8

1.1.1. GENERAL INSTALLATION WARNINGS 8

1.1.2. WATER HEATER LOCATION ENVIRONMENTAL REQUIREMENTS 8

1.1.3. REFERENCE LEGISLATION 9

1.1.4. UNPACKING 10

1.1.5. OVERALL DIMENSIONS (inch) 11

1.1.6. POSITIONING AND CLEARANCES TO COMBUSTIBLE MATERIAL AND SERVICE CLEARANCES 12

1.1.7. CIRCULATOR PERFORMANCE CURVE 13

1.1.8. WATER CONNECTION 15

1.1.9. PIPING DIAGRAM FOR BASIC INSTALLATION 16

1.1.10. PIPING DIAGRAM FOR RECIRCULATION MODE 17

1.1.11. PIPING DIAGRAM FOR COMBINATION MODE (DHW + HEATING) 17

1.1.12. CONDENSATE DRAIN 18

1.1.13. ANTI-FREEZE PROTECTION 20

1.1.14. GAS CONNECTION 21

1.1.15. ELECTRICAL CONNECTION 21

1.1.16. POWER SUPPLY 23

1.1.17. OPTIONAL ELECTRICAL CONNECTIONS 24

1.1.18. VENTING 26

1.1.19. TYPES OF EXHAUST SYSTEMS 29

1.1.20. TABLE 1: ALLOWABLE VENT LENGTHS 34

2. SUPPORT CENTRE SECTION 37

2.1. FIRST START-UP 38

2.1.1. PRELIMINARY OPERATIONS FOR FIRST START-UP 38

2.1.2. WATER HEATERS COMMISSIONING 39

2.1.3. CO2 VALUE CHECK AND CALIBRATION 40

2.1.4. ACCESSING AND PROGRAMMING THE PARAMETERS 41

2.1.5. PARAMETERS TABLE 43

2.1.6. COMBUSTION BLOWER FREQUENCY/HEAT CAPACITY DIAGRAM 50

2.2. MAINTENANCE 51

2.2.7. GENERAL MAINTENANCE WARNINGS 51

2.2.8. TECHNICAL DATA 53

2.2.9. TECHNICAL ASSEMBLY 55

2.2.10. INTERNAL PIPING SCHEMATIC 56

2.2.11. WIRING DIAGRAM 58



2.2.12. ACCESSING THE WATER HEATERS.....	59
2.2.13. ACCESSING THE ELECTRONIC BOARD.....	60
2.2.14. EMPTYING THE DOMESTIC SYSTEM.....	61
2.2.15. FAULT SIGNALLING CODES.....	62
2.2.16. ACTIVE FUNCTIONS SIGNALLING CODES.....	66
2.2.17. POSITIONS OF THE ELECTRODES.....	67
2.2.18. CONVERSION TO A DIFFERENT GAS TYPE.....	68
2.2.19. BOILER MAINTENANCE.....	69



INTRODUCTION

WARNING

Before starting any operation it is mandatory to read this instruction manual, in relation to the activities performed as described in each relevant section. Proper operation and optimal performance of the water heaters are ensured by strict compliance with all the instructions given in this manual.

The installation, use and maintenance manual is an integral and essential part of the product and must be delivered to the user.

MANUAL USERS

The manual users are all those who install, use and maintain the water heaters.

The water heaters must be used and accessed only by qualified operators that fully read and understood the use and maintenance manual, paying particular attention to the warnings.

READING AND SYMBOLS OF THE MANUAL

To ease the understanding of this manual, recurrent symbols where used, in particular:

- › On the outer margin of the page is placed a thumb index indicating the type of user to which the instructions in that section address.
- › The titles are differentiated by thickness and size in accordance with their hierarchy.
- › The images contain important parts described in the text, marked with numbers or letters.
- › (See chap “chapter# name”): this entry indicates another section in the Manual that you should refer to.

- › Unit: this term is used referring to the water heaters.



DANGER

It identifies information related to a general danger that if not complied with, may cause serious personal damage or even death.



ATTENTION

It identifies information that if not complied with may cause small or medium level burns to the person or serious damage to the water heaters.



WARNING

It identifies a precaution information that must be observed in order to avoid damaging the machine or various parts.

MANUAL STORAGE

The manual must be carefully stored and replaced in case of deterioration and/or low legibility.

If you misplace the use and maintenance manual, you can request a copy from the Technical Support Center providing. It is important to provide the model number and serial number of the unit which is found on the inside surface of the right panel



MANUFACTURER WARRANTY AND RESPONSIBILITY

The Manufacturer's warranty is provided only through authorized Technical Support Centers, listed for each Region on the site www.radianthydronics.com, and covers all manufacturing defects at the time of sale.

The technical and functional features of the unit are ensured when proper installation and maintenance is carried out. Conditions of Manufacturer's warranty includes the following.

1. The customer is aware of and follows instructions contained in the manuals that accompany the product.
2. Annual service check up is required to keep warranty valid.
3. The unit is installed and operated in the conditions in which it is designed to.

For more information on the warranty validity, its duration, the obligations and the exemptions, please consult the First start-up certificate attached to this manual.

The manufacturer reserves:

- › The right to modify the tools and relative technical documentation without any obligation to third parties;
- › The material and intellectual ownership of this manual and forbids its distribution and duplication, even partial, without prior written authorization.

PRODUCT CONFORMITY

RADIANT BRUCIATORI spa with reference to CSA/ANSI Z21.10.3:19 GAS-FIRED Water heaters, declares that its gas water heaters are professionally manufactured.

The materials used such as copper, brass, stainless steel create a homogeneous, compact and functional assembly, easy to install and maintain. The water heaters are equipped with all accessories necessary to provide a dependable independent heating unit. All water heaters are tested and delivered with a quality certificate signed by the testing department.



1. INSTALLER SECTION

The installation operations described in this section should be performed only by qualified personnel, having the appropriate technical training in the field for the installation and maintenance of components of civil and industrial domestic hot water production and heating plants.



1.1. INSTALLATION

1.1.1. GENERAL INSTALLATION WARNINGS

This water heater must be installed in accordance with local codes, if any; if not, follow the National Fuel Gas Code, ANSI Z223.1/NFPA 54, or the Natural Gas and Propane Installation Code, CAN/CSA B149.1, as applicable.



WARNING

This unit may be used only for the purpose for which it has been designed: heat water to a temperature below boiling point at atmospheric pressure. Any other use is considered wrong and dangerous. The manufacturer is excluded from any contractual or out of contract responsibility for damage caused to people, animals or property due to errors during installation.



WARNING

This water heater should be installed only by qualified personnel, having the appropriate technical training in the field for the installation and maintenance of components of civil and industrial domestic hot water production and heating plants.



WARNING

After having removed the packing, make sure the equipment is intact. In case of doubt, do not use the equipment and contact the supplier.

BEFORE INSTALLING THE WATER HEATER THE INSTALLER MUST MAKE SURE THAT THE FOLLOWING CONDITIONS ARE PRESENT:

- › The unit is connected to a heating unit and a water supply network appropriate for its power and performance.
- › When using room air for combustion, the location must be properly vented through an air vent.

- › A temperature and pressure relief valve , rated for 150 psi and 210F, is factory installed with the appliance. No valve is to be placed between the relief valve and the tank. The discharge from temperature and pressure relief valves will be conducted to a suitable place for disposal when relief occurs and no reducing coupling or other restriction be installed in the discharge line. The discharge line be installed to allow complete drainage of both the valve and line.
- › The unit is suitable for use with the type of gas available by checking the water heater data plate placed on the inner side of the front casing.
- › Make sure that the gas lines are properly sealed without any gas leaks.
- › Make sure that the grounding system works properly.
- › Make sure that the electrical system is suitable for the maximum power required by the equipment, value indicated on the data plate.



WARNING

Use only original RADIANT optional or kit accessories (including electrical).

1.1.2. WATER HEATER LOCATION ENVIRONMENTAL REQUIREMENTS

The water heater shall be installed so the gas ignition system components are protected from water (dripping, spraying, rain, etc.) during appliance operation and service (circulator replacement, condensate trap, control replacement, etc.).

The water heater installed using inside air supply must provide provisions for Combustion Air and Ventilation Air in accordance with section 5.3, Air



for Combustion and Ventilation, of the National Fuel Gas Code, ANSI Z 223.1/NFPA 54, or section 7.2, 7.3, or 7.4, of CAN/CSA B 149, Installation Codes, or local codes having jurisdiction.

Where an exhaust fan or any other air consumption appliance is installed in the same space as the water heater, sufficient air openings must be available to provide fresh air when all appliances are operating simultaneously. It is essential that in rooms where the water heater is installed to provide as much air as required by normal combustion of the gas consumed by the various appliances. Consequently, it may be necessary to make openings in the walls to provide the air inlet into the rooms.

For applications where air from the structure is used to supply combustion air for the unit, the following openings are required:

1. Have a total free section of a least 25 mm² every kW (1 in² for every 1000 Btu/hr) of heat input, with a minimum of 100 cm² (15.5 in²);
2. Where required by code or when required for additional opening must be provided at the highest practical elevation.

With a hermetically sealed combustion chamber and air supply circuit from outdoors, the water heater may be installed in any room in the home. Keep water heater area clear and free from combustible materials, gasoline and other flammable vapors and liquids.

The appliance should be located in an area where leakage of the tank or connections will not result in damage to the area adjacent to the appliance or to lower floors of the structure. When such locations cannot be avoided, it is recommended that a suitable drain pan, adequately drained, be installed under the appliance. The pan must not restrict combustion air flow.

**WARNING**

If the temperature in the water heaters installation location goes below 35.6°F (2°C) , insert an electrical resistances kit .

1.1.3. REFERENCE LEGISLATION

This water heater must be installed in accordance with local codes, if any; if not, follow the National Fuel Gas Code, ANSI Z223.1/NFPA 54, or the Natural Gas and Propane Installation Code, CAN/CSA B149.1, as applicable.

1.1.4. UNPACKING



WARNING

Please unpack the unit just before installing it. The Company is not responsible for the damages caused to the unit due to incorrect storage.



WARNING

The packing elements (cardboard box, wooden crate, nails, fasteners, plastic bags, expanded polystyrene, etc.) are dangerous and must be kept out of the reach of children. They should be discarded properly.

To unpack the water heaters, proceed as follows:

- › cut the fixing strip (see A-fig.1);
- › remove the cardboard box lifting it upwards (see B-fig.1);
- › push the water heater on one side and remove the pallet underneath (see C-fig.1).

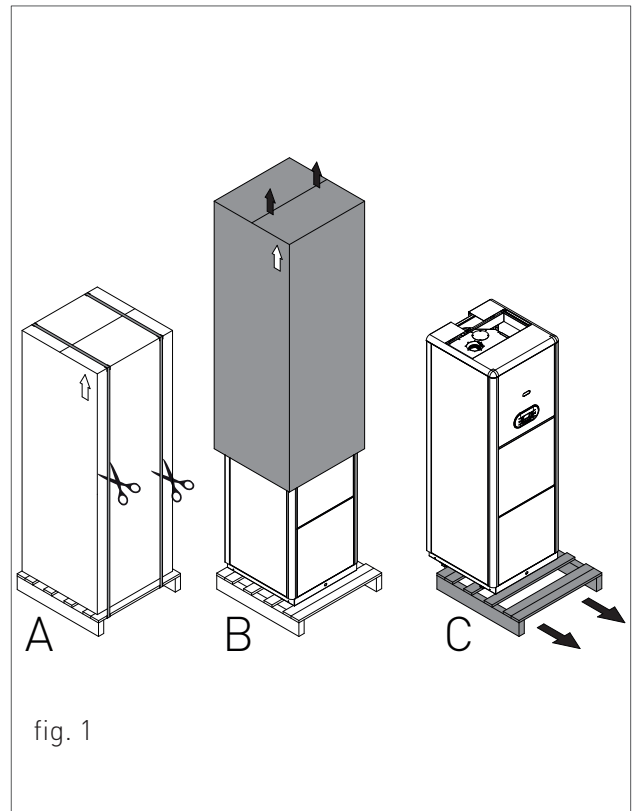



1.1.5. OVERALL DIMENSIONS (inch)

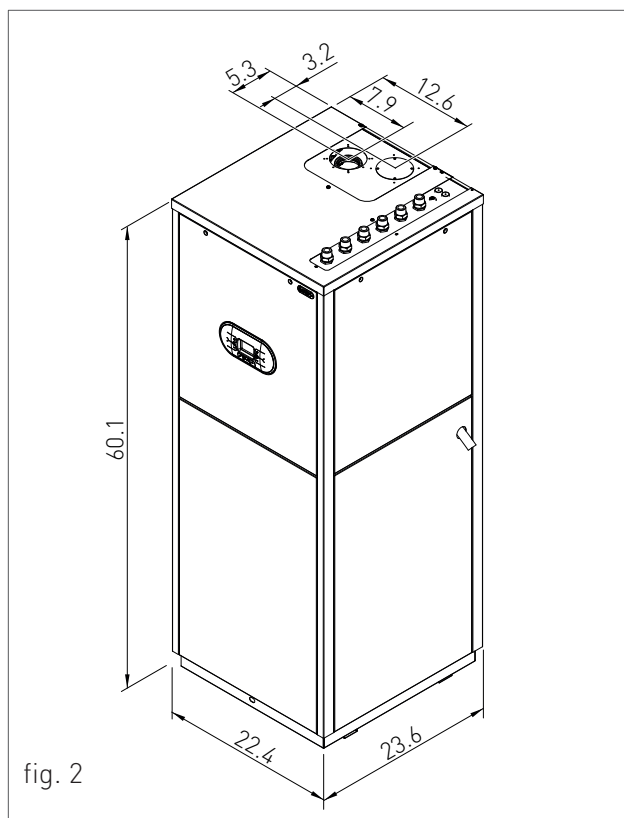
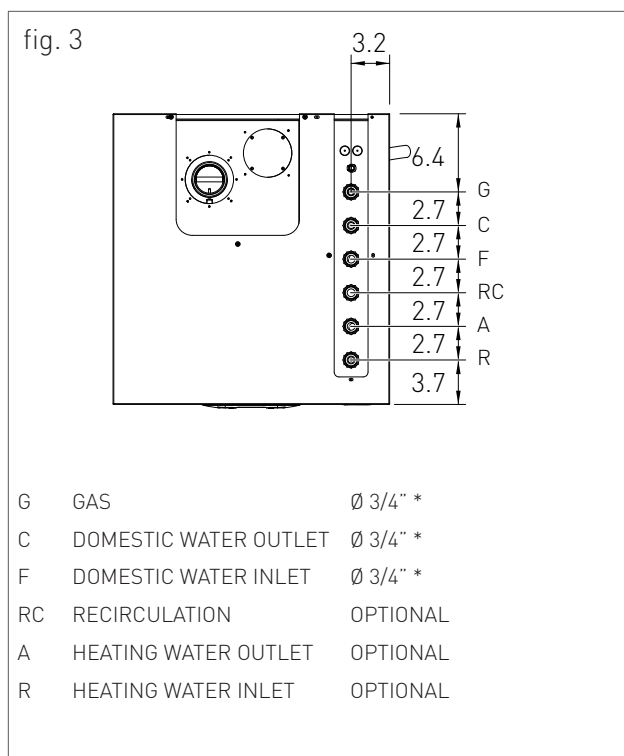

fig. 2



(*) NOTE: THESE ARE CONNECTION SIZES BEFORE VALVE KIT/CONNECTION CONVERSION KIT IS INSTALLED.

HYDRAULIC CONNECTION KIT

An hydraulic kit equipped with hydraulic connections is supplied by RADIANT.

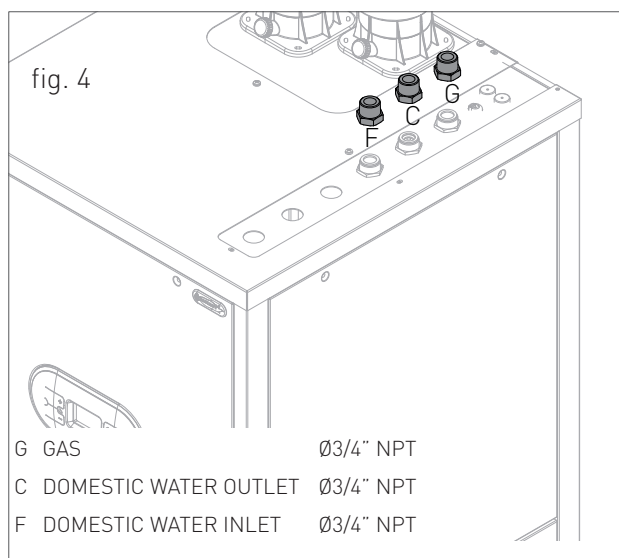

fig. 4



1. INSTALLATION

1.1.6. POSITIONING AND CLEARANCES TO COMBUSTIBLE MATERIAL AND SERVICE CLEARANCES

The appliance must be installed exclusively on a flat horizontal solid floor capable of supporting its weight.

This water heaters has been certified to be installed with "0" clearances to combustible material.

In order to allow the access inside the water heaters for maintenance operations, follow the minimum service clearances indicated in figure 5.

To facilitate the installation, the water heater is provided with a jig that allows setting in advance the connections to the tubes providing the ability of connecting the water heaters to completed masonry structure.

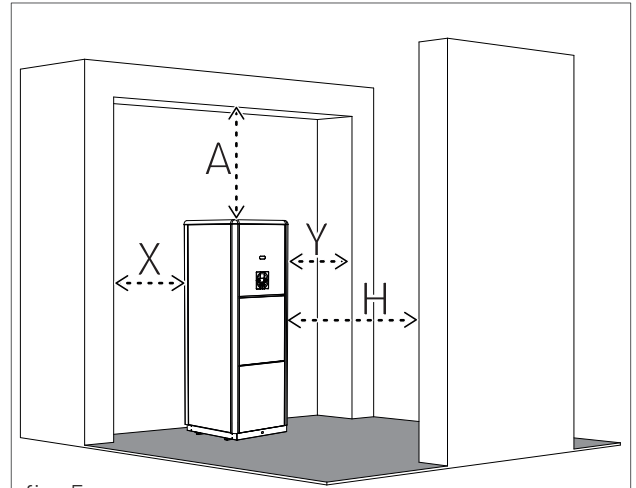

fig. 5

A - 7.8 inch

X - 0 inch-2 inch*

Y - 2 inch-0 inch*

H - 20 inch

*The Quattro requires a minimum of 2" clearance on EITHER ONE OF X or Y for condensate drain clearance to one side of cabinet.



1.1.7. CIRCULATOR PERFORMANCE CURVE

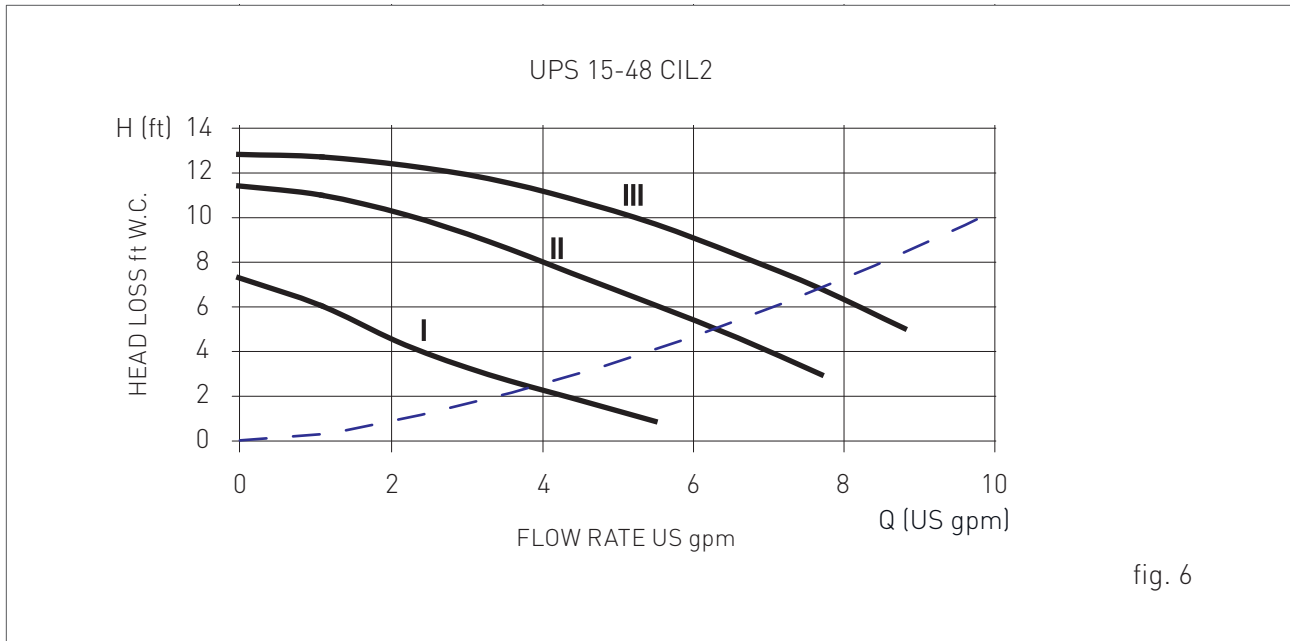

III — Circulator priority maximum speed

II — Circulator priority at second speed

I — Circulator priority at minimum speed

- - - - Appliance Loss



1. INSTALLATION

PROBE FOR THE STORAGE

Electrical nominal resistance at 25 °C 10000 Ohm

B 3435 +/- 1% (25-85)

fig. 7



Temp. °C	R NTC
0	27279
10	17959
20	12090
30	8313
40	5828
50	4161
60	3021
70	2229
80	1669



1.1.8. WATER CONNECTION



DANGER

Make sure that the water tubes are not used as grounding system for the electrical plant. There are not suitable for such use.



WARNING

To prevent voiding the warranty and to ensure the proper operation of the water heaters, please wash the unit (if possible when hot) with suitable descaling solution to remove the impurities coming from tubes.



WARNING

When connecting the equipment to water supply, avoid excessive bending and recovery operations from improper positioning that may damage the tubes causing leaks, malfunction or premature wear.



WARNING

In order to avoid any vibrations and noises, do not use tubes with small diameters or elbows with small radius and significant cut-off of the passage sections.

DOMESTIC CIRCUIT

In order to prevent limestone build-up and damages to the domestic water heat exchanger, the hardness of the domestic supply water should not exceed 15 °dH. However, please check the characteristics of the water used and install suitable treating devices.

The pressure of the cold inlet water should be between 7.2 psi (0.5 bar) and 150 psi (10.34 bar).

In case of greater pressure values, please install a pressure reducer upstream from the water heaters.

The heat exchanger coil cleaning frequency depends on the hardness of the supply water and on the presence of solid residues or impurities inside the water that are often present in recently

installed units. Based on the characteristics of the inlet water, you should install suitable water treatment devices, for residues presence please install an inline filter.

HEATING CIRCUIT



WARNING

Connect the boiler safety drains (heating circuit safety valve) to a discharge funnel. The manufacturer is not responsible for any floods due to safety valve opening in case of unit excessive pressure build up.



WARNING

If a relief valve discharges periodically, this may be due to thermal expansion in a closed water supply system. Contact the water supplier or local plumbing inspector on how to correct this situation. Do not plug the relief valve.



WARNING

In case the water heater is installed as part of a low temperature circuit, please install a safety thermostat on the heating flow, which can stop the water heater activity in case of high heating flow temperature. The company assumes no liability for damage caused to persons or for failure to comply with these instructions.

This water heater is suitable for water (potable) heating and space. Please note the following: **Ü**) The piping and components connected to the water heater for the space heating application shall be suitable for use with potable water; **Ü**) Toxic chemicals, such as used for boiler treatment, shall not be introduced into the potable water used for space heating; **Ü**) A water heater that will be used to supply potable water shall not be connected to any heating system or component(s) previously used with a non-potable water eating appliance; **Ý**) When the system requires water for space heating at temperatures higher than required for other uses, a means such as a mixing valve shall be installed to temper the water for those uses in order to reduce scald hazard potential. Please see the typical piping diagram in the manual; and **Þ**) Water heaters for combination water/space heating cannot be used in space heating applications only.



1. INSTALLATION

1.1.9. PIPING DIAGRAM FOR BASIC INSTALLATION

This is not an engineering drawing. It is intended only as a guide and not as a replacement for professionally engineering project drawings.

This drawing is not intended to describe a complete system. It is up to the contractor / engineer to determine the necessary components and configuration of the particular system being installed.

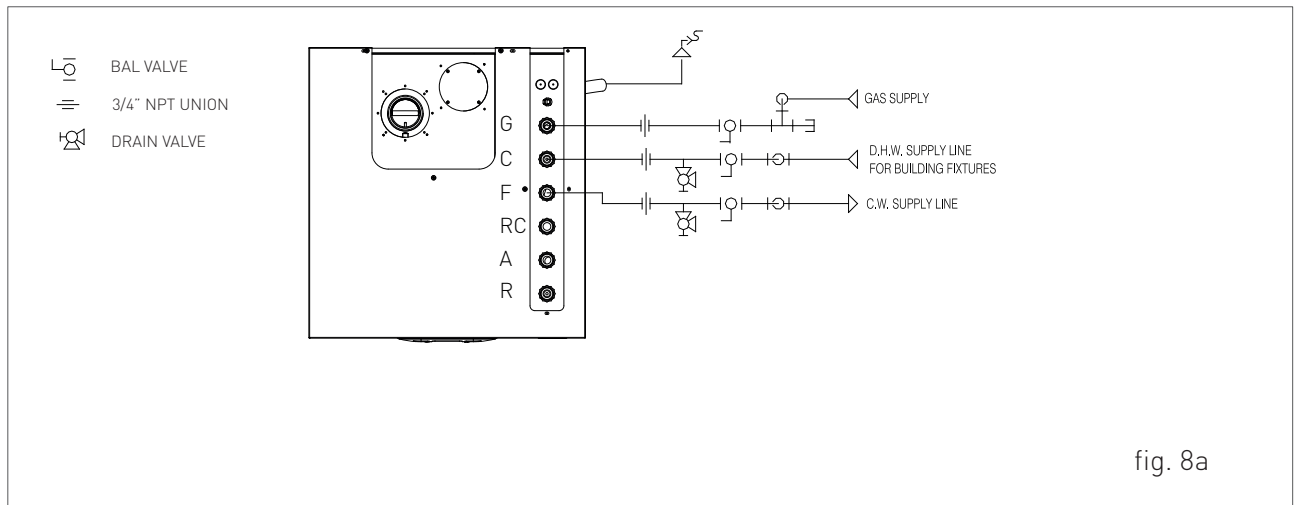

- G GAS
- F DOMESTIC WATER INLET
- C DOMESTIC WATER OUTLET
- RC RECIRCULATION
- A HEATING WATER OUTLET
- R HEATING WATER INLET



1.1.10. PIPING DIAGRAM FOR RECIRCULATION MODE

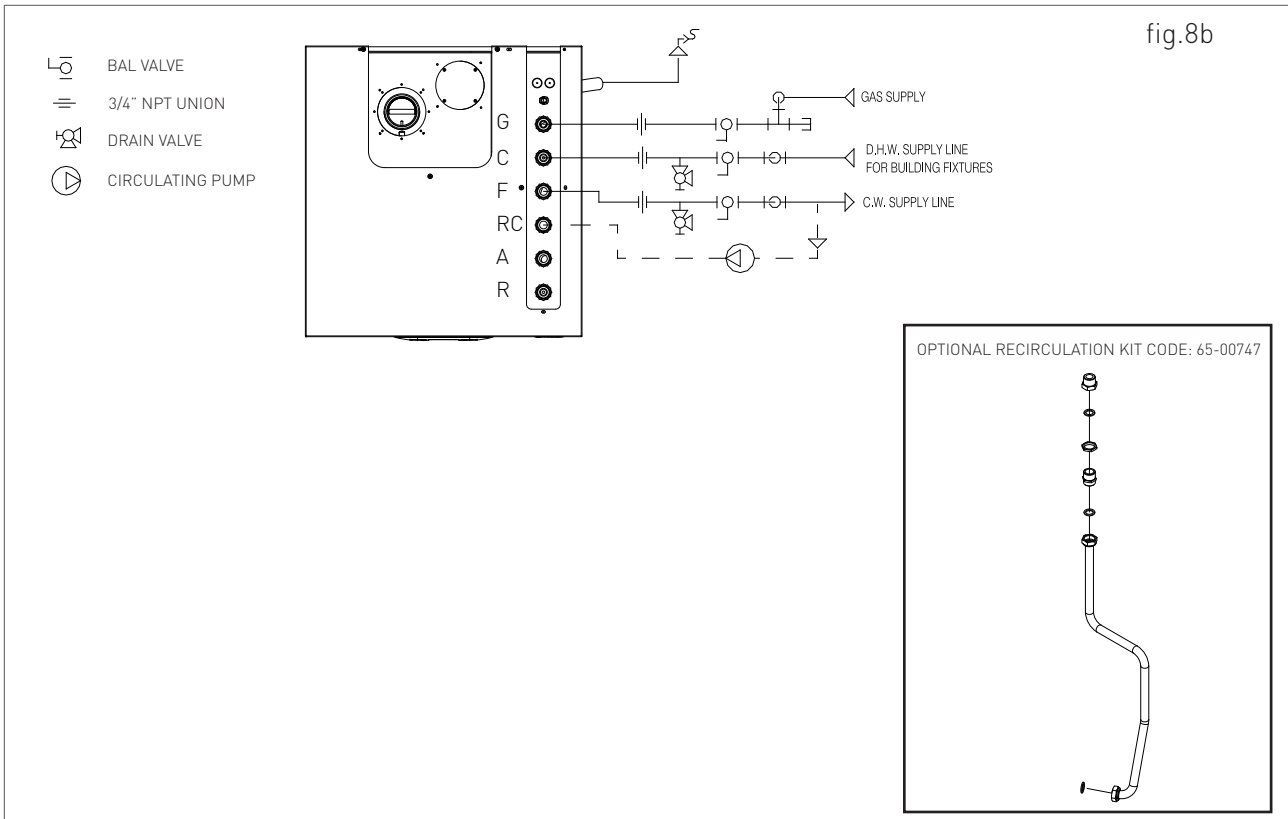

1.1.11. PIPING DIAGRAM FOR COMBINATION MODE (DHW + HEATING)

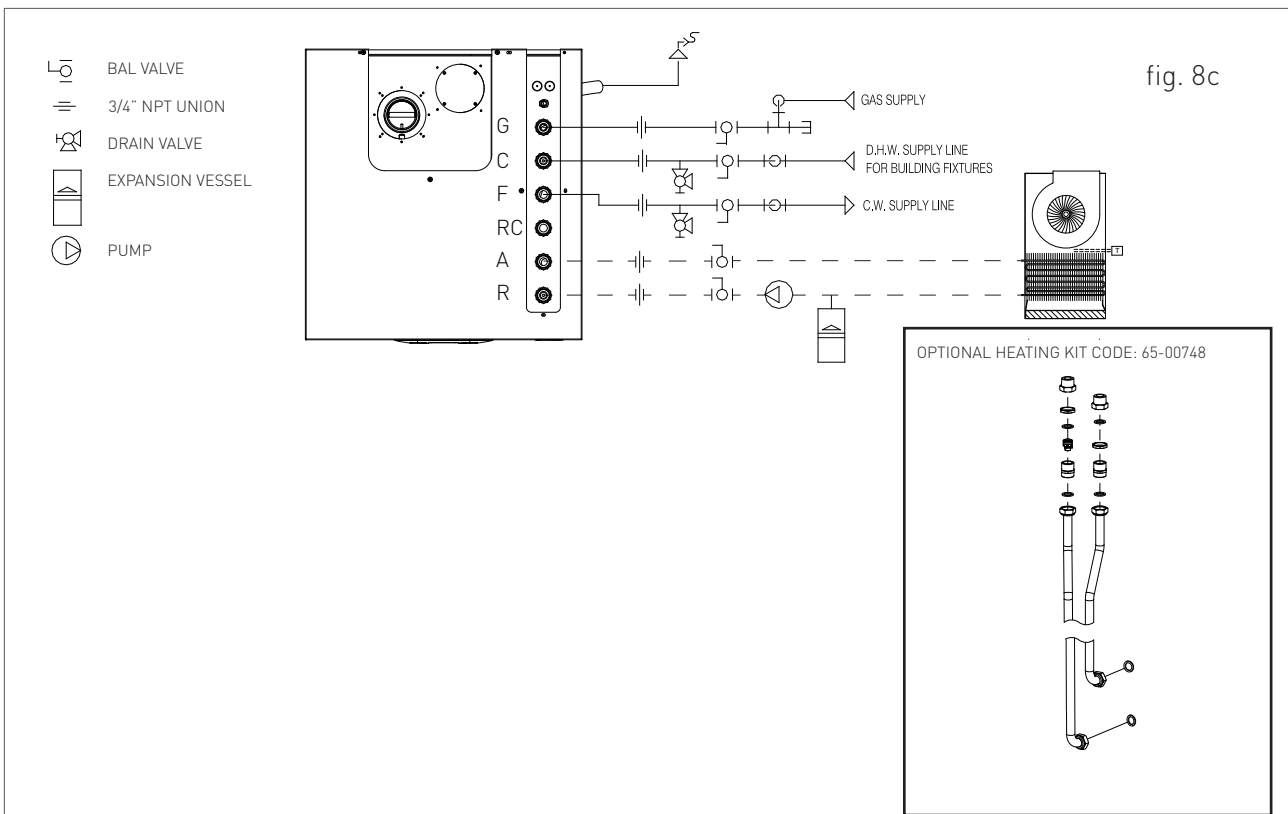



1.1.12. CONDENSATE DRAIN

FILLING THE CONDENSATE COLLECTION SIPON

Before starting the water heaters you have to fill the condensate collection siphon in order to avoid fuel backup through the siphon.

Fill the condensate collection siphon as follows (see fig. 9):

- › Unscrew the “T” cap from the siphon, fill three quarters of the the siphon with water and screw the “T” cap back in;
- › Connect the dedicated flexible condensate drain tube “P” to a waste disposal system.

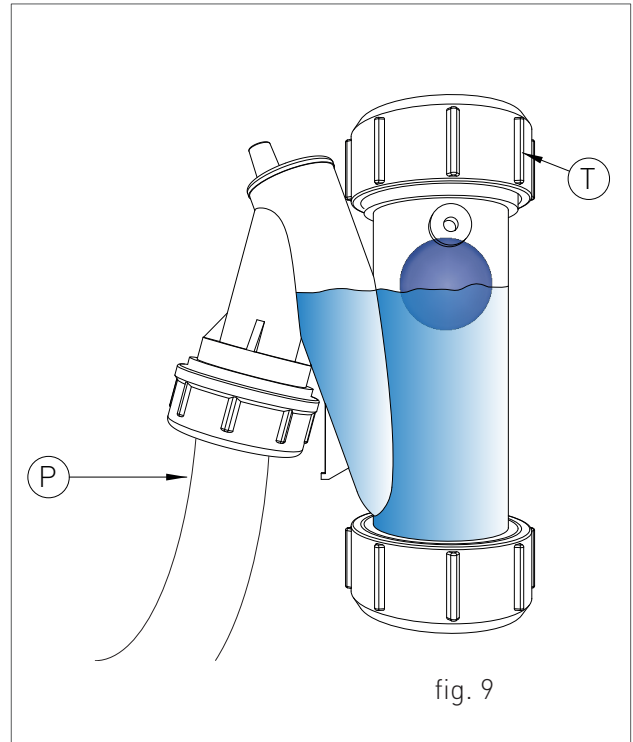

WARNING

After the first months of water heaters operation, it is recommended to clean the condensate trap, to eliminate possible deposits coming from the first flow of the condensate inside the water heaters technical components. These deposits could cause a malfunctioning of the trap.

CONDENSATE DRAIN

The water heaters produces a significant amount of condensate during operation. This condensation has an acidic pH of 3-5. Follow all local codes and regulations when disposing of condensate from the water heaters.

The project engineer should consider the possibility of installing systems to eliminate the acidic condensation, according to system power and buildings' use.

The system should be designed to avoid the condensate freezing. Before the water heaters commissioning, check the correct condensate flow.



WARNING

Check before connecting the condensate trap to the drain pipe, for the proper gradient of water heaters as described in paragraphs “1.1.8 ATTACHING THE WATER HEATERS TO WALL”.



WARNING

Properly connect the siphon condensate from the water heaters to a drain system having adequate slope. Where possible, you should make this connection using transparent tubing to check for proper condensate drainage and avoid stagnation that could cause hazardous backflow of the condensate into the *water heaters*.

To connect the condensate drain use only corrosion-resistant material for the drain line.



CONDENSATE NEUTRALIZER KIT

The condensate neutralization system neutralizes the condensate created by the products of combustion.

Acid condensate, introduced into the neutralization box, follows a two-step set course. First phase: nitrates and sulphates filtration through active carbons contained in the first part of the carbon site pipe. In the second phase the pH rises.

The acidity of the condensate can be controlled through the use of appropriate tools for the determination of Ph, such as the litmus paper. Neutralized condensate can then be routed to the drainage system.

Maintenance

The pH value of the condensate after the neutralizer must be in between $<5,5 - 9,5>$.

Every six months, you need to determine the pH of the condensate treated in the neutralizer. Litmus paper or a digital instrument can be used to measure the pH level.

Neutral point is on the 6,8-7 value; in case of lower value the condensate is acid, in case of a higher value it is basic.

If necessary, replace the active carbon and the reagent granulate.



1.1.13. ANTI-FREEZE PROTECTION

The water heater is protected against freezing using the electronic board design with a function that start the burner and heat the water in the boiler when their water temperature goes below the minimum pre-set values, protecting the water heater up to an external temperature of 14 °F (-10 °C).

The device starts when the hot water temperature goes below 41 °F (5 °C), automatically starting the burner until the water reaches the temperature of 59 °F (15 °C).

The system starts even if display appears "OFF", as long as the water heater is connected to the power (120 V) and gas supply.

For long periods of standby, please empty the water heater and the plant.

If the temperature goes below 14 °F (-10 °C) centigrades, please insert the electrical resistances kit (cod. 82259LP).



1.1.14. GAS CONNECTION



WARNING

The gas piping must be installed according to all local and state codes, or in absence of local and state codes, with the latest "Natural gas and propane installation code", CAN/CSA-B 149.1 or "National Fuel Gas Code", ANSI Z223.1 (NFPA 54). Consult the "Natural gas and propane installation code" or "National Fuel Gas Code" for the recommended gas pipe size of other materials.

BEFORE PERFORMING THE GAS CONNECTION, MAKE SURE THAT:

- › the gas line size and length meets requested capacity;
- › the gas line is equipped with all safety and control devices required by the standards in force;
- › the internal and external seals of the gas inlet lines of the unit are checked;
- › the unit is suitable for use with the type of gas available by checking the water heater data plate (located on the inner side of the front casing. If they do not match you must take the necessary measures to adapt the water heater to another type of gas (see 2.2.17 CONVERSION TO A DIFFERENT GAS TYPE);
- › the gas supply pressure falls within the values indicated on the data plate.
- › The appliance and its individual shutoff valve must be disconnected from the gas supply piping system during any pressure testing of that system at test pressures in excess of ½ psi (3.5 kPa).
- › The appliance must be isolated from the gas supply piping system by closing its individual manual shutoff valve during any pressure testing of the gas supply piping system at test

pressures equal to or less than ½ psi (3.5 kPa).

- › The appliance shall be installed such that the gas ignition system components are protected from water (dripping, spraying, rain etc.) during boiler operation or service (circulators or control replacement etc.). The appliance and its gas connections must be leak tested before placing the the appliance is put into operation. Use a chloride-free soap and water solution (bubbles forming indicate a leak) or other approved method.

1.1.15. ELECTRICAL CONNECTION



DANGER

The equipment is electrically safe only if it is properly connected to an efficient grounding system, performed in compliance with the safety standards in force (National Electrical Code, ANSI/NFPA 70 and or the Canadian Electrical Code Part I, CSA C22.1, Electrical Code). You should check this essential safety requirement. If in doubt, request an accurate check of the electrical system performed by qualified staff, as the manufacturer is not responsible for any damages caused by lack of grounding system.

- › Make sure that the electrical systems is suitable for the maximum power consumed by the equipment, value indicated on the data plate.
- › make sure that the cables section is appropriate for the maximum power consumed by the equipment.
- › The equipment works with alternating current of 120 V and 60 Hz. The electrical connection must be installed using an all-pole switch with an opening of at least 0.12 in (3 mm) between contacts placed upstream from the device.



1. INSTALLATION



WARNING

Make sure that the phase and neutral cables connection is installed in compliance with the wiring diagram (see 1.1.16 POWER SUPPLY).



WARNING

It is strictly forbidden to use adaptors, multiple plugs and/or extensions for the general power supply of the equipment from the electrical supply.



1.1.16. POWER SUPPLY

To power the water heaters connect the electrical cables to the terminal inside the control panel as follows:



DANGER

Shut off the voltage from the main switch.

- › remove the water heaters's front casing (refer to 2.2.13 ACCESSING THE WATER HEATERS).
- › loosen the two screws and remove the plate "A" (see fig. 10).
- › after removing the plate, connect the electrical cables to terminal "B" (see fig. 10):
 - the yellow/green cable to the terminal marked with grounding symbol "⊕".
 - the white cable to the terminal marked with "N".
 - the black cable to the terminal marked with "L".

After performing these operations, remount plate "A" and the front casing.

Note: A 3-prong plug is provided with every unit and the above wiring has been performed.

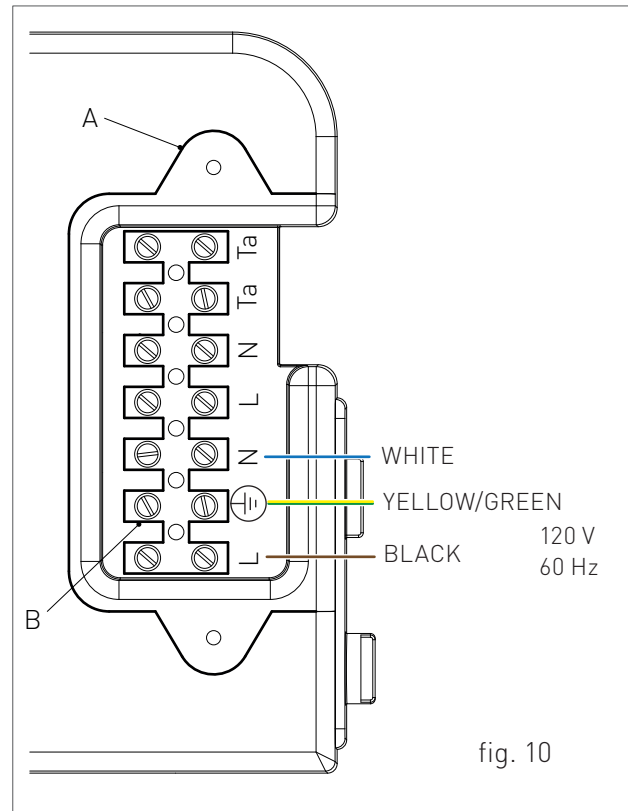

1.1.17. OPTIONAL ELECTRICAL CONNECTIONS

The cables should be inserted inside the water heater using the cable glands 'P1' and 'P2' placed under the board (see fig. 11). Make a hole on the cable gland, smaller than the cable diameter, to make sure that the air cannot pass through.

To wire the options below:

- **(PR) HEATING CIRCULATOR**
- **(TA) ENVIRONMENT THERMOSTAT**
- **(CR) REMOTE CONTROL OPEN THERM COD. 40-00017**

use the terminal placed inside the control panel as follows:



DANGER

Cut off the voltage from the main switch.

- › remove the water heaters's front casing (refer to 2.2.13 ACCESSING THE WATER HEATERS).
- › unscrew the screws and remove plate "A" (see fig. 12).
- › After removing the plate, connect the electrical cables to terminal "B" (see fig. 12):
 - For the heating circulator connect the two conductors to the L - N contacts.
 - For the environment Thermostat or Remote control, first remove the bridge on the Ta-Ta contacts and then connect the two non-polarized conductors to the Ta-Ta contacts.

After performing these operations, remount plate "A" and the front casing.

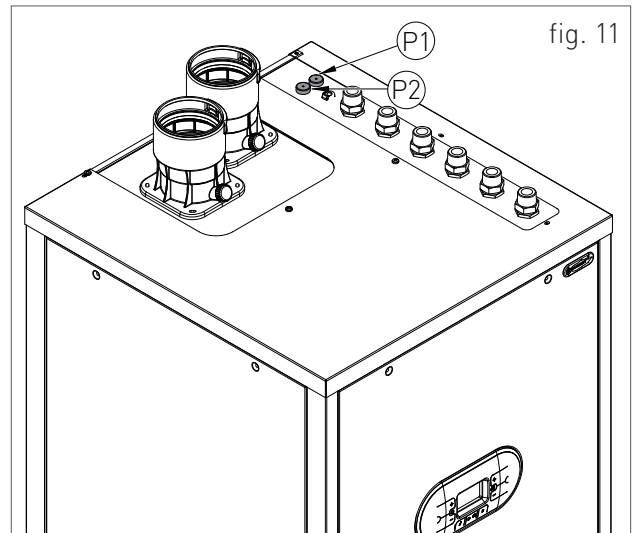

fig. 11

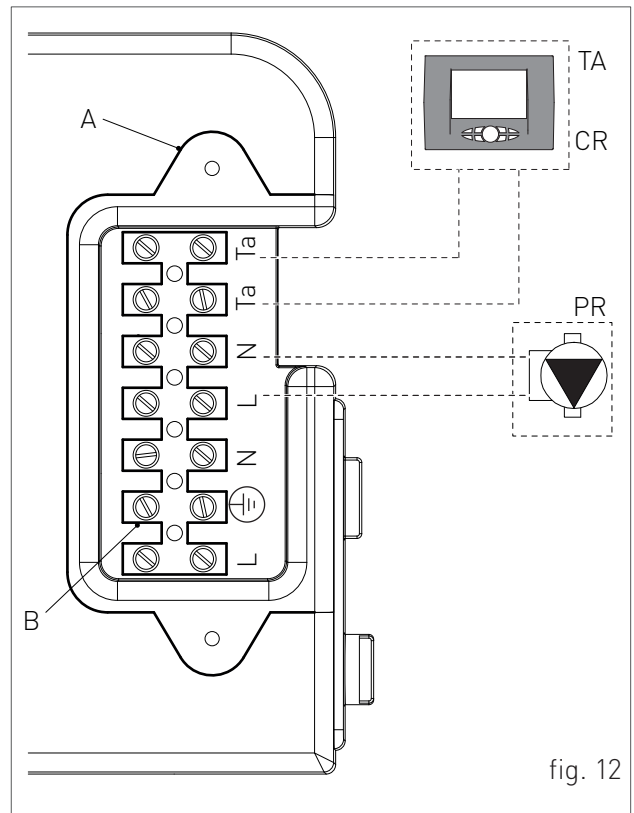



fig. 12

NB: In case of simultaneous presence of external probe and remote control, the modulation board only sends the external temperature value to the remote device without using it for modulation.

The communication between board and remote control takes place independently from the water heaters's operating mode and after establishing the connection, the used interface on the board is disabled and the display shows the symbol .

To wire the options below:

- (TP) DOMESTIC HOT WATER PRE-HEATING DEACTIVATION TIMER

Use the electronic board placed inside the control panel as follows:



DANGER

Shutoff the voltage from the main switch.

- › Remove the water heaters's front casing (refer to 2.2.13 ACCESSING THE WATER HEATERS).
- › Remove the crankcase of the control panel (see 2.2.14 ACCESSING THE ELECTRONIC BOARD).
- › After removing the crankcase, connect the items below to the electronic board (see fig. 13):

After performing these operations, remount the crankcase and the front casing.

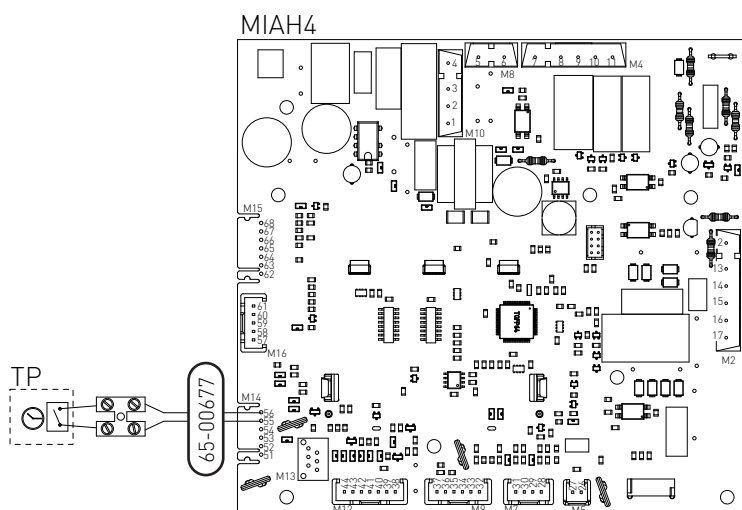

fig. 13



1. INSTALLATION

1.1.18. VENTING



WARNING

In order to ensure proper operation and efficiency of the device you have to connect the water heater fume exhaust fitting to the exhaust and fresh air adapters (loosely supplied in water heaters). It is recommended to install discharge systems approved by Radiant.



WARNING

All termination kits must be located and installed in accordance with local building code and CSA B149.1 Natural Gas and Propane Installation Code.



WARNING

For condensate collection please follow the local codes.

- › All exhaust runs shall be sloped such that any condensate would move towards the combustion chamber so that it can be collected and drained via the internal condensate trap of the appliance (Refer to section 1.1.18).
- › All combustion air intake runs where possible should be sloped in a manner to avoid rain water, dust or foreign objects from entering the appliance (Refer to section 1.1.18).
- › In case of horizontal polypropylene co-axial system installation, properly orientate the horizontal co-axial terminal in relation to the slopes inside the exhaust pipe and to protect the combustion air pipe from adverse weather conditions (Refer to section 1.1.18, sub-section III (a) and figure 20).

This appliance is certified to be installed using polypropylene, PVC and CPVC. For Canada use System 636 polypropylene, PVC and CPVC Type BH Gas Venting Systems certified to ULC S636. Types of venting configurations for this appliance are, co-axial vent (pipe with in a pipe), co-linear vent (separate pipes for exhaust and combustion

air), and single exhaust vent (uses room air for combustion).

This appliance shall not be connected to a chimney flue serving a separate appliance, designed to burn solid fuel.

Use of cellular core PVC (ASTM F891), cellular core CPVC, or Radel® (polyphenylsulfone) in non-metallic venting systems is prohibited.

The vent for this appliance shall not terminate:

- 1) over public walkways; or
- 2) near soffit vents or crawl space vents or other areas where condensate or vapor could create a nuisance or hazard or cause property damage; or
- 3) where condensate vapor could cause damage or could be detrimental to the operation of regulators, relief valves, or other equipment.

Please refer to figure 14 for further clearances on where to terminate the vent.

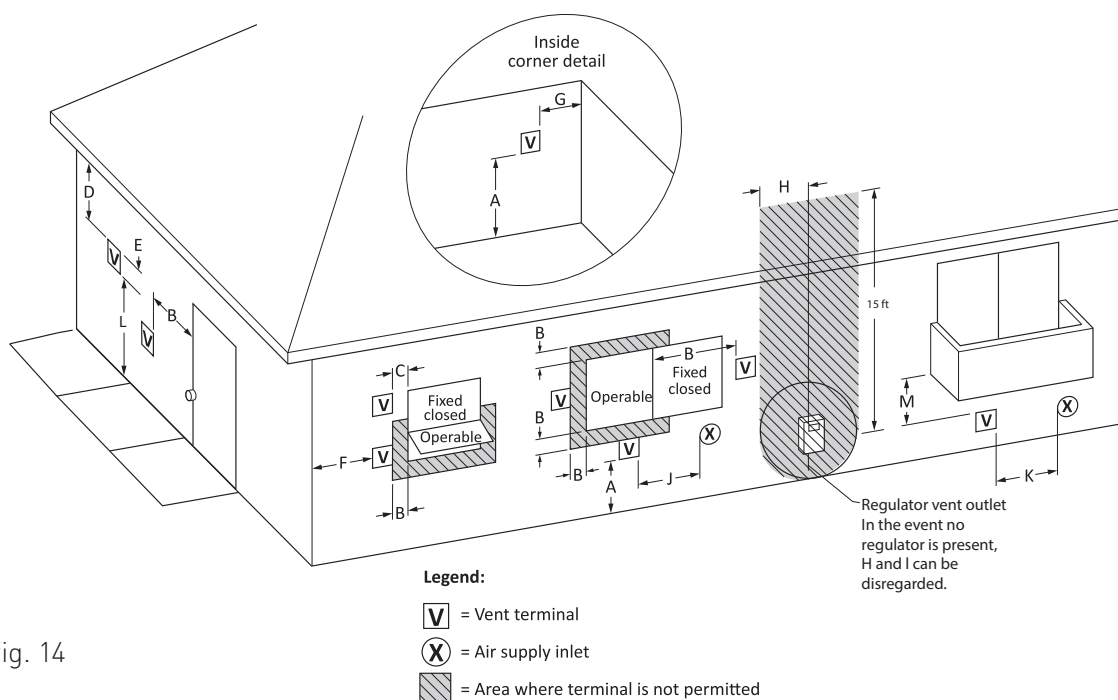

fig. 14

	Canadian installations ¹ .	US installations ² .
A = Clearance above grade, veranda, porch, deck, or balcony	12 in (30 cm)	12 in (30 cm)
B = Clearance to window or door that may be opened	12 in (30 cm)	Non direct vent: 4 ft (1.2 m) below or to side of opening; 1 ft (300 mm) above opening Direct vent: 12 in (30 cm)
C = Clearance to permanently closed window	Zero clearance to permanently closed window. Please consult with local installation codes, the requirements of the local gas supplier and local regulator having jurisdiction for further requirements.	
D = Vertical clearance to ventilated soffit located above the terminal within a horizontal distance of 2 ft (61 cm) from the center line of the terminal.	12 in (30 cm)	12 in (30 cm)



1. INSTALLATION

	Canadian installations ¹	US installations ²
E = Clearance to unventilated soffit	12 in (30 cm)	12 in (30 cm)
F = Clearance to outside corner	Zero Clearance	Zero Clearance
G = Clearance to inside corner	In accordance with the local installation codes and the requirements of the local gas supplier.	
H = Clearance to each side of center line extended above meter/regulator assembly	3 ft (91 cm) within a height 15 ft (4.6 m)	In accordance with the local installation codes and the requirements of the local gas supplier.
I = Clearance to service regulator vent outlet	3 ft (91 cm)	In accordance with the local installation codes and the requirements of the local gas supplier.
J = Clearance to nonmechanical air supply inlet to building or the combustion air inlet to any other appliance	12 in (30 cm)	Non direct vent: 4 ft (1.2 m) below or to side of opening; 1 ft (300 mm) above opening Direct vent: 12 in (30 cm)
K = Clearance to a mechanical air supply inlet	6 ft (1.83 m)	3 ft (91 cm) above if within 10 ft (3 m) horizontally
L = Clearance above paved sidewalk or paved driveway located on public property	7 ft (2.13 m)†	7 ft (2.13 m) †
M = Clearance under veranda, porch deck, or balcony	12 in (30 cm)‡	12 in (30 cm)‡

NOTE:

1. In accordance with the current CAN/CGA-B149 Installation Codes.

2. In accordance with the current ANSI Z223.1-(Latest Edition)/NFPA 54 National Fuel Gas Code.

† A vent shall not terminate directly above a sidewalk or paved driveway that is located between two single family dwellings and serves both dwellings.

‡ Permitted only if veranda, porch, deck, or balcony is fully open on a minimum of two sides beneath the floor.



1.1.19. TYPES OF EXHAUST SYSTEMS

GENERAL INTRODUCTION

The venting installation must conform to the requirements of the authority having jurisdiction or, in the absence of such requirements, to the National Fuel Gas Code, ANSI Z223.1/NFPA 54, and/or Natural Gas and Propane Installation Code, CAN/CSA B149.1.

Horizontal exhaust runs shall slope upwards not less than 1/8 in/ft (10.5mm/m) from the appliance to the vent terminal, although 1/4 in/ft is preferred. Venting shall be installed so as to prevent the accumulation of condensate throughout the vent runs. Provide means for drainage of condensate on all Combustion and Exhaust runs with greater than 5' horizontal or vertical travel per run (excluding elbows and Snorkel Termination) and where necessary.

Horizontal combustion air intake runs should slope downwards not less than 1/4 in/ft [21 mm/m] from the water heater to the air intake terminal where possible.

For installations in which the combustion air run cannot slope to the outdoors, it is recommended that a trap be installed closed to the appliance (see figure 'H').

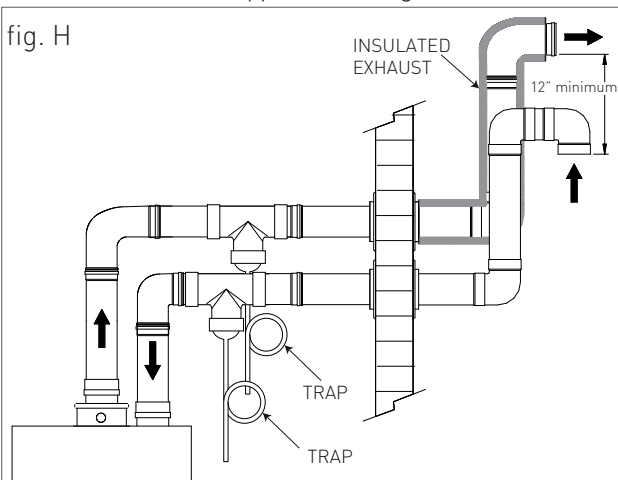

Where not possible a water trap shall be installed so as to collect moisture or water from entering into the air box of the water heater. Provide means for drainage of moisture and water on all vertical air intake runs and where necessary.

Traps, if used, should have pipe slopes not less than 1/4 in/ft [21 mm/m] downwards to the trap.

The use of thermal insulation shall be prohibited on non-metallic vent pipe and fittings in conditioned space. However, for vent runs in unconditioned space where freezing is a concern, a minimum of 1/2" thick Armaflex is recommended.

I - CO-LINEAR VENT (FRESH AIR AND EXHAUST)

The Gas-Fired wall mounted hot water heaters can be installed with two separate pipes. The two separate pipes consists of one for the exhaust an the other for combustion air intake.

Please refer to Table 1: Allowable vent lengths for maximum vent and combustion air intake runs.

Co-linear vent installations can be either be installed through the wall or through the roof.

I (a) - THROUGH THE WALL LNSTALLATION:

Through the wall installations can terminate with two separate pipes or with a concentric terminal.

Please refer to figure 'A' for installations using terminations using co-linear vent.

Refer to figures 'B' and 'C' for installations using co-linear vent with co-axial terminal.

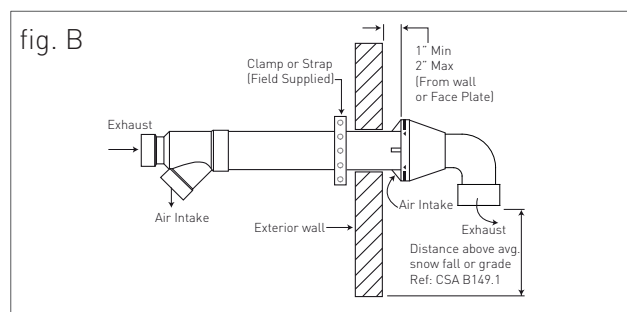
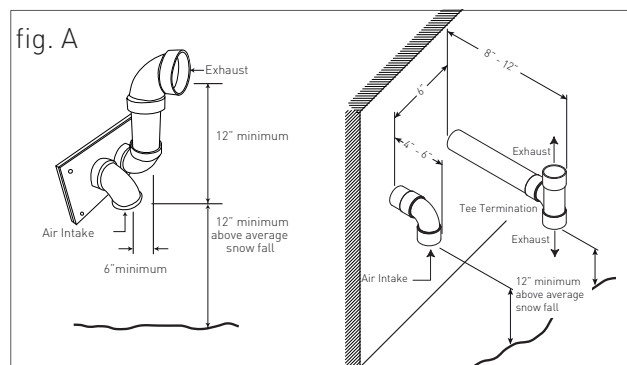



1. INSTALLATION

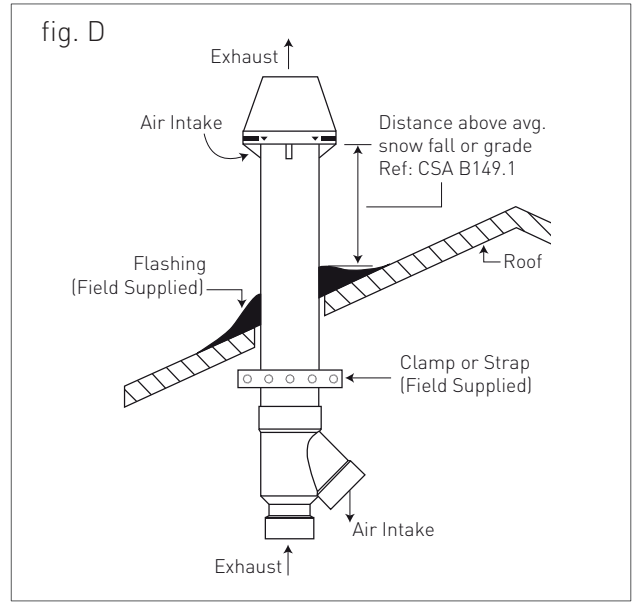
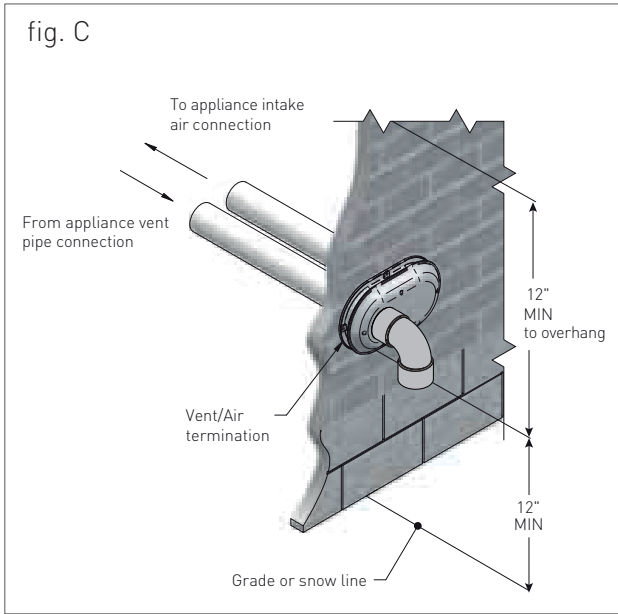

IPEX Low Profile Termination Kits (PVC)*(fig. C)

Size	IPEX	Product Code
2"		19698RAD
3"		196985RAD
4"		196986RAD

*Kits must be purchased via Radiant North America for proper kit.



I (b) - THROUGH THE ROOF LNSTALLATION:

Through the roof installations can terminate with two separate pipes or with a co-axial terminal.

Refer to figure 'D' for installations using a co-linear vent with vertical co-axial terminal.

II - SINGLE VENT

This gas-fired wall mounted hot water heaters can be installed with one single vent pipe for exhaust.

Please refer to Table 1: Allowable vent lengths for maximum vent run.

Single vent installations can be either be installed through the wall or through the roof.





II (a) - THROUGH THE WALL INSTALLATION:

Please refer to figure 'E' for through the wall single vent installations.

II (b) - THROUGH THE ROOF INSTALLATION:

Please refer to figure 'F' for through the roof single vent installations.

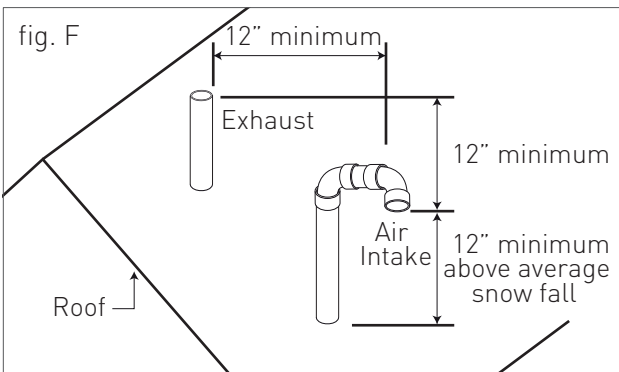
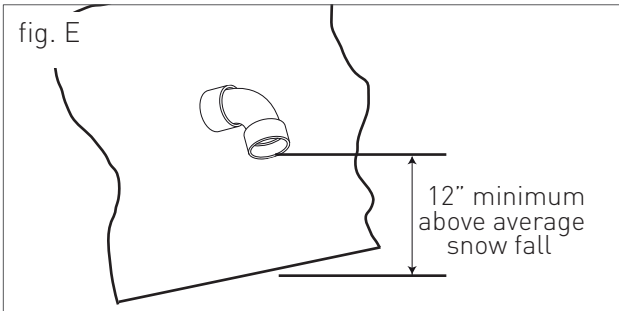



1. INSTALLATION

AIR INTAKE / FLUE EXHAUST Ø 3" (80 MM) ADAPTORS WITH PP TEST POINT (COD.: 65-00433)

These adaptors are to be installed on co-linear vent (two separate pipes for exhaust and combustion air), and single exhaust vent (using room air for combustion). Additional bushings or couplings are required to transition from 3" schedule 40 pipe to 2" or 4" schedule 40 pipe only for installations using 2" or 4" schedule 40 pipe. Additional transition adaptors are not needed for installations using only 60 mm or 80 mm polypropylene, or 3" schedule 40 PVC or CPVC pipe.

Ensure that the adaptors are installed correctly into the correct locations as per the attached figure 15.

Installation instructions:

- Remove the air intake cover plate.
- Clean the inspection collar surface and the area of the air intake hole.
- Stick the appropriate neoprene gaskets onto the underside of the mounting flange of the adaptors. Pay attention to aligning the four mounting through holes.
- Mount the intake/flue exhaust adaptors with self tapping screws provided with the flue kit.
- Install the first piece of 60mm or 80mm polypropylene, 3" schedule 40 PVC or CPVC pipe, or 3" X 2" schedule 40 PVC or CPVC bushing until it bottoms out.
- Finally use the gear clamp to tighten the first piece of either 3" or 2" pipe to the adapter.

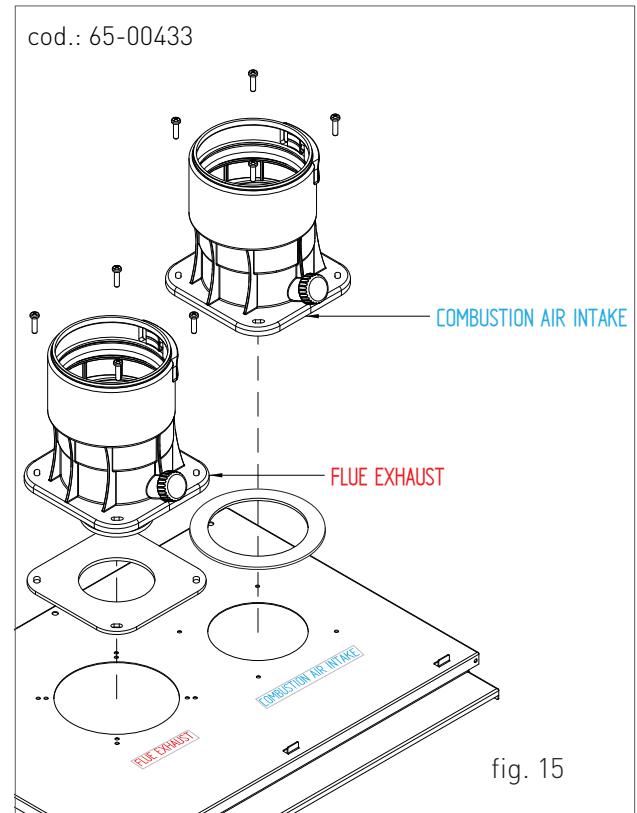



III (a) - KIT M&G HORIZONTAL CO-AXIAL SYSTEM, INTERNAL POLYPROPYLENE DUCT ADJUSTABLE AT 360°.

It allows exhaust and air intake from external wall.

Suitable only for condensing unit.

It allows exhaust and air intake for combustion through co-axial ducts, the external one for air intake, the plastic internal one for exhaust.

PLEASE SEE THE MAXIMUM EXHAUST LENGTH IN THE TABLE IN 1.1.20 "ALLOWABLE VENT LENGTHS".

The maximum exhaust length (or linear reference length) can be calculated by summing the length of the linear tube.

When terminating horizontally, install an elbow at the end of the terminal. For area where snow is a concern it is recommended to point the elbow downwards.

M&G PolyPro Concentric Kits*

Size	Horizontal Product Code
Ø 2.3/3.9 in (Ø 60/100 mm)	2PPC-HKRAD (fig. 16)
Ø 3.1/4.9 in (Ø 80/125 mm)	3PPC-HKRAD (fig. 17)

*Kits must be purchased via Radiant North America for proper kit.

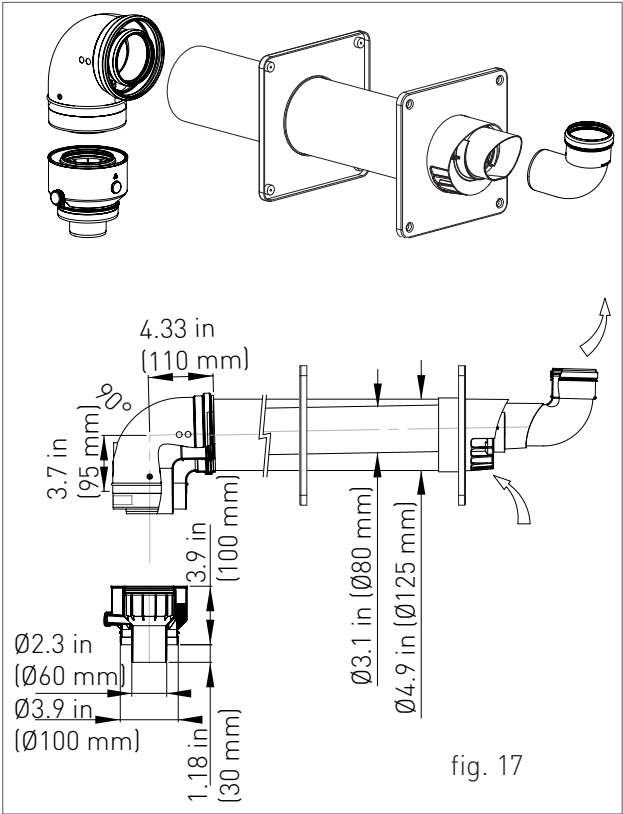
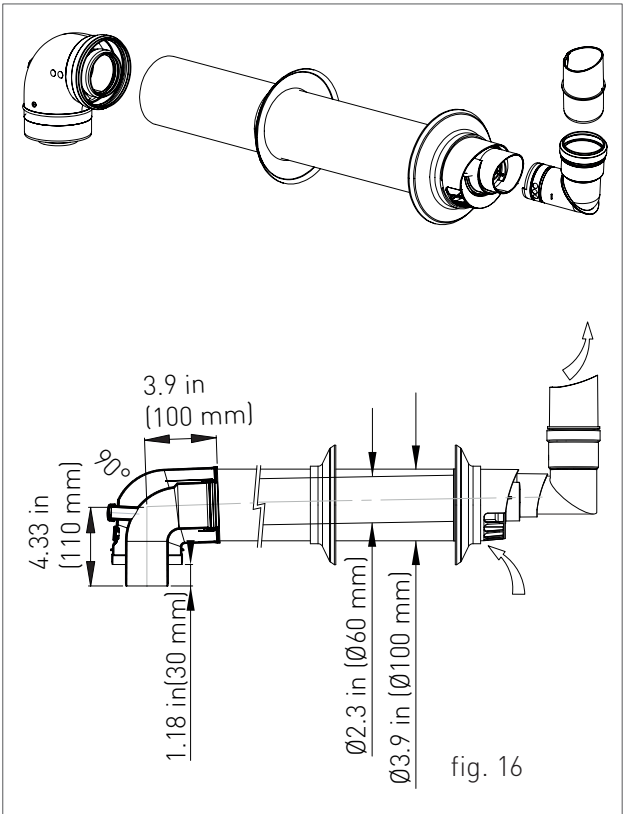



1. INSTALLATION

1.1.20. TABLE 1: ALLOWABLE VENT LENGTHS

Vent Configuration	Pipe Size	Minimum Length Vertical and Horizontal for Vent Run	Max Equivalent length Vertical and Horizontal for vent run	Gas Type	Exhaust Vent	Intake Vent
Co-axial vent	Ø2.3/3.9" (Ø60/100 mm)	1 ft (0.3 m) + elbow	32 ft (10 m) + elbow*	Natural or Propane	Polypropylene	Polypropylene
Co-linear vent (2 Separate pipes)****	2" (60 mm)	3.3 ft (1 m)	100 ft (30 m)**	Natural or Propane	PVC, CPVC, Polypropylene	PVC, CPVC, Polypropylene, ABS
Co-linear vent (2 Separate pipes)****	3" (80 mm)	3.3 ft (1 m)	150 ft (46 m)	Natural or Propane	PVC, CPVC, Polypropylene	PVC, CPVC, Polypropylene, ABS
Single vent	2" (60 mm)	1.6 ft (0.5 m)	36 ft (11 m)***	Natural or Propane	PVC, CPVC, Polypropylene	PVC, CPVC, Polypropylene, ABS
Single vent	3" (80 mm)	1.6 ft (0.5 m)	100 ft (30 m)	Natural or Propane	PVC, CPVC, Polypropylene	PVC, CPVC, Polypropylene, ABS

* The domestic fan maximum speed adjustment (P11) must be changed to a value of 198 Hz and the heating fan maximum speed adjustment (P13) must be changed to a value of 183 Hz with a total vent run of above 10 ft (3 m).

** The domestic fan maximum speed adjustment (P11) must be changed to a value of 198 Hz and the heating fan maximum speed adjustment (P13) must be changed to a value of 183 Hz with a total vent run of above 22 ft (7 m).

*** The domestic fan maximum speed adjustment (P11) must be changed to a value of 198 Hz and the heating fan maximum speed adjustment (P13) must be changed to a value of 183 Hz with a total vent run of above 19 ft (6 m).

**** Vent run consists of allowable vent length for exhaust pipe and an additional allowable vent length for combustible air.

NOTE: In Canada, exhaust vent must be approved to ULC S636 standard.

EQUIVALENT LENGTHS

Each 2"/3" (60 mm / 80 mm) 45° elbow equates to 2.5 linear feet to vent pipe.

Each 2"/3" (60 mm / 80 mm) 90° short radius elbow equates to 7.5 linear feet to vent pipe.

Each 2"/3" (60 mm / 80 mm) 90° long radius elbow equates to 5 linear feet to vent pipe.

Each Ø2.3/3.9" (Ø60/100 mm) co-axial 90° short radius elbow equates to 5 linear feet to vent pipe.

The total maximum equivalent vent pipe distance cannot exceed the maximum length listed for horizontal and vertical venting distance. The maximum lengths are not including elbows unless otherwise stated. Exceeding the maximum venting distances will cause the appliance to malfunction or cause an unsafe condition.



Co-axial Termination (PVC/CPVC ULC S636)*

Size		IPEX Product Code		Royal Plastics Product Code	
Diameter	Length	PVC	CPVC	PVC	CPVC
2" (60 mm)	16 ft (4.8 m)	196005	197040	52CVKGVS6502	
	28 ft (8.5 m)	196105	197033	52CVKGVS6502-28	
	40 ft (12.1 m)	196125		52CVKGVS6502-40	
3" (80 mm)	20 ft (6 m)	196006	197009	52CVKGVS6503	52CVKGVSF9003
	32 ft (9.7 m)	196106	197107	52CVKGVS6503-32	52CVKGVSF9003-32
	44 ft (13.4 m)	196116	197117	52CVKGVS6503-44	52CVKGVSF9003-44
4" (100 mm)	36 ft (10.9 m)	196021	197021	52CVKGVS6504	52CVKGVSF9004-36

*Kits must be purchased via Radiant North America for proper kit.



1. INSTALLATION

Polypropylene venting listed to ULC-S636

Diameter	Length	Brand	Part Number	Description
3/5" (80/125mm)		Z-Dens	2ZDACLC3335	Adaptor Collinear to Concentric
3" (80mm)	12" (305mm)	Z-Dens	2ZDP312	Single Wall Pipe
	24" (305mm)	Z-Dens	2ZDP324	Single Wall Pipe
	36" (305mm)	Z-Dens	2ZDP336	Single Wall Pipe
	72" (305mm)	Z-Dens	2ZDP372	Single Wall Pipe
		Z-Dens	2ZDE345	Single Wall 45° Elbow
		Z-Dens	2ZDE387	Single Wall 87° Elbow
		Z-Dens	3PPS-CDC	Single Wall Condensate Drain
		Z-Dens	3PPS-TCDC	Single Wall Tee w/ Drain Cap
3" (80mm)	12" (305mm)	PolyPro	3PPS-12C	Single Wall Pipe
	36" (305mm)	PolyPro	3PPS-36C	Single Wall Pipe
	72" (305mm)	PolyPro	3PPS-72C	Single Wall Pipe
		PolyPro	3PPS-E45C	Single Wall 45° Elbow
		PolyPro	3PPS-E90C	Single Wall 90° Elbow
		PolyPro	3PPS-CDC	Single Wall Condensate Drain
		PolyPro	3PPS-TCDC	Single Wall Tee w/ Drain Cap



2. SUPPORT CENTRE SECTION

All operations described below relative to first start-up, maintenance and replacement and should be performed only by qualified service technician.



2.1. FIRST START-UP

2.1.1. PRELIMINARY OPERATIONS FOR FIRST START-UP

The first start-up operations consist of checking the correct installation, adjustment and operation of the unit. Proceed as follows:

- › Make sure all water lines connected to the water heater have been thoroughly flushed prior to first used. It is critical that all installation/construction debris has been removed from the system before firing the water heater for the first time.
- › Check the inner component and ensure that they are sealed in accordance with the specifications provided by standard and regulations;
- › check if the gas used is suitable for the water heaters;
- › check if the gas capacity and relative pressures comply with those on the rating plate;
- › check the operation of the safety device in case of lack of gas;
- › make sure that the unit supply voltage corresponds with that on the plate (120 V – 60 Hz) and that the wiring is correct;
- › make sure that the grounding system works properly;
- › make sure that the combustion air circulation, exhaust and condensate discharge take place properly in compliance with the Local and National Laws and Standards in force;
- › make sure that the venting and their connections comply with the requirements of the Local and National Laws and Standards;
- › make sure that the D.H.W. system gate valves are open;
- › make sure that there is no intake of gaseous products within the system;
- › make sure that there are no flammable liquids or materials near the unit;
- › open the water heaters gas tap and make sure that there are no gas leaks upstream from the unit (the burner gas connection must be checked while the machine is running);
- › in case of new installation of the gas supply network, the air inside the tubes may block the unit at first start-up. Repeat the start-up procedure to purge all the air inside the tube.



2.1.2. WATER HEATERS COMMISSIONING

Proceed with water heaters commissioning as follows:

- › Power the water heaters.
- › Open the gas valve.
- › Ignite the unit by pressing the button 
- › Open the D.H.W. taps at the maximum flow rate. The unit is ignited.
- › Enter the Info menu, as described in the Chapter 'INFO MENU DISPLAY DATA', and display the value 'd1' - HOT WATER CAPACITY.



WARNING

Please make sure all the air is flushed-off by means of the drain valve located within the unit (A - figure 18).

- › Also make sure that the air eliminator above the pump is loose and that the pump is turning.
- › Should overheating occur or the gas supply fails to shut off, turn the manual gas control valve to the appliance.
- › if the flame is not sensed the board will repeat the start-up operations after post-ventilation (20 seconds).
- › You might have to repeat the start-up operation several times to release all air inside the gas lines. Before repeating the operation, wait at least 5 seconds from the last start-up attempt and unlock the water heater from "E01" error code by pressing the Reset  key.

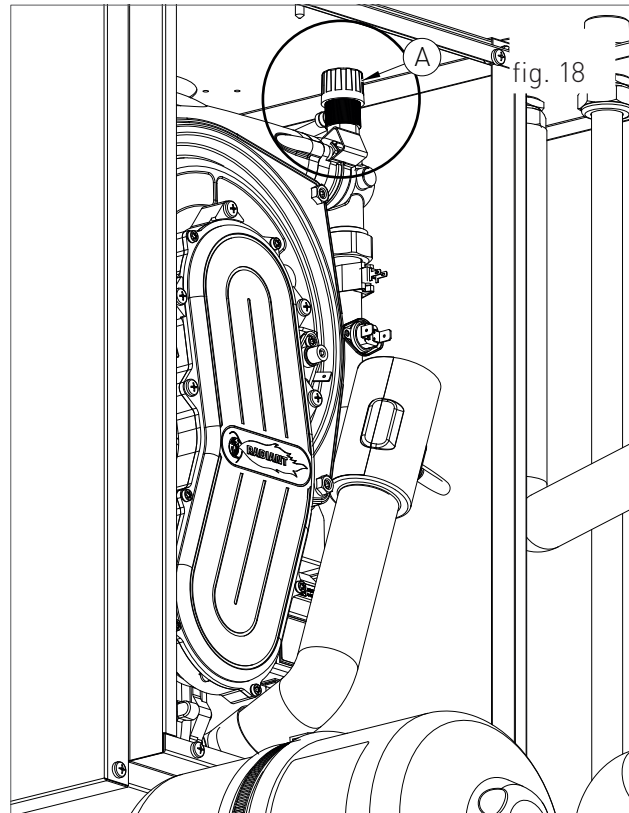

2.1.3. CO₂ VALUE CHECK AND CALIBRATION



WARNING

The CO₂ value should be measured with the casing assembled, while the gas valve could only be adjusted with the casing open.

To check and calibrate the CO₂ value to minimum and maximum power proceed as follows:

FOR MINIMUM POWER

- › Access parameter 'P06' following the procedure described in 2.1.4 "Parameters accessing and programming" and stay in edit mode until the calibration is completed (the maximum time before forced to exit the edit mode is 7 minutes).
- › Open several D.H.W. taps at the highest flow rate.
- › Insert the combustion analyser probe in the suitable 'PF' exhaust tap (fig. 19), then make sure that the CO₂ value complies with the indications in 2.2.8 "Technical data", otherwise unscrew the protection screw 'A' (fig. 20) and adjust using a 4 Allen wrench the screw '2' (fig. 20) of the Off-Set adjuster. To increase the CO₂ value, turn the screw clockwise and counter-clockwise if you want to decrease it.
- › Once the adjustment has been completed, tighten the protection screw 'A' (fig. 20) on the Off-Set adjuster.
- › Exit parameter 'P06' following the procedure described in 2.1.4 "Parameters accessing and programming".

FOR MAXIMUM POWER

- › Open several D.H.W. taps at the highest flow rate.

- › Access parameter 'P07' following the procedure described in 2.1.4 "Parameters accessing and programming" and stay in edit mode.
- › Insert the combustion analyser probe in the suitable 'PF' exhaust tap (fig. 19), then make sure that the CO₂ value complies with the requirements indicated in 2.2.8 "Technical data", otherwise adjust using screw '1' (fig. 20) of the gas flow adjuster. To increase the CO₂ value, turn the screw counter-clockwise and clockwise if you want to decrease it.
- › After each adjustment variation on screw '1' (fig. 20) of the gas flow adjuster you have to wait for the water heater to stabilize itself to the set value (about 30 seconds).
- › Enter again the parameter P06 and make sure that the CO₂ value did not change to maximum, if changed repeat the calibration described in the previous paragraph.

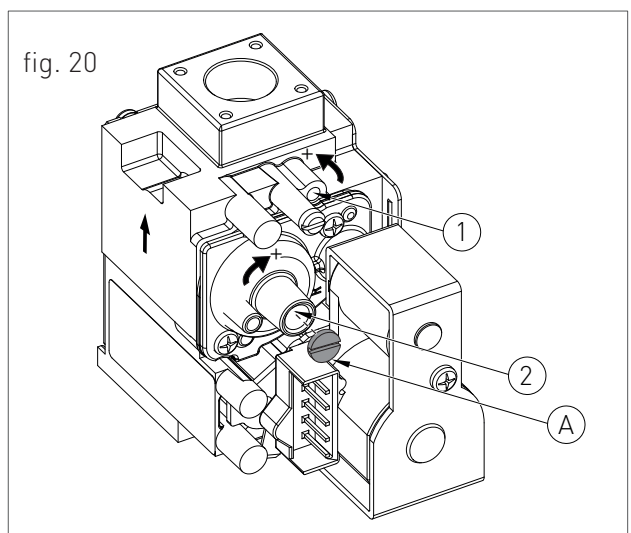
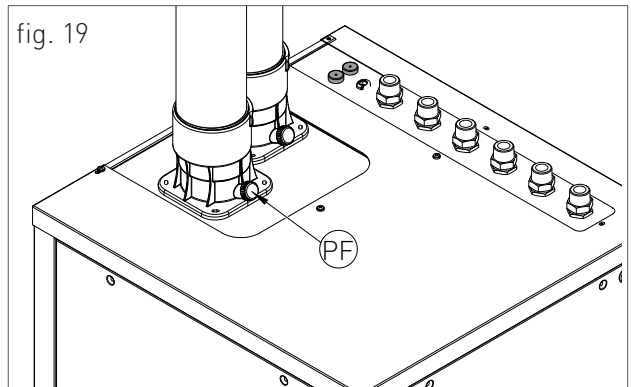

2.1.4. ACCESSING AND PROGRAMMING THE PARAMETERS

To access the parameters menu and adjust their values, follow the procedure below:

1. Press the button  to select the OFF mode displayed using the symbol .

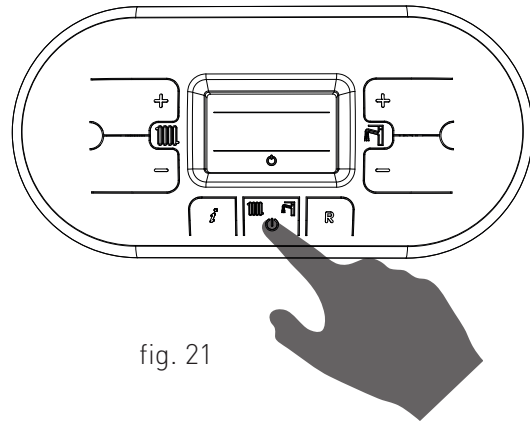







fig. 21

2. Hold at the same time the keys  and  until on the display appears the symbol  with the message 'P00', and release the keys  and .

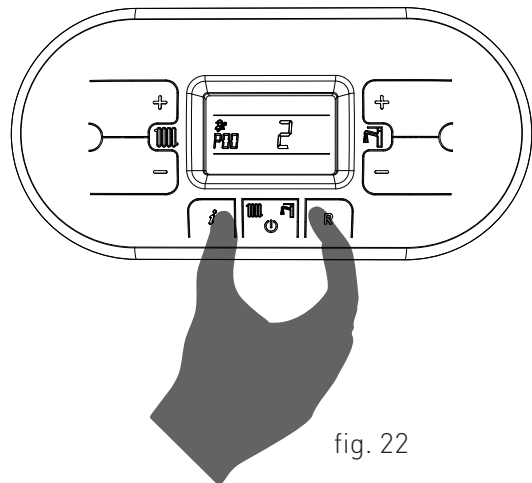

fig. 22

3. Use the keys  and  of the heating circuit  to select the parameter to be edited.

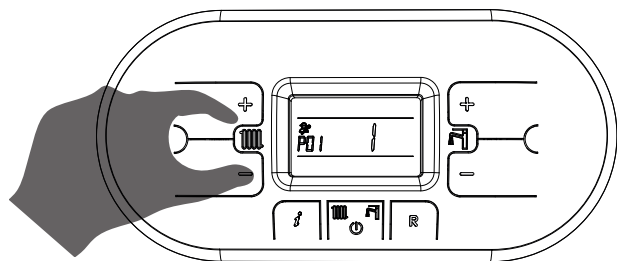

fig. 23

4. Use the keys '+' and '-' of the domestic circuit  to change the value of the parameter.

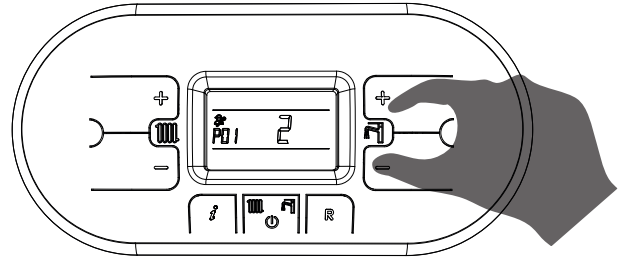



fig. 24

5. Press the key  to confirm the action and wait for the display to stop blinking, indicating the adjustment was implemented.

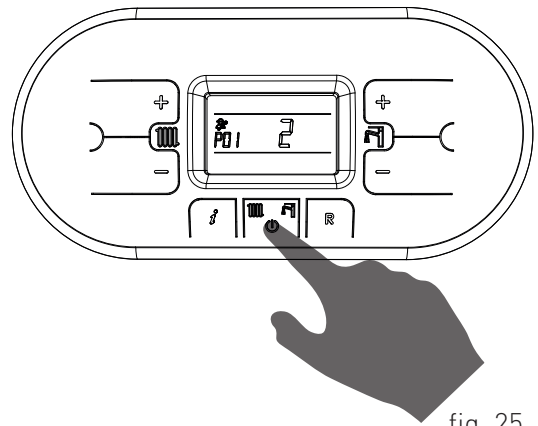





fig. 25

6. To exit the parameters menu, hold at the same time the keys  and  and wait for the symbol  to appear on the display.

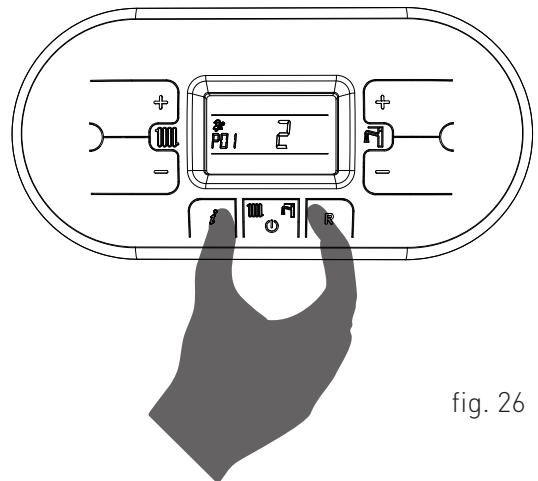

fig. 26



2.1.5. PARAMETERS TABLE

PARAMETER	DESCRIPTION	RANGE	FUNCTION
P00	SELECTION OF THE FIRE RATING	0 - 3	0 = 24 KW 1 = 28 KW (SFK 57) 2 = 34 KW 3 = 55 KW (SFK 55 - SFK 56)
P01	GAS TYPE SELECTION ATTENTION: READ THE INSTRUCTION IN CHAPTER 'GAS TRANSFORMATION' BEFORE CHANGING THIS PARAMETER.	0 - 1	0 = NATURAL GAS 1 = LPG
P02	OPERATION MODE SELECTION ATTENTION: IF THE PARAMETER VALUE IS SET TO '2' MAKE SURE THAT THE THREE-WAY VALVE IS TURNED IN THE RECIRCULATION POSITION, AS DESCRIBED IN THE CHAPTER 'RECIRCULATION IN COMBINATION MODE'.	0 - 3	0 = WATER HEATER 1 = WATER HEATER WITH INDIRECT TANK 2 = COMBINATION MODE (DHW + HEATING) - SFK 56 3 = COMBINATION MODE (DHW + HEATING) WITH TANK - SFK 57 4 = N.A.
P03	POST-CIRCULATION TIMING (RECIRCULATION MODE NON ACTIVE) THROUGH THIS PARAMETER YOU CAN SET THE PUMP OPERATION DURATION ON THE DOMESTIC CIRCUIT, AFTER THE TAP IS CLOSED.	0 - 90	VALUE EXPRESSED IN MULTIPLES OF 5 SECONDS (FACTORY SET AT 12 X 5 = 60 SECONDS)
P04	POST-CIRCULATION TIMING (RECIRCULATION MODE ACTIVE) THROUGH THIS PARAMETER YOU CAN SET THE PUMP OPERATION DURATION ON THE DOMESTIC CIRCUIT, WHEN THE RECIRCULATION MODE IS ACTIVE, AFTER THE TAP IS CLOSED.	0 - 90	VALUE EXPRESSED IN MULTIPLES OF 5 SECONDS (FACTORY SET AT 8 X 5 = 40 SECONDS)



2. FIRST START-UP

PARAMETER	DESCRIPTION	RANGE	FUNCTION
P05	<p>RECIRCULATION DIFFERENTIAL ACTIVATION</p> <p>THROUGH THIS PARAMETER YOU CAN ANTICIPATE THE RECIRCULATION FUNCTION, COMPARED TO THE RECIRCULATION SET POINT PRESET BY THE END-USER, BY MODIFYING THE TEMPERATURE DIFFERENCE.</p>	5 - 15	VALUE EXPRESSED IN °C
P06	<p>FAN MINIMUM SPEED ADJUSTMENT</p> <p>THROUGH THIS PARAMETER YOU CAN SET THE FAN MINIMUM SPEED CORRESPONDING TO THE MINIMUM POWER OF THE BURNER.</p> <p>THE VALUE IS PRE-SET BASED ON THE SET POWER (SEE PARAMETER P00) AND ON THE GAS TYPE (SEE PARAMETER P01).</p>	43 - 255	VALUE EXPRESSED IN HERTZ (1HZ = 30 RPM)
P07	<p>FAN MAXIMUM SPEED ADJUSTMENT</p> <p>THROUGH THIS PARAMETER YOU CAN SET THE MAXIMUM FAN SPEED CORRESPONDING TO THE MAXIMUM POWER OF THE BURNER.</p> <p>THE VALUE IS PRE-SET BASED ON THE SET POWER (SEE PARAMETER P00) AND ON THE GAS TYPE (SEE PARAMETER P01).</p>	43 - 270	VALUE EXPRESSED IN HERTZ (1HZ = 30 RPM)
P08	<p>STARTING STEP ADJUSTMENT</p> <p>THROUGH THIS PARAMETER YOU CAN SET THE FAN SPEED DURING THE START-UP.</p> <p>THE VALUE IS PRE-SET BASED ON THE SET POWER (SEE PARAMETER P00) AND ON THE GAS TYPE (SEE PARAMETER P01).</p>	43 - 255	VALUE EXPRESSED IN HERTZ (1HZ = 30 RPM)
P09	<p>D.H.W RUN-DOWN</p> <p>THROUGH THIS PARAMETER YOU CAN SET THE TIME NECESSARY FOR THE WATER HEATER TO REACH THE MINIMUM SET POWER, AFTER THE BURNER START-UP.</p>	2 - 15	VALUE EXPRESSED IN SECONDS (FACTORY SET AT 8 SECONDS)
P10	<p>TYPE OF UNIT SELECTION</p>	0 - 1	<p>0 = °C - L/MIN</p> <hr/> <p>1 = °F - GPM</p>
P11	<p>EXECUTION PERIOD OF THE OVERHEATING FUNCTION</p> <p>THROUGH THIS PARAMETER YOU CAN ENABLE AND SET THE DURATION OF THE EXECUTION PERIOD OF THE OVERHEATING FUNCTION, DURING WHICH THE CIRCULATING PUMP ACTIVATES BY DISSIPATING THE HEAT IN EXCESS.</p>	0 - 60	VALUE EXPRESSED IN SECONDS (FACTORY SET AT 10 SECONDS)



PARAMETER	DESCRIPTION	RANGE	FUNCTION
P12	ACTIVATION PERIOD OF THE OVERHEATING FUNCTION THROUGH THIS PARAMETER YOU CAN SET THE TIME INTERVAL FROM THE END OF THE POST-CIRCULATION TO THE ACTIVATION OF THE OVERHEATING FUNCTION.	1 - 20	VALUE EXPRESSED IN MINUTES (FACTORY SET AT 10 MINUTES)
P13	MAXIMUM DOMESTIC SETPOINT THROUGH THIS PARAMETER YOU CAN SET THE USER-ADJUSTABLE MAXIMUM DOMESTIC TEMPERATURE.	122 - 152 (50 - 67 °C)	VALUE EXPRESSED IN °F
P14	MINIMUM DOMESTIC SETPOINT THROUGH THIS PARAMETER YOU CAN SET THE USER-ADJUSTABLE MINIMUM DOMESTIC TEMPERATURE.	100 - 113 (35 - 45 °C)	VALUE EXPRESSED IN °F (FACTORY SET AT 104°F [40°C])
P15	ANTI-LEGIONELLA FUNCTION (FOR STORAGE TANK) THROUGH THIS PARAMETER YOU CAN ACTIVATE/DEACTIVATE THE "ANTILEGIONELLA" HEAT TREATMENT OF THE STORAGE TANK. EVERY 7 DAYS THE WATER TEMPERATURE INSIDE THE STORAGE IS HEATED BEYOND 60 °C THUS GENERATING A BURNING HAZARD. KEEP UNDER CONTROL SUCH DOMESTIC HOT WATER TREATMENT (AND INFORM THE USERS) TO AVOID UNFORSEEABLE DAMAGES TO PERSONS, ANIMALS AND PROPERTY. A THERMOSTATIC VALVE SHOULD BE INSTALLED AT THE DOMESTIC HOT WATER OUTLET TO AVOID ANY BURNS.	0 - 1	0 = DISABLED 1 = ENABLED
P16	DIFFERENTIAL OF THE STORAGE TANK CYCLE ACTIVATION THROUGH THIS PARAMETER YOU CAN ANTICIPATE THE PRE-HEATING FUNCTION OF THE STORAGE TANK, COMPARED TO THE D.H.W SET POINT PRE-SET BY THE END-USER, BY MODIFYING THE TEMPERATURE DIFFERENCE.	1 - 20	VALUE EXPRESSED IN °C (FACTORY SET AT 5°C)
P17	MINIMUM D.H.W FLOW RATE SETTING THROUGH THIS PARAMETER YOU CAN SET THE MINIMUM D.H.W. FLOW RATE NECESSARY TO ACTIVATE THE WATER HEATER. THE VALUE IS PRE-SET BASED ON THE SET POWER (SEE PARAMETER P00).	20 - 68	VALUE EXPRESSED IN HERTZ (FACTORY SET AT 30 HZ = 0.55 GPM [2.1 L/MIN])
P18	ADDITIONAL POST-VENTILATION TIMING THROUGH THIS PARAMETER YOU CAN SET A PERIOD OF OPERATION, ADDITIONAL TO THE 20 STANDARD SECONDS OF THE FAN, AFTER THE BURNER SHUTDOWN.	20 - 120	VALUE EXPRESSED IN SECONDS (FACTORY SET AT 30 SECONDS)



2. FIRST START-UP

PARAMETER	DESCRIPTION	RANGE	FUNCTION
P19	ANTI-WATER HAMMER SELECTION ONCE THIS FUNCTION IS ENABLED, THE D.H.W CONTACT WILL BE DELAYED FOR A TIME EQUAL TO THE SET VALUE.	0 - 20	0 = DISABLED (FACTORY SET AT 0') 1-20 = VALUE EXPRESSED IN SECONDS
P20	DESTINATION COUNTRY SELECTION BY MODIFYING THIS PARAMETER THE COMBUSTION CONTROL PARAMETERS WILL BE AUTOMATICALLY CONFIGURATED, ACCORDING TO THE VALUES FIXED IN THE DESTINATION COUNTRY OF THE PRODUCT.	0 - 1	0 = U.S.A. / CANADA 1 = DIFFERENT COUNTRY
P21	PUMP OPERATION IN WATER HEATER MODE THROUGH THIS PARAMETER YOU CAN ACTIVATE/DEACTIVATE THE CIRCULATING PUMP DURING THE NORMAL OPERATION OF THE WATER HEATER.	0 - 1	0 = DISABLED 1 = ENABLED
P22	ENABLING BUS INDUSTRIAL PILOTING 0 -10V THROUGH THIS PARAMETER YOU CAN ENABLE OR DISABLE THE BUS INDUSTRIAL INPUT 0-10 V TO SET THROUGH EXTERNAL BUS THE BURNER POWER OR THE DELIVERY TEMPERATURE.	0 - 2	0 = DISABLED (SET BY DEFAULT) 1 = TEMPERATURE CONTROL MODE 2 = POWER CONTROL MODE
P23	HEATING FAN MINIMUM SPEED ADJUSTMENT THROUGH THIS PARAMETER YOU CAN SET THE FAN MINIMUM SPEED IN HEATING PHASE, THAT CORRESPONDS TO THE MINIMUM BURNER POWER DURING A REQUEST TO OPERATE IN HEATING MODE. [SEE CHAPTER 'COMBUSTION BLOWER FREQUENCY/HEAT CAPACITY DIAGRAM']. THE VALUE IS PRE-SET BASED ON THE SET POWER (SEE PARAMETER P00) AND ON THE GAS TYPE (SEE PARAMETER P01).	45 - VALUE SET FOR PARAMETER P24	THE VALUE IS EXPRESSED IN HERTZ (1HZ = 30 RPM)



PARAMETER	DESCRIPTION	RANGE	FUNCTION
P24	<p>HEATING FAN MAXIMUM SPEED ADJUSTMENT</p> <p>THROUGH THIS PARAMETER YOU CAN SET THE FAN MAXIMUM SPEED IN HEATING PHASE, THAT CORRESPONDS TO THE MAXIMUM BURNER POWER DURING A REQUEST TO OPERATE IN HEATING MODE [SEE CHAPTER 'COMBUSTION BLOWER FREQUENCY/HEAT CAPACITY DIAGRAM'].</p> <p>THE VALUE IS PRE-SET BASED ON THE SET POWER (SEE PARAMETER P00) AND ON THE GAS TYPE (SEE PARAMETER P01).</p>	<p>VALUE SET FOR PARAMETER P23 - 203</p>	<p>THE VALUE IS EXPRESSED IN HERTZ (1HZ = 30 RPM)</p>

P25	<p>CLIMATE COMPENSATION CURVE</p> <p>(NOT APPLICABLE TO THE SFK 57 MODEL)(ONLY WITH EXTERNAL PROBE CONNECTED)</p> <p>YOU CAN CONNECT AN EXTERNAL TEMPERATURE PROBE (SEE CHAPTER 'ELECTRICAL CONNECTIONS') THAT AUTOMATICALLY CHANGES THE DELIVERY TEMPERATURE BASED ON THE EXTERNAL MEASURED TEMPERATURE. THE NATURE OF THE CORRECTION DEPENDS ON THE THERMO-ADJUSTMENT VALUE KD SET (SEE CHART).</p> <p>THE SELECTION OF THE CURVE IS DETERMINED BY THE MAXIMUM DELIVERY TEMPERATURE T_m AND THE MINIMUM EXTERNAL TEMPERATURE T_e TAKING INTO ACCOUNT THE HOUSE INSULATION DEGREE.</p> <p>THE VALUES OF THE DELIVERY TEMPERATURES T_m, REFER TO STANDARD SYSTEMS 86-167 °F (30-75 °C) OR FLOOR SYSTEMS 77-113 °F (25-45 °C). THE SYSTEM TYPE CAN BE SET FROM PARAMETER P30.</p>	<p>0 - 30</p>	<p>(SET BY DEFAULT AT 15) THE NUMBERING OF THE VALUE CORRESPONDS TO 'KD' CURVES ON THE CHART (SEE CHART BELOW).</p>
-----	---	---------------	---

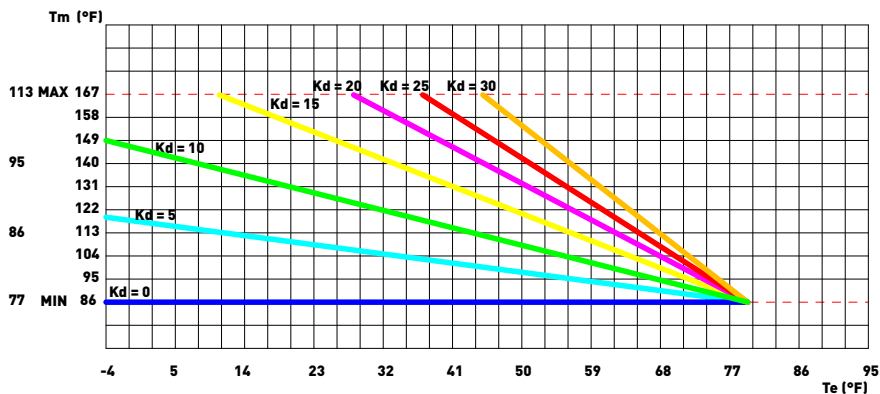

fig. 27



2. FIRST START-UP

PARAMETER	DESCRIPTION	RANGE	FUNCTION
P26	<p>MODBUS ADDRESS</p> <p>BY MEANS OF THIS PARAMETER, IT IS POSSIBLE TO SET THE ADDRESS OF THE BOARD ON MODBUS IN ORDER TO PERFORM A CASCADE SYSTEM.</p>	1 - 16	<p>BOILER NUMBERING FOR MODBUS (FACTORY SET AT 1)</p>
P27	<p>MODBUS COMMUNICATION BAUD RATE</p> <p>BY MEANS OF THIS PARAMETER, IT IS POSSIBLE TO SELECT THE MODBUS COMMUNICATION BAUD RATE SUPPORTED BY THE SAME INTERFACE.</p>	0 - 5	<p>0 = 9600</p> <hr/> <p>1 = 1200</p> <hr/> <p>2 = 2400</p> <hr/> <p>3 = 4800</p> <hr/> <p>4 = 9600</p> <hr/> <p>5 = 19200</p>
P28	<p>MODBUS MODE</p>	0 - 2	<p>0 = ENABLED</p> <hr/> <p>1 = ENABLED (WITH SOME SETTINGS TO BE ADJUSTED FROM THE WATER HEATER CONTROL PANEL)</p> <hr/> <p>2 = DISABLED (SET BY DEFAULT)</p>
P29	<p>SETTING THE HEATING TEMPERATURE</p> <p>IN CASE THE BOILER IS INSTALLED AS PART OF A LOW TEMPERATURE CIRCUIT, PLEASE INSTALL A SAFETY THERMOSTAT ON THE HEATING FLOW, WHICH CAN STOP THE BOILER ACTIVITY IN CASE OF HIGH HEATING FLOW TEMPERATURE. THE COMPANY ASSUMES NO LIABILITY FOR DAMAGE CAUSED TO PERSONS OR FOR FAILURE TO COMPLY WITH THESE INSTRUCTIONS.</p>	0 - 1	<p>0 = STANDARD 86-167 °F (30-75 °C) (SET BY DEFAULT)</p> <hr/> <p>1 = REDUCED 77-113 °F (25-45 °C) FOR FLOOR SYSTEMS</p>



PARAMETER	DESCRIPTION	RANGE	FUNCTION
P30	MINIMUM HEATING SETPOINT THROUGH THIS PARAMETER YOU CAN SET THE USER-ADJUSTABLE MINIMUM HEATING TEMPERATURE.	68 - 104	THE VALUE IS EXPRESSED IN °F
P31	MAXIMUM HEATING SETPOINT THROUGH THIS PARAMETER YOU CAN SET THE USER-ADJUSTABLE MAXIMUM HEATING TEMPERATURE.	104 - 160	THE VALUE IS EXPRESSED IN °F
P32	HEATING TIMING THROUGH THIS PARAMETER YOU CAN SET THE MINIMUM TIME FOR WHICH THE BURNER WILL BE TURNED OFF ONCE THE HEATING TEMPERATURE REACHED THE USER SET TEMPERATURE.	0 - 90	VALUE EXPRESSED IN MULTIPLES OF 5 SECONDS (PRE-SET AT 6 X 5 = 30 SECONDS)
P33	HEATING RUN-UP THROUGH THIS PARAMETER YOU CAN SET THE TIME, DURING START-UP PHASE, NECESSARY FOR THE WATER HEATER TO REACH THE MAXIMUM SET POWER (ON THE HEATING SIDE).	0 - 4	0 = (DISABLED) 1 = 50 SECONDS 2 = 100 SECONDS (SET BY DEFAULT) 3 = 200 SECONDS 4 = 400 SECONDS
P34	ENABLING THE SAFETY CHECK, IN CASE OF INSUFFICIENT CIRCULATION UPON THE IGNITION. THE ACTIVATION OF THIS PARAMETER, AGAINST EACH IGNITION OF THE BURNER, LEADS TO THE VERIFICATION OF THE CORRECT OPERATION OF THE CIRCULATING PUMP. SHOULD THE PUMP NOT RUN CORRECTLY, THIS PROTECTS THE HEAT EXCHANGER, AS WELL THE OTHER PARTS THAT MIGHT BE AFFECTED BY THE UN-DISSIPATED HEAT.	0 - 1	0 = DISABLED 1 = ENABLED (SET BY DEFAULT)



2. FIRST START-UP

2.1.6. COMBUSTION BLOWER FREQUENCY/HEAT CAPACITY DIAGRAM

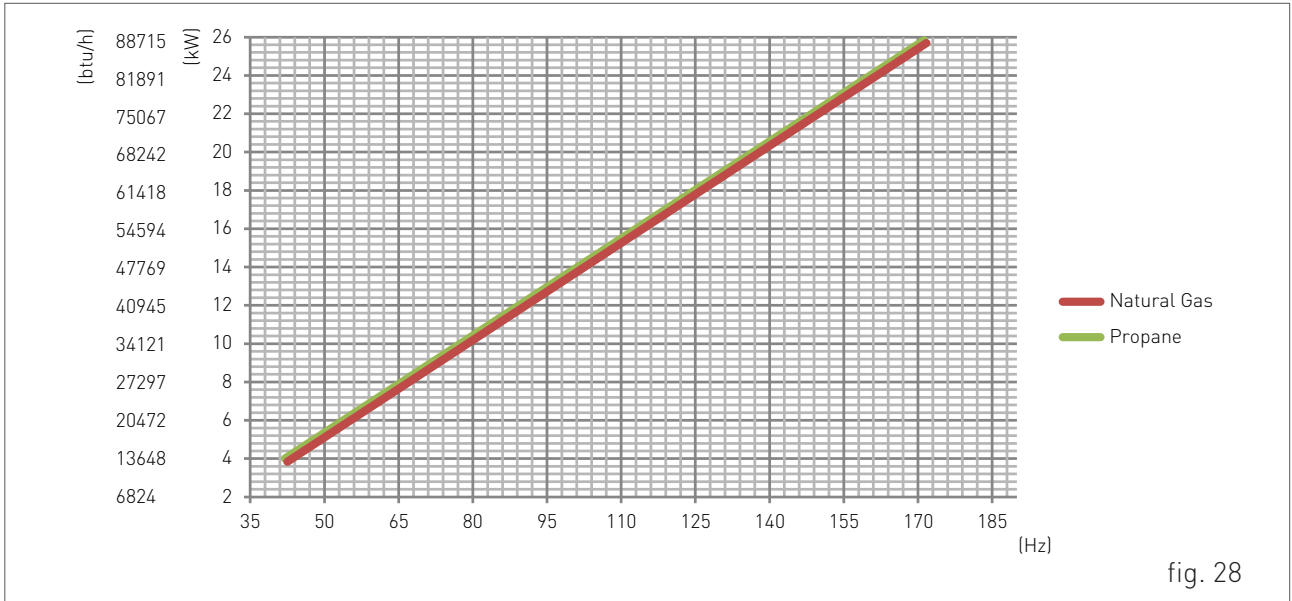

SUPPORT CENTER

GAS TYPE		MINIMUM HEATING FREQUENCY	MAXIMUM HEATING FREQUENCY	MINIMUM FREQUENCY IN DOMESTIC HOT WATER LINE	MAXIMUM FREQUENCY IN DOMESTIC HOT WATER LINE
Natural Gas	Hz	45	172	45	186
Propane	Hz	45	172	45	186

Note: The frequency would change based on vent length. See section '1.1.20 TABLE 1: ALLOWABLE VENT LENGTHS' for change on frequency with feference to vent lengths.



2.2. MAINTENANCE

2.2.7. GENERAL MAINTENANCE WARNINGS



ATTENTION

All maintenance operations must be performed in compliance with standards and subsequent amendments by qualified staff and authorized by RADIANT BRUCIATORI spa.



WARNING

The maintenance operations are recommended to once every twelve months starting from the water heaters installation date.



WARNING

To ensure longer life span and proper operation of the unit, during the maintenance operations use only original spare parts.



DANGER

Before each components cleaning or replacement operation, ALWAYS cut off the POWER, WATER and GAS supply of the water heater.

Please perform the following operations once a year:

- › check the sealing of the water components, and replace the gaskets if necessary;
- › if present, check the pre-load pressure of the D.H.W. expansion tank;
- › check that the wiring is installed in compliance with the requirements in the water heater instruction manual;
- › check the wiring inside the control panel;
- › remove and clean the burner from oxidation;
- › check the integrity and the position of the sealed chamber sealing gasket;
- › check the primary exchanger, if necessary, clean it;
- › check the operation of the gas burner start up and safety systems. If necessary, remove and clean the flame detection and start up electrodes from incrustations paying attention to respect the distances with respect to the burner;
- › check the sealing of the gas components, and replace the gaskets if necessary;
- › visually check the flame and the condition of the combustion chamber;
- › if necessary make sure that the combustion is adjusted correctly and if required proceed as indicated in section "CO2 VALUE CHECK AND CALIBRATION";
- › periodically check the integrity of the venting system for safety and proper operation;
- › make sure that the permanent ventilation outlets are present, correctly sized and functioning, based on the in-installed devices. Follow the requirements provided by Local and National legislation;
- › check the proper operation of the condensate draining system, including the devices outside the water heaters such as condensate collection devices installed along the path of the venting duct or neutralization devices for acid condensate; check that the liquid flow is not obstructed and that there is no combustion gas build up inside the internal sy-stem;
- › check the flow and temperature of domestic hot water.

MAINTENANCE IS MISSING

- › Maintenance procedures:



2. MAINTENANCE

- › Check the vent pipe.
- › Visually inspect the flue gas vent piping monthly for detecting any signs of blockage, leakage or deterioration of the piping. Please contact a qualified service technician immediately if you find any problem.
- › Check the air inlet pipe.
- › Visually inspect the air inlet monthly to be sure it is unobstructed. Inspect entire length of air piping for ensuring that piping is intact, and all joints are properly sealed. Call your qualified service technician if you notice any problems.
- › Check the relief valve.
- › Inspect the Boiler relief valve and the relief valve discharge pipe monthly for any signs of discharge. If the relief valve often discharges, immediately contact your qualified service technician for inspecting the Boiler and system.
- › Check the condensate line.
- › While the Boiler is running, check the discharge end of the condensate drain tubing monthly. Make sure that no flue gas is escaping from the condensate drain tubing. If flue gas is continuously escaping, refill the condensate trap in the appliance. Call your qualified service technician for inspecting the Boiler and condensate line.
- › Check the vent terminal.
- › Visually inspect the terminal screen monthly. Clean the terminal of any debris and call your qualified service technician to replace any parts if needed.
- › Check the air vent.
- › Check the air vents within the appliance to see if they are eliminating air properly and that there is no debris being discharged. Call your qualified technician to replace defective air eliminators..
- › Check the boiler piping (gas and water).
- › Visually inspect for leaks around internal and external water piping every six months. Immediately call a qualified service technician to repair any leaks. Failure to comply with this instruction could result in severe personal injury, death or substantial property damage.
- › Check the burner state.
- › Have a technician inspect the condensate trap, burner and the combustion chamber every six months. A cleaning may be required depending on the usage and dirt during operation of appliance.



2.2.8. TECHNICAL DATA

Model	SFK 57	
Maximum nominal heat capacity in heating circuit	btu/h - (kW)	88716 - (26)
Maximum nominal heat capacity in domestic circuit	btu/h - (kW)	98952 - (29)
Minimum nominal heat capacity in heating circuit	btu/h - (kW)	13650 - (4)
Minimum nominal heat capacity in domestic circuit	btu/h - (kW)	13650 - (4)
Performance at 100% Pn - 140/176°F (60/80°C)	%	98
CO ₂ at nominal heat capacity - Natural Gas	%	9.6 - 9.2
CO ₂ at minimum heat capacity - Natural Gas	%	9.2 - 8.8
CO ₂ at nominal heat capacity - Propane	%	10.6 - 10.2
CO ₂ at minimum heat capacity - Propane	%	10.1 - 9.7
CO at nominal heat capacity	ppm	65 - 150
CO at minimum heat capacity	ppm	1 - 20
Heating circuit		
Adjustable heating temperature	°F - (°C)	86-167 / 77-113 (30-75 / 25-45)
Maximum operating temperature for heating circuit	°F - (°C)	185 - (85)
Maximum operating pressure for heating circuit	psi - (bar)	150 - (10.34)
Minimum operating pressure for heating circuit	psi - (bar)	4.29 - (0.3)
Domestic circuit		
Adjustable domestic temperature	°F - (°C)	104-140 (40-60)
Maximum pressure for domestic circuit	psi - (bar)	150 - (10.34)
Minimum pressure for domestic circuit	psi - (bar)	7.25 - (0.5)
Storage cylinder capacity	gal(US) - (litres)	39.62 - (150)
Continuous hot water supply - ΔT 54°F (30°C) - mixed water - 1 hour	gal(US) - (litres)	251 - (950)
Continuous hot water supply - ΔT 77°F (43°C) - mixed water - 1 hour	gal(US) - (litres)	188 - (711.5)
Continuous hot water supply - ΔT 54°F (30°C) - mixed water	GPM (litres/min)	3.53 (13.36)
Continuous hot water supply - ΔT 77°F (43°C) - mixed water	GPM (litres/min)	2.48 (9.38)
Dimensional characteristics		
Width	in - (mm)	22.4 - (570)
Depth	in - (mm)	23.6 - (600)
Height	in - (mm)	60.11 - (1527)
Gross weight	lb - (Kg)	231.5 - (105)
Water connections		
Flow	∅	3/4" *
Cold water	∅	3/4" *
Hot water	∅	3/4" *
Gas	∅	3/4" *
Return	∅	3/4" *

(*) NOTE: THESE ARE CONNECTION SIZES BEFORE VALVE KIT/CONNECTION CONVERSION KIT IS INSTALLED.



2. MAINTENANCE

Electrical specifications

Voltage-frequency	V/Hz	120/60
Max Absorbed Power	W	75

Gas supply

Nominal supply pressure - Natural Gas	psi - (mbar)	0.25 - (17.4)
Heating Max. fan speed - Natural Gas	Hz	172
D.H.W Max fan speed - Natural Gas	Hz	186
Heating Min. fan speed - Natural Gas	Hz	45
D.H.W Min. fan speed - Natural Gas	Hz	45
Fuel consumption - Natural Gas	ft ³ /h - (m ³ /h)	100.9 - (2.86)
Nominal Supply pressure - Propane	psi - (mbar)	0.47 - (27.4)
Heating Max. fan speed - Propane	Hz	172
D.H.W Max fan speed - Propane	Hz	186
Heating Min. fan speed - Propane	Hz	45
D.H.W Min. fan speed - Propane	Hz	45
Fuel consumption - Propane	lb/h - (kg/h)	4.63 - 2.10



2.2.9. TECHNICAL ASSEMBLY

KEY

1. EXHAUST SAFETY HIGH LIMIT SWITCH
2. HEAT EXCHANGER
3. BURNER UNIT
4. IONIZATION ELECTRODE
5. COMBUSTION BLOWER
6. CONDENSATE COLLECTION SIPHON
7. THERMAL EXPANSION TANK D.H.W.
8. WATER PRESSURE SWITCH
9. ANODE
10. STORAGE TANK
11. TANK DRAINING TAP
12. AIR ELIMINATOR
13. AIR PRESSURE SWITCH
14. DOMESTIC TEMPERATURE PROBE OUTLET
15. WATER TEMPERATURE HIGH LIMIT SWITCH
16. SPARK ELECTRODE
17. DOMESTIC TEMPERATURE PROBE INLET
18. AIR SUCTION TUBE
19. IGNITION TRANSFORMER
20. FLOW METER
21. PROPORTIONAL VENTURI
22. GAS VALVE
23. CIRCULATOR
24. TEMPERATURE AND PRESSURE RELIEF VALVE
25. STORAGE TANK PROBE
26. FLOW SWITCH

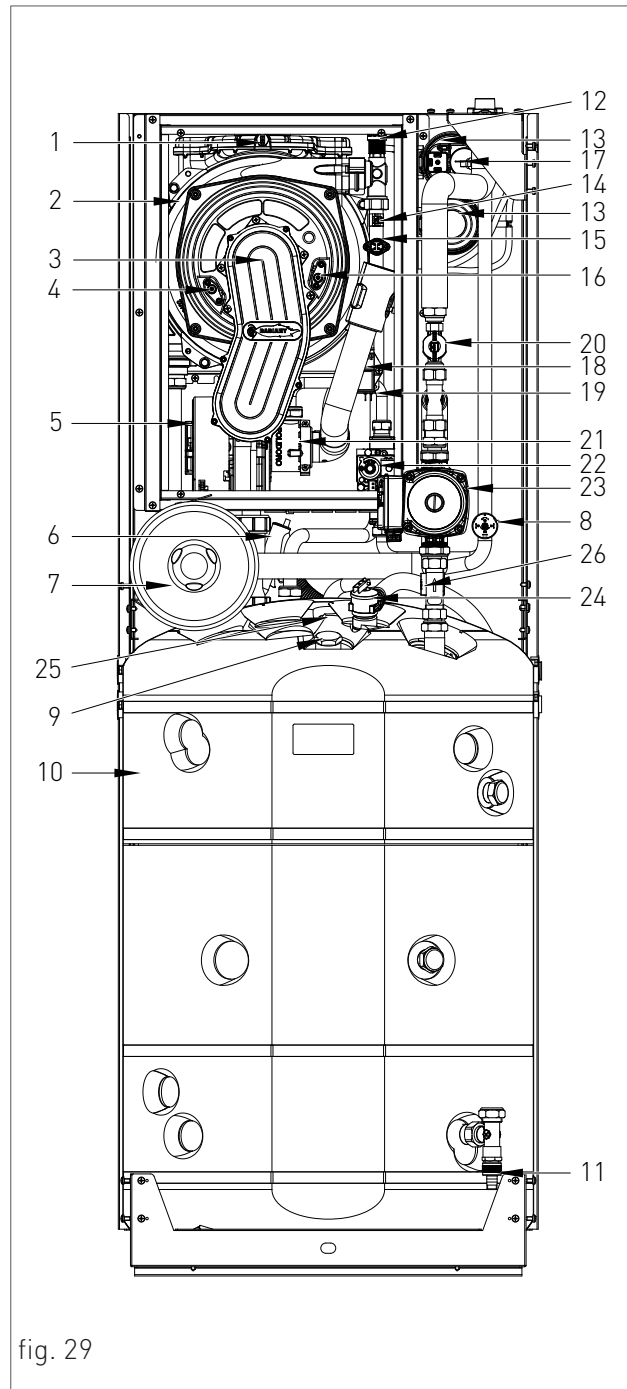

fig. 29

2.2.10. INTERNAL PIPING SCHEMATIC

DRAW DEMAND WITH CIRCULATOR ACTIVE AND WITHOUT RECIRCULATION LINE

KEY

- G. GAS INLET
 - C. DOMESTIC WATER OUTLET
 - F. DOMESTIC WATER INLET
 - SC. CONDENSATE DRAIN
 - RC. RECIRCULATION
 - A. HEATING WATER OUTLET
 - R. HEATING WATER INLET
1. EXHAUST SAFETY HIGH LIMIT SWITCH
 2. HEAT EXCHANGER
 3. BURNER UNIT
 4. COMBUSTION BLOWER
 5. GAS VALVE
 6. CONDENSATE COLLECTION SIPHON
 7. THERMAL EXPANSION TANK D.H.W.
 8. PRESSURE RELIEF VALVE
 9. AIR ELIMINATOR
 10. DOMESTIC TEMPERATURE PROBE OUTLET
 11. WATER TEMPERATURE HIGH LIMIT SWITCH
 12. AIR SUCTION TUBE
 13. PROPORTIONAL VENTURI
 14. DOMESTIC TEMPERATURE PROBE INLET
 15. FLOW METER
 16. CHECK VALVE
 17. CIRCULATOR
 18. WATER PRESSURE SWITCH
 19. ANODE
 20. STORAGE TANK PROBE
 21. STORAGE TANK
 22. TANK DRAINING TAP
 23. FLOW SWITCH

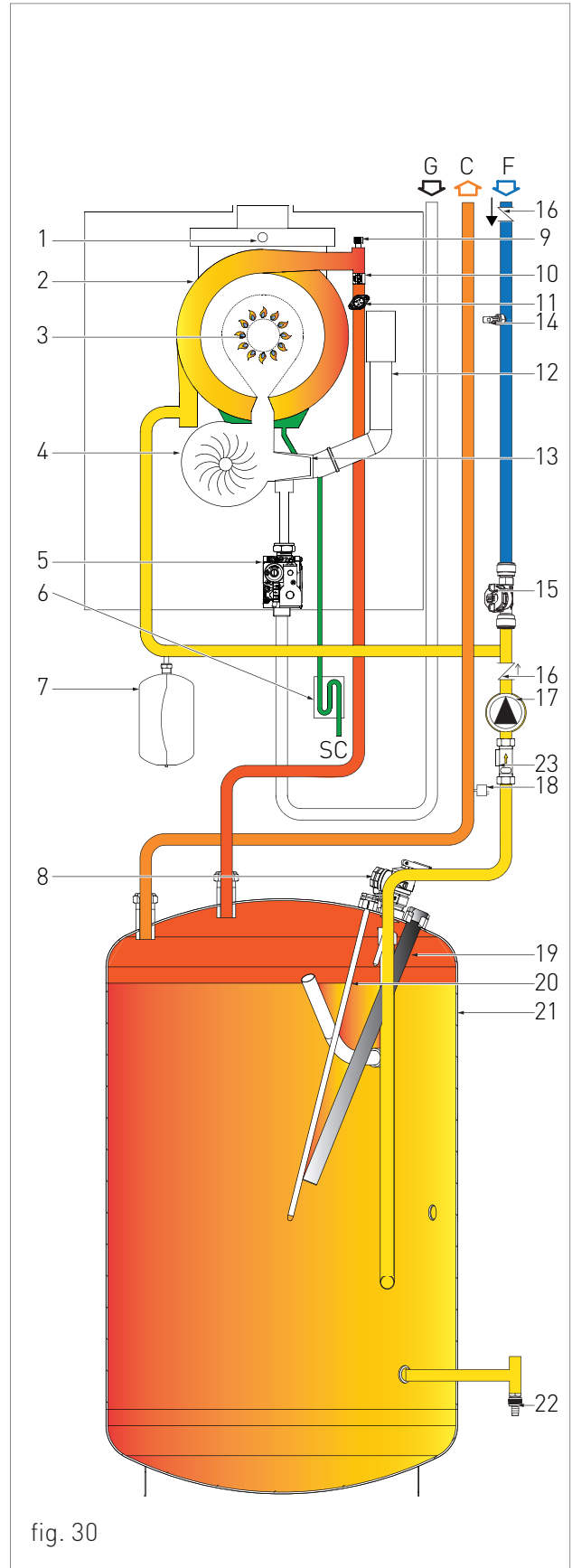
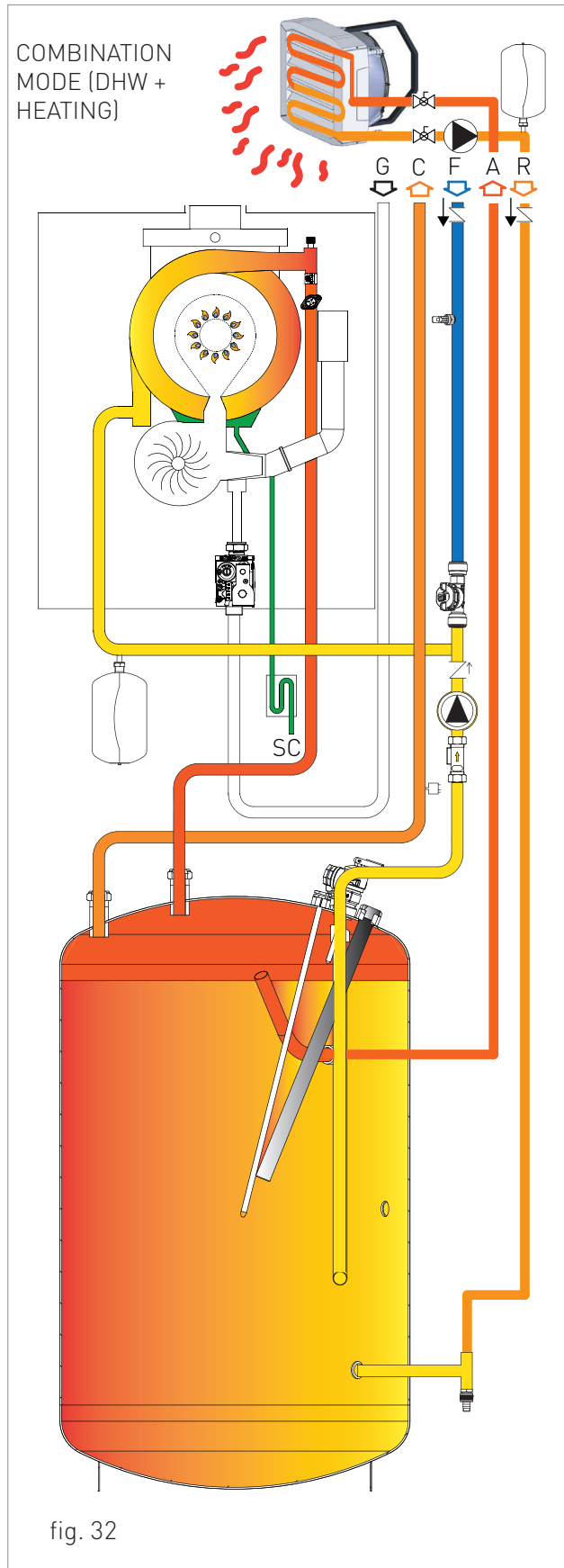
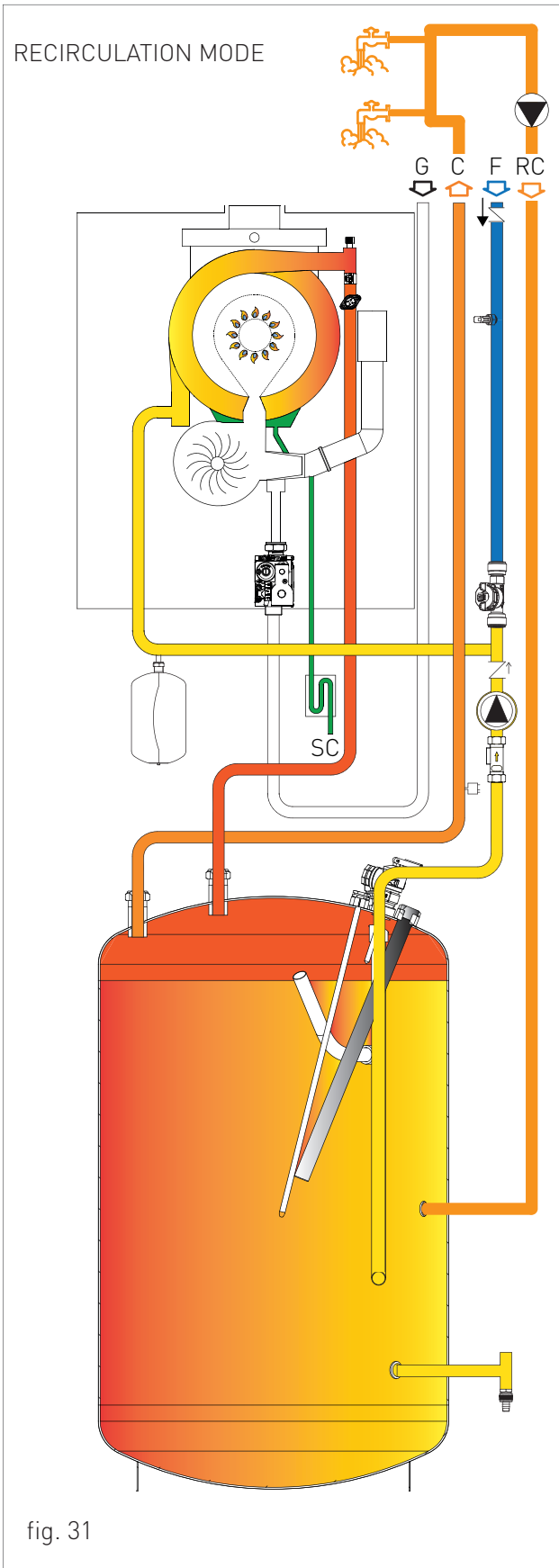

fig. 30



SUPPORT CENTER

2.2.11. WIRING DIAGRAM

CAUTION: Label all wires prior to disconnection when servicing controls. Wiring errors can cause improper and dangerous operation. Verify proper operation after servicing.

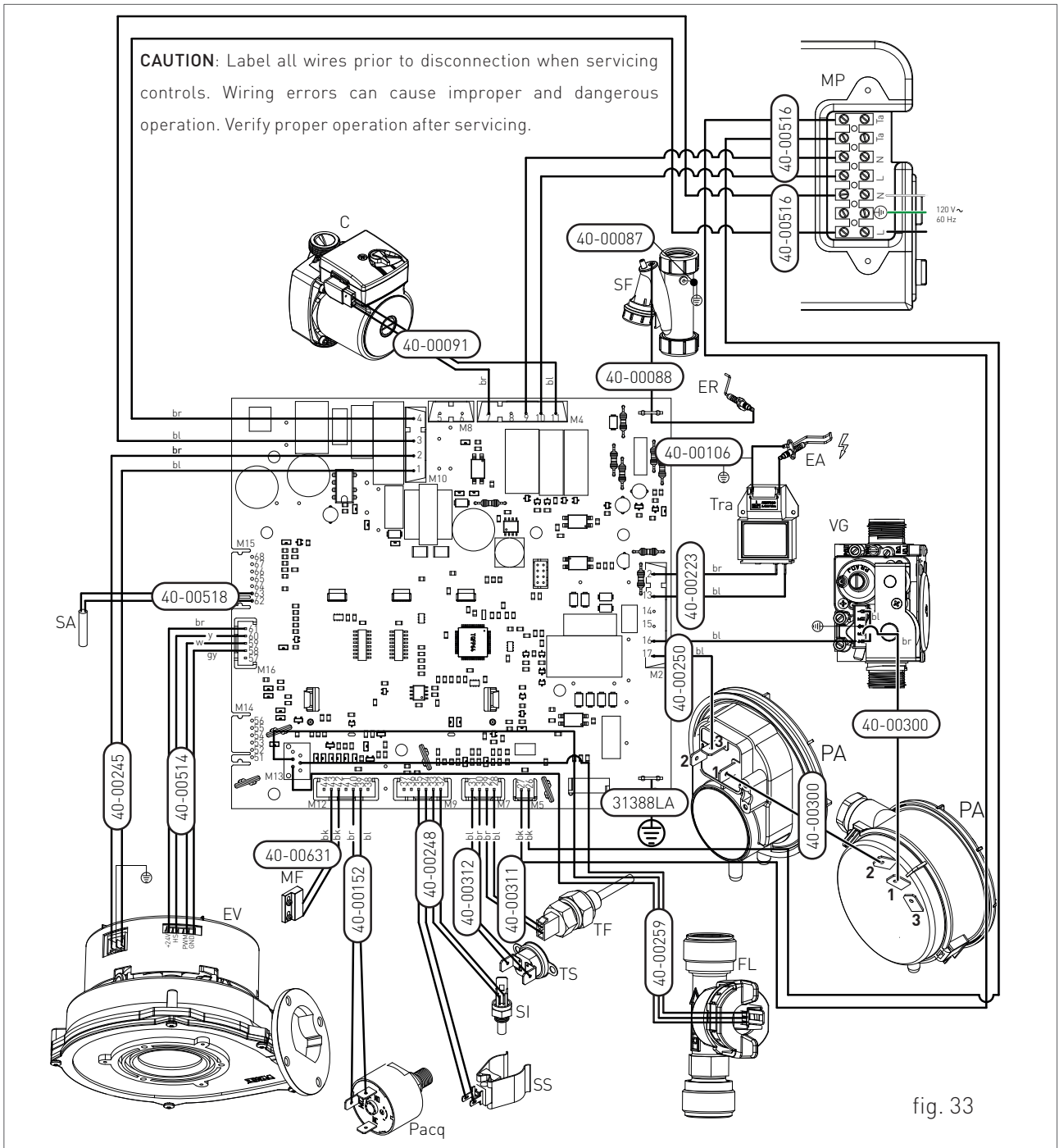

fig. 33

ER: IONIZATION ELECTRODE

EA: SPARK ELECTRODE

C: CIRCULATOR

VG: GAS VALVE

TRA:IGNITION TRANSFORMER

TF: EXHAUST SAFETY HIGH LIMIT SWITCH_(102°C)

SA: STORAGE TANK PROBE

PACQ:WATER PRESSURE SWITCH

MF: FLOW SWITCH

TS: WATER TEMPERATURE HIGH LIMIT SWITCH

FL: FLOW METER

SI: DOMESTIC TEMPERATURE PROBE INLET

SS: DOMESTIC TEMPERATURE PROBE

EV: COMBUSTION BLOWER

PA: AIR PRESSURE SWITCH

SF: CONDENSATE COLLECTION SIPHON

MP: PANEL TERMINAL

L: LINE

N: NEUTRAL

G: GREEN

RE: RED

BK: BLACK

TA: ENVIRONMENT THERMOSTAT

BL: BLUE

BR: BROWN

O: ORANGE

Y: YELLOW

W: WHITE

BK: BLACK

GY: GREY

2.2.12. ACCESSING THE WATER HEATERS

All maintenance and control operations require the water heater casing panels to be removed.

To intervene on water heater casing, please proceed according to the following instructions:

- › remove the fixing screws placed on the front side of the cover '1' (fig. 34) and remove the cover.
- › remove the fixing screws located on the upper side of the cover "2" (fig. 34) and remove the cover by pulling it vertically.
- › remove the fixing screws placed on the front side of the cover '3' (fig. 34) and remove the cover.

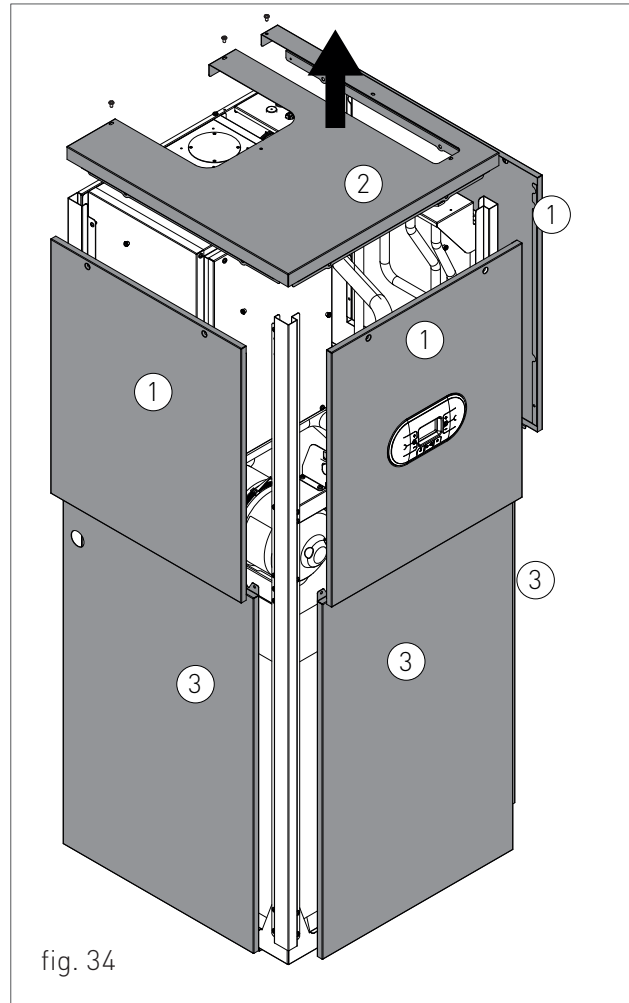

2.2.13. ACCESSING THE ELECTRONIC BOARD

In order to intervene on the wirings of the control panel, please proceed as follows:

**DANGER**

Cut off the voltage from the main switch.

- › Grab at the same time the support brackets of the control panel (fig. 35) loosening them and turn the panel downwards;
- › unscrew the four fastening screws 1 - fig. 35;
- › remove the crankcase pulling it upwards.

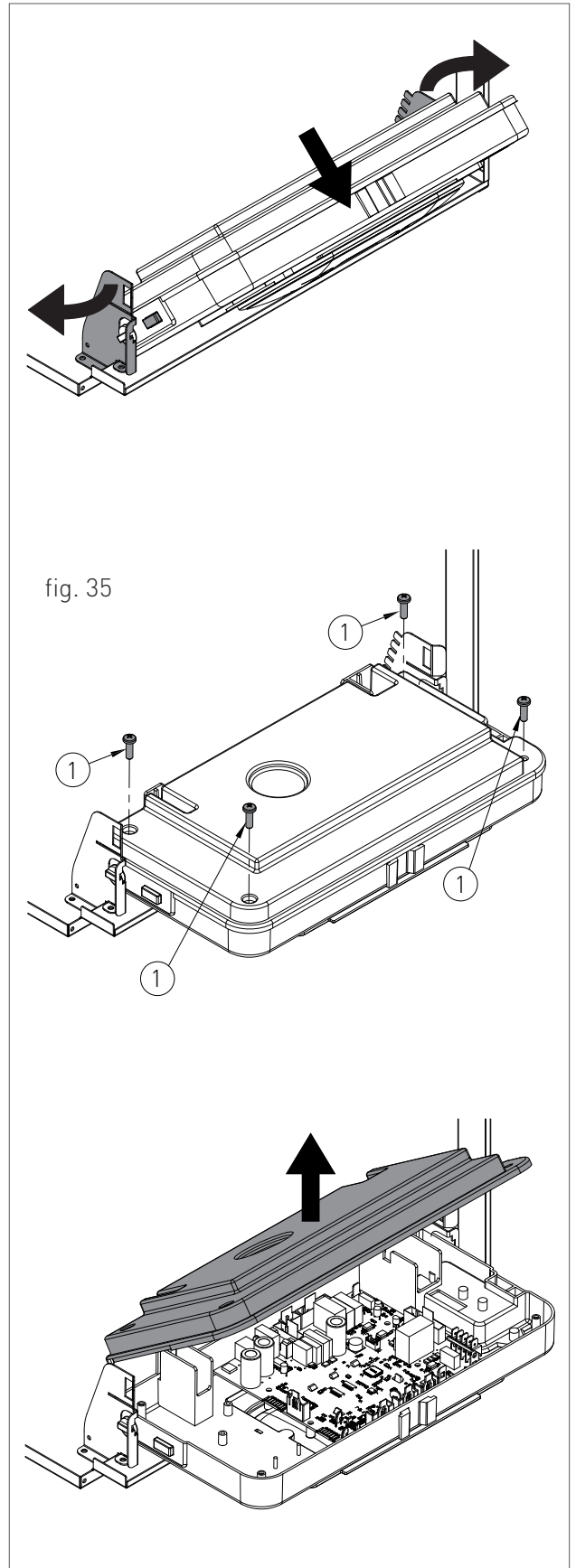



2.2.14. EMPTYING THE DOMESTIC SYSTEM

If there is freezing risk, you have to empty the domestic system as follows:

- › close the main supply tap of the water supply network;
- › open all cold and hot water taps;
- › after completing all operations, close the discharge tap and all previously opened water taps.



2.2.15. FAULT SIGNALLING CODES

To view the last 5 fault signalling codes chronologically, starting with the most recent one, activate the 'OFF' mode by pressing the FUNCTION **MON** key and hold the key INFO **i** for 5 seconds. Use keys **+** and **-** of the heating circuit **III** to scroll through the list of saved faults. To reset the fault history press the RESET **R** key. To exit display mode press the INFO **i** key.

CODE	FAULT	POSSIBLE CAUSE	SOLUTION	RESET
E01	FLAME FAILURE	NO FLAME LIGHT UP		MANUAL RESET (PRESS THE RESET R KEY).
		NO GAS PRESSURE;	CHECK THE GAS SUPPLY;	
		MASS OR BROKEN START-UP ELECTRODE;	REPLACE IT;	
		GAS VALVE NOT OPENING;	REPLACE IT;	
		SLOW LIGHT UP TOO LOW ADJUSTMENT;	ADJUST MINIMUM OR SLOW LIGHT UP;	
		GAS SUPPLY PRESSURE TOO HIGH (ONLY FOR LP WATER HEATERS).	CHECK THE MAXIMUM ADJUSTMENT PRESSURE (60 MBAR W.C. NOT BE EXCEEDED)	
		THE CONDENSATE LINE IS BLOCKED.	CHECK THE CONDENSATE LINE AND EMPTY/CLEAN THE CONDENSATE TRAP.	
		AIR PRESSURE SWITCH TRIPPED	CHECK VENTING, CHECK CABLE, REPLACE PART	
		WITH FLAME LIGHT UP		
		REVERSE POLARITY;	PROPERLY CONNECT THE POWER SUPPLY;	
IONIZATION ELECTRODE BROKEN;	REPLACE IT;			
IONIZATION ELECTRODE CABLE DISCONNECTED.	CHECK THE WIRING.			
E02	WATER TEMP. HIGH LIMIT SWITCH	THERMOSTAT CABLE DISCONNECTED;	CHECK THE WIRING:	MANUAL RESET (PRESS THE RESET R KEY).
		BROKEN HIGH LIMIT.	REPLACE IT.	



CODE	FAULT	POSSIBLE CAUSE	SOLUTION	RESET
E03	EXHAUST SAFETY HIGH LIMIT SWITCH	HIGH LIMIT BROKEN; HIGH LIMIT CABLE DISCONNECTED.	REPLACE IT; CHECK THE WIRING.	MANUAL RESET (PRESS THE RESET  KEY).
E04	LOW WATER CUTOFF	INSUFFICIENT WATER PRESSURE INSIDE THE SYSTEM [LOWER THAN 4.3 PSI (0.3 BAR)] WATER PRESSURE SWITCH CABLE DISCONNECTED; WATER PRESSURE SWITCH BROKEN.	LOAD THE SYSTEM; CHECK THE WIRING; REPLACE IT.	AUTOMATIC.
E05	DOMESTIC INLET TEMP. PROBE (COLD WATER)	BROKEN OR INCORRECTLY CALIBRATED PROBE (RESISTANCE VALUE 10 KOHM AT 77°F (25°C) NTC); DISCONNECTED OR WET PROBE CONNECTOR.	REPLACE IT; CHECK THE WIRING.	AUTOMATIC.
E06	DOMESTIC INLET TEMP. PROBE	BROKEN OR INCORRECTLY CALIBRATED PROBE (RESISTANCE VALUE 10 KOHM AT 77°F (25°C) NTC); DISCONNECTED OR WET PROBE CONNECTOR.	REPLACE IT; CHECK THE WIRING.	AUTOMATIC.
E10	INSUFFICIENT WATER FLOW RATE DURING THE RECIRCULATION FUNCTION	THE FLOW RATE VALUE, READ BY THE FLOWMETER, IS LOWER THAN THE VALUE SET TO THE P17 PARAMETER.	CHECK THAT THE RECIRCULATION PUMP IS WORKING CORRECTLY, IF IT DOES NOT WORK PROPERLY OR IT IS DAMAGED, REPLACE IT.	AUTOMATIC.



2. MAINTENANCE

CODE	FAULT	POSSIBLE CAUSE	SOLUTION	RESET
E12	STORAGE TANK PROBE	BROKEN OR INCORRECTLY CALIBRATED PROBE (RESISTANCE VALUE 10 KOHM AT 77°F (25°C) NTC);	REPLACE IT;	AUTOMATIC.
		DISCONNECTED OR WET PROBE CONNECTOR.	CHECK THE WIRING.	
E15	RECIRCULATION TEMP. PROBE	BROKEN OR INCORRECTLY CALIBRATED PROBE (RESISTANCE VALUE 10 KOHM AT 77°F (25°C) NTC);	REPLACE IT;	AUTOMATIC.
		DISCONNECTED OR WET PROBE CONNECTOR.	CHECK THE WIRING.	
E16	COMBUSTION BLOWER	COMBUSTION BOARD BROKEN;	BLOWER REPLACE IT;	AUTOMATIC.
		COMBUSTION BROKEN;	BLOWER REPLACE IT;	
		FAULTY POWER CABLE.	SUPPLY REPLACE IT.	
E18	INSUFFICIENT CIRCULATION	HEAT EXCHANGER OBSTRUCTED;	CLEAN OR REPLACE THE HEAT EXCHANGER;	AUTOMATIC.
		CIRCULATOR BROKEN OR IMPPELLER.	PUMP DIRTY CLEAN THE IMPELLER OR REPLACE THE CIRCULATOR PUMP.	
E19	LACK OF WATER CIRCULATION	HEAT EXCHANGER OBSTRUCTED;	CLEAN OR REPLACE THE HEAT EXCHANGER;	MANUAL RESET (PRESS THE RESET  KEY).
		CIRCULATOR BROKEN OR IMPPELLER;	PUMP DIRTY CLEAN THE IMPELLER OR REPLACE THE CIRCULATOR PUMP;	
		DEFECTIVE MICRO.	REPLACE IT.	



CODE	FAULT	POSSIBLE CAUSE	SOLUTION	RESET
E21	GENERAL INTERNAL BOARD ERROR	INCORRECT SIGNAL RECOGNITION BY THE MODULATION BOARD MICRO-PROCESSOR.	IF THE MODULATION BOARD DOES NOT RESET THE ERROR AUTOMATICALLY, REPLACE IT.	AUTOMATIC.
E22	PARAMETERS PROGRAMMING REQUEST	MICRO-PROCESSOR MEMORY LOSS.	REPROGRAM PARAMETERS.	MANUAL RESET (DISCONNECT MAIN POWER SUPPLY).
E32	COMMUNICATION ERROR BETWEEN THE WATER HEATER BOARD AND THE MODBUS BOARD	NO ELECTRICAL CONNECTION; MODBUS BOARD BROKEN;	CHECK THE WIRING; REPLACE IT;	AUTOMATIC.
E35	RESIDUAL FLAME	FAULTY IONIZATION ELECTRODE; FAULTY IONIZATION ELECTRODE CABLE; FAULTY MODULATION BOARD.	CLEAN IT OR REPLACE IT; REPLACE IT;	MANUAL RESET (PRESS THE RESET  KEY).
E40	SUPPLY VOLTAGE	SUPPLY VOLTAGE OUT OF OPERATION RANGE	CHECK THE POWER SUPPLY LINE (THE ERROR DEACTIVATES AUTOMATICALLY AS SOON AS THE SUPPLY VOLTAGE FALLS BACK WITHIN THE REQUESTED LIMITS).	AUTOMATIC.
E52	COMMUNICATION FAULT BETWEEN MODBUS CONTROLLER AND MODBUS CONTROL UNIT	NO ELECTRICAL CONNECTION; MODBUS CONTROL UNIT BROKEN.	CHECK THE WIRING; REPLACE IT;	AUTOMATIC.
E56	BLOCKED WATER FLOW CONTROLLER	BLOCKED MAGNET WITHIN THE WATER FLOW CONTROLLER; DEFECTIVE MICRO.	REMOVE ANY DEBRIS THAT MIGHT HAVE BEEN FORMED WITHIN THE WATER FLOW SWITCH; REPLACE IT.	AUTOMATIC.



2. MAINTENANCE

2.2.16. ACTIVE FUNCTIONS SIGNALLING CODES

CODE	FUNCTION	DESCRIPTION
F08	STORAGE TANK ANTI-FREEZE	WHEN THE SANITARY SENSOR DETECTS A TEMPERATURE BELOW 41 °F (5°C), THE PUMP RUNS AND THE BURNER LIFTS UP THE TEMPERATURE TO 86 °F (30°C). WHEN THIS LATTER TEMPERATURE IS ACHIEVED, THE BURNER SHUTS OFF AND THE PUMP RUNS FOR 20 SECONDS AS POST CIRCULATION.
F09	D.H.W CIRCUIT ANTI-FREEZE	WHEN THE SANITARY SENSOR DETECTS A TEMPERATURE BELOW 39.2 °F (4°C), THE PUMP RUNS AND THE BURNER LIFTS UP THE TEMPERATURE TO 46.4 °F (8°C). WHEN THIS LATTER TEMPERATURE IS ACHIEVED, THE BURNER SHUTS OFF AND THE PUMP RUNS FOR 20 SECONDS AS POST CIRCULATION.
F28	ANTI-LEGIONELLA	THE FUNCTION IS ACTIVATED FOR THE FIRST TIME, 60 MINUTES AFTER THAT THE WATER HEATER HAS BEEN ELECTRICALLY POWERED. STARTING FROM THAT MOMENT IT COMES AUTOMATICALLY INTO OPERATION EVERY 7 DAYS, BRINGING THE HOT WATER TEMPERATURE OF THE STORAGE CYLINDER UP TO 140°F (60°C). THIS FUNCTION IS ENABLED INDEPENDENTLY FROM THE CONTACT TO THE CYLINDER CLOCK, PROVIDING THAT THE RELATIVE PARAMETER (P15) IS ENABLED.



2.2.17. POSITIONS OF THE ELECTRODES

If the water heaters does not restart, check the positions of the electrodes (especially the ignition electrode).

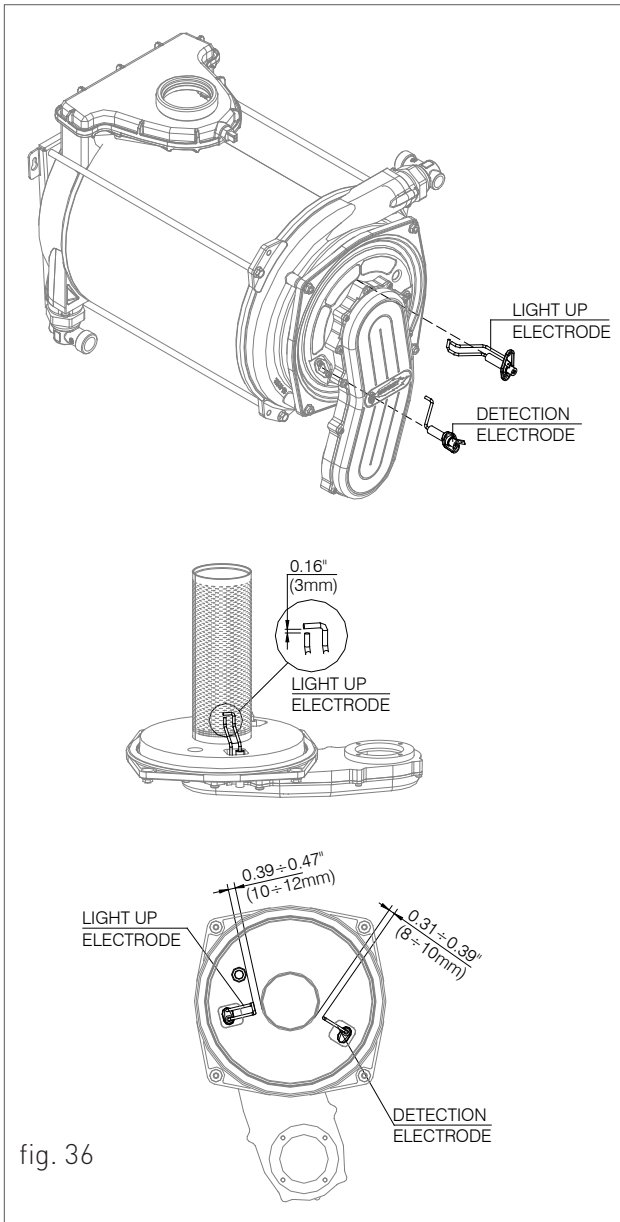

2.2.18. CONVERSION TO A DIFFERENT GAS TYPE



ATTENTION

Make sure that the gas induction tube is suitable for the new type of fuel with which the water heaters is supplied.

FOR CONVERSION PROCEED AS FOLLOWS:

- › loosen the two screws '1' (fig. 37) from the fastening bush, and remove the air suction tube;
- › unscrew the tube coupling that connects the gas valve to venturi;
- › unscrew the three fastening screws '2' (fig. 37) of the venturi 'V' (fig. 37) using a 10 key, as shown in figure 38;
- › remove the two screws '3' (fig. 39) and apply pressure on the rear side of venturi 'C' (fig. 39);
- › replace the venturi with the one suitable for the type of supply gas (cod. 30-00227 for NATURAL GAS / cod. 30-00228 for PROPANE), and make sure the tooth 'D' (fig.39) is adjusted downwards on the aluminium ring nut (see fig.39);
- › remount the components following the demounting operations in reverse making sure that gasket 'G' is re-assembled as shown in fig. 37;
- › set the water heater to operate with the new type of gas, changing the value of the parameter P02 'GAS TYPE SELECTION' from the control panel (see 2.1.5 and 2.1.4 'DIGITECH CS PARAMETERS TABLE' and 'ACCESSING AND PROGRAMMING THE PARAMETERS');
- › adjust the CO₂ combustion value as indicated in 2.1.3 'CO₂ VALUE CHECK AND CALIBRATION'.

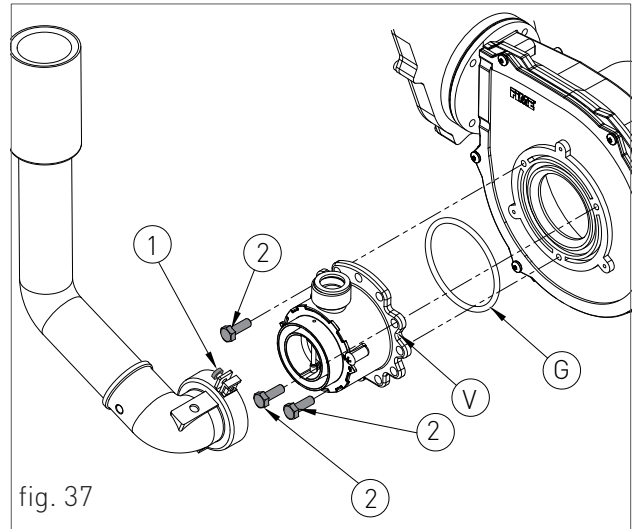

fig. 37

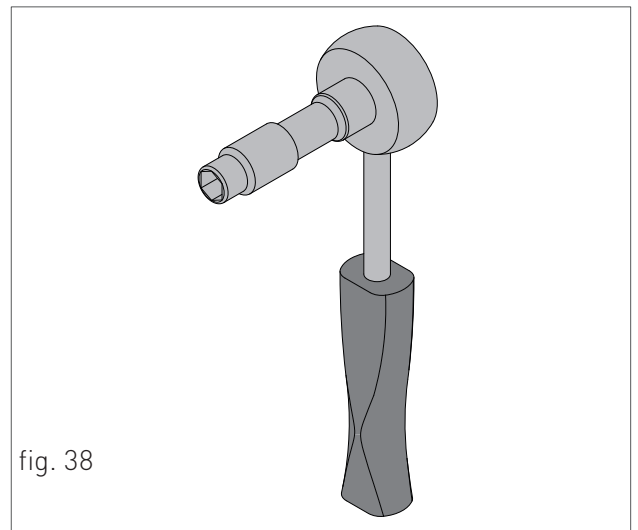

fig. 38

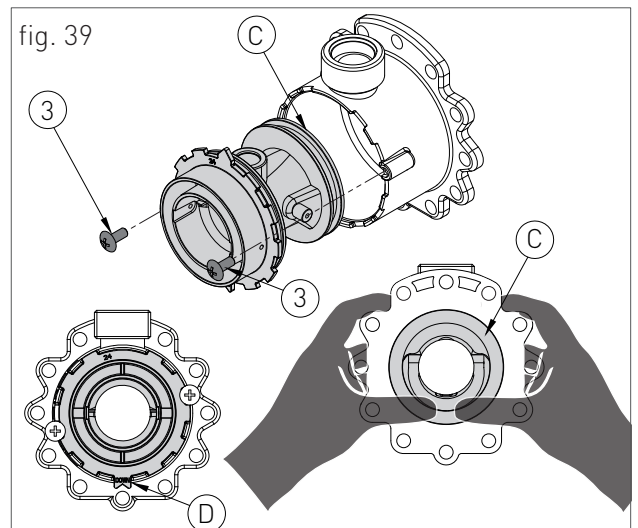

fig. 39



2.2.19. BOILER MAINTENANCE

Please have the anode checked on a regular basis.

The anode has to be checked at least once every year and, if necessary, it has to be replaced to protect the storage tank.

Should the mains water be particularly hard and aggressive, it might be necessary to have it checked two times per year.

In order to check the anode functioning it's necessary to open the cap 'B' (fig.40) situated on the top of the boiler.

If during this operations there is a water leak, the anode has to be replaced because worn.

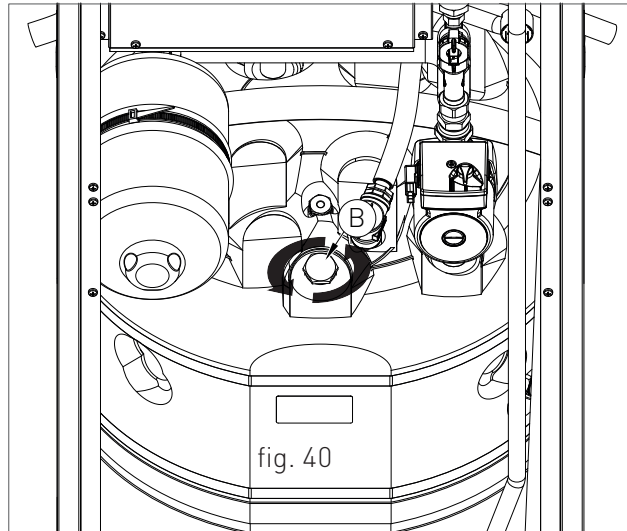



RADIANT BRUCIATORI s.p.a.

Via Pantanelli, 164/166 - 61025 Loc. Montelabbate (PU)

Tel. +39 0721 9079.1 • fax. +39 0721 9079279

e-mail: info@radiant • Internet: <http://www.radiant.it>