

R2K 34

Submittal



R2K 34 is a premier premix gas-fired condensing combination boiler that complies with ANSI Z21.13 and CSA 4.9 GAS FIRED LOW PRESSURE STEAM AND HOT WATER BOILERS. The R2K 34 is equipped with Radiant's Combi-Tech® stainless steel heat exchanger that consists of a single tube coil with a diameter of 28 mm. This larger coil tube reduces the pressure drop across the heat exchanger, and prevents debris/limestone deposits and makes it much easier on maintenance. The R2K 34 model features a 1:9 air/gas modulation which is important for energy savings and prevents frequent cycling of the boiler.

MAIN FEATURES

ANTI-FREEZE FUNCTION PROTECTION

OUTDOOR RESET

WIDE MODULATING RANGE

LOW NOX EMISSIONS

AUTOMATIC BY-PASS FITTED

PRE-WIRED ELECTRICAL LEAD

FULL GAS/AIR MODULATION

MIXED ZONE CARD (OPTIONAL)

SOLAR CARD CONTROL (OPTIONAL)

TIME AND TEMPERATURE CONTROLLERS (OPTIONAL)

TECHNICAL FEATURES

MODEL		R2K 34
Maximum central heating input	btu/h - (kW)	116013 - (34)
Maximum domestic hot water input	btu/h - (kW)	116013 - (34)
Minimum central heating input	btu/h - (kW)	15013 - (4.4)
Minimum domestic hot water input	btu/h - (kW)	15013 - (4.4)
Adjustable central heating range	°F - (°C)	86-176 / 77-113 (30-80 / 25-45)
Maximum operating temperature for central heating	°F - (°C)	203 - (95)
Maximum operating pressure for central heating	psi - (bar)	60 - (4.1)
Capacity of the system expansion vessel	gal(US) - (litres)	2.11 - (8)
Domestic hot water temperature range	°F - °C	95-140 (35-60)
Maximum pressure for domestic hot water	psi - (bar)	150 - (10.34)
Minimum pressure for domestic hot water	psi - (bar)	7.25 - (0.5)
Continuous hot water flow rates: ΔT 54°F (30°C)	gal(US) - (litres)	4.29 - (16.24)
Continuous hot water flow rates: ΔT 77°F (43°C)	gal(US) - (litres)	2.99 - (11.32)
Width	in - (mm)	16.1 - (410)
Depth	in - (mm)	12.9 - (330)
Height	in - (mm)	25.27 - (642)
Gross weight	lb - (Kg)	97 - (44)
Electric consumption - normal	W	78
Electric consumption - Standby	W	3.5
AFUE	%	96

WARRANTY HEAT EXCHANGER: 12 YEARS;

WARRANTY COMPONENTS: 2 YEARS.

PROJECT NO.:

REPRESENTATIVE:

NAME:

DATE:

LOCATION:

SPECIFIER:

APPROVED BY:

CONTRACTOR:

DATE:



OVERALL DIMENSIONS (INCH)

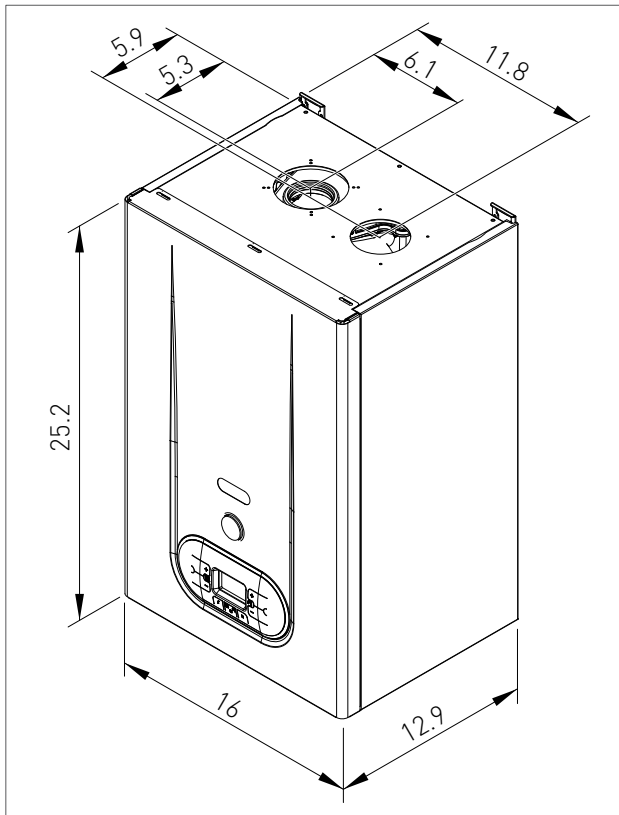

TYPES OF EXHAUST SYSTEMS

- > COLLINEAR VENT, CO-AXIAL VENT AND SINGLE VENT.
- > PVC, CPVC AND POLYPROPYLENE FOR SIZES 2", 3" AND 4" DIAMETERS.
- > FOR CANADA USE GAS VENTING SYSTEMS CERTIFIED TO ULC S636.

CIRCULATOR PREVALENCE/FLOW DIAGRAM

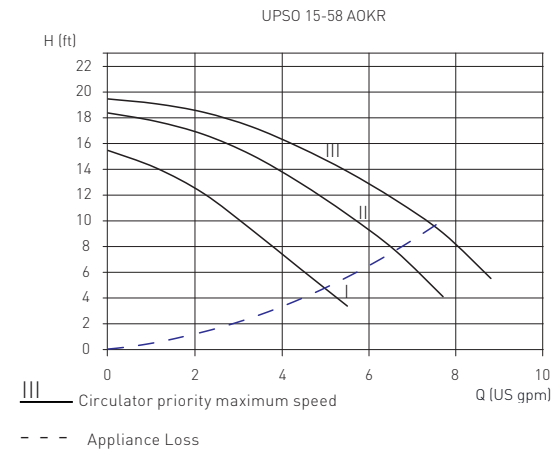

JIG

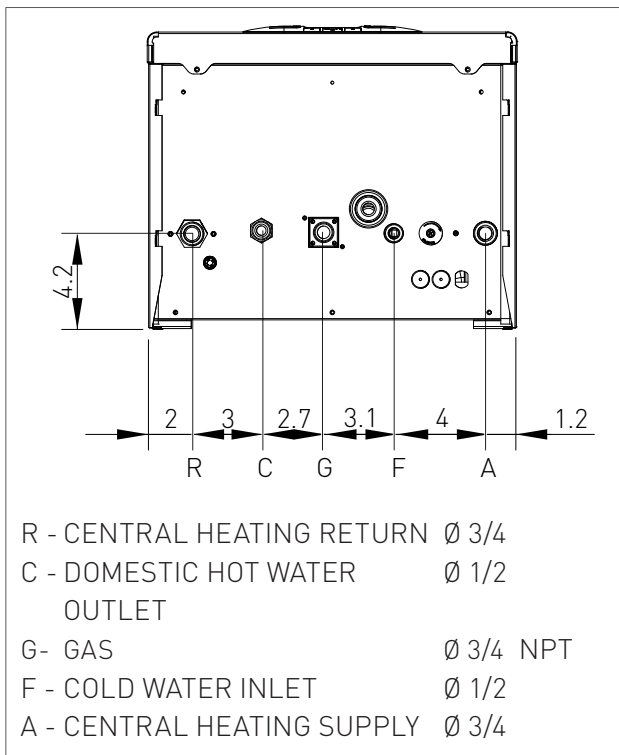

PRESSURE RELIEF VALVE KIT

An hydraulic kit equipped with hydraulic connections and safety valve (see 'VS') is available and supplied by RADIANT.

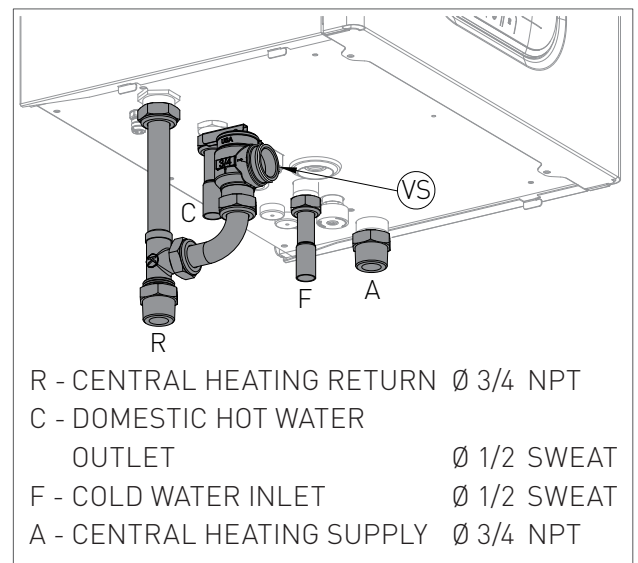

TECHNICAL ASSEMBLY

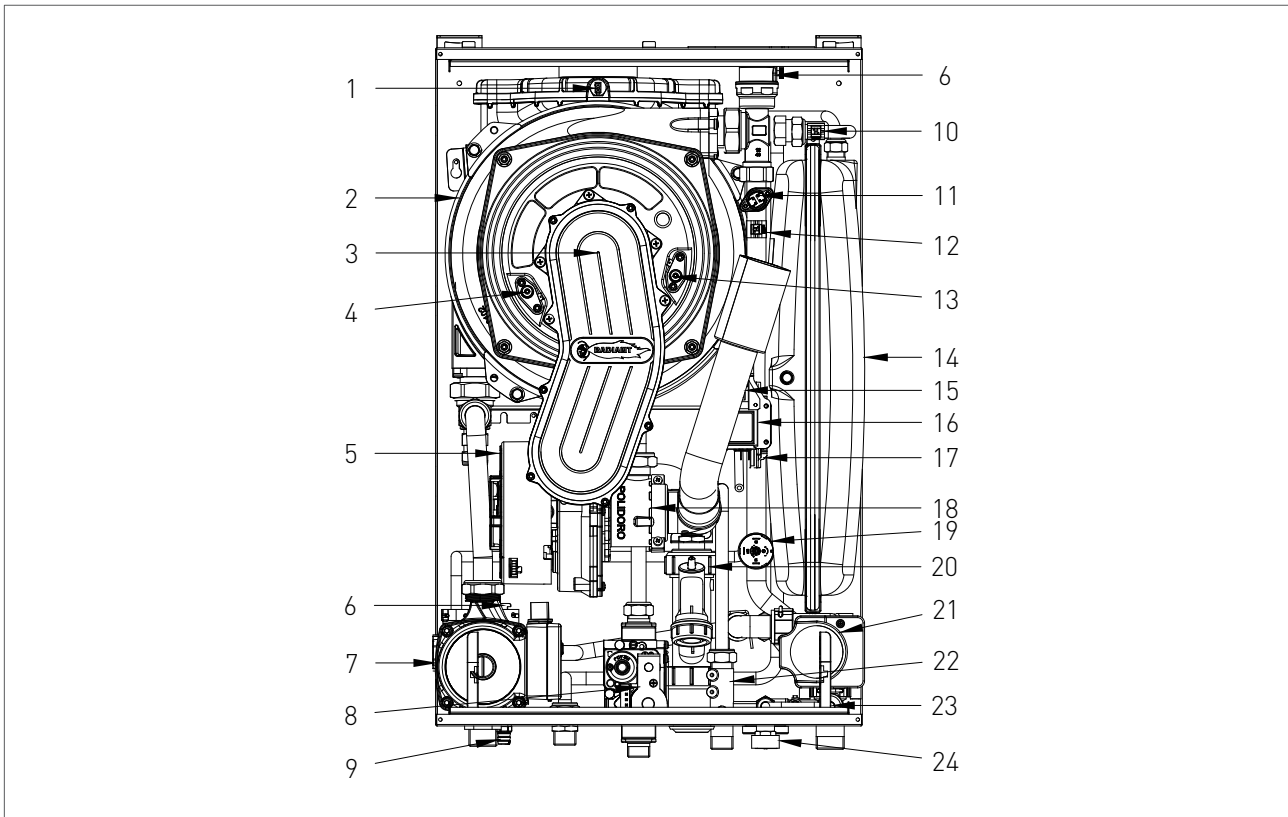

KEY

- | | |
|-----------------------------------------|------------------------|
| 1. EXHAUST SAFETY HIGH LIMIT SWITCH | 23. CHECK VALVE |
| 2. INTEGRATED HEAT EXCHANGER | 24. SYSTEM FILLING TAP |
| 3. BURNER UNIT | |
| 4. IONIZATION ELECTRODE | |
| 5. COMBUSTION BLOWER | |
| 6. AIR ELIMINATOR | |
| 7. CIRCULATOR | |
| 8. GAS VALVE | |
| 9. SYSTEM DRAINING TAP | |
| 10. DOMESTIC TEMPERATURE PROBE | |
| 11. WATER TEMPERATURE HIGH LIMIT SWITCH | |
| 12. CENTRAL HEATING TEMPERATURE PROBE | |
| 13. SPARK ELECTRODE | |
| 14. THERMAL EXPANSION TANK | |
| 15. AIR SUCTION TUBE | |
| 16. IGNITION TRANSFORMER | |
| 17. AIR PRESSURE SWITCH | |
| 18. PROPORTIONAL VENTURI | |
| 19. WATER PRESSURE TRANSDUCER | |
| 20. CONDENSATE COLLECTION SIPHON | |
| 21. DIVERTER VALVE | |
| 22. FLOW SWITCH | |

HYDRAULIC BOARD

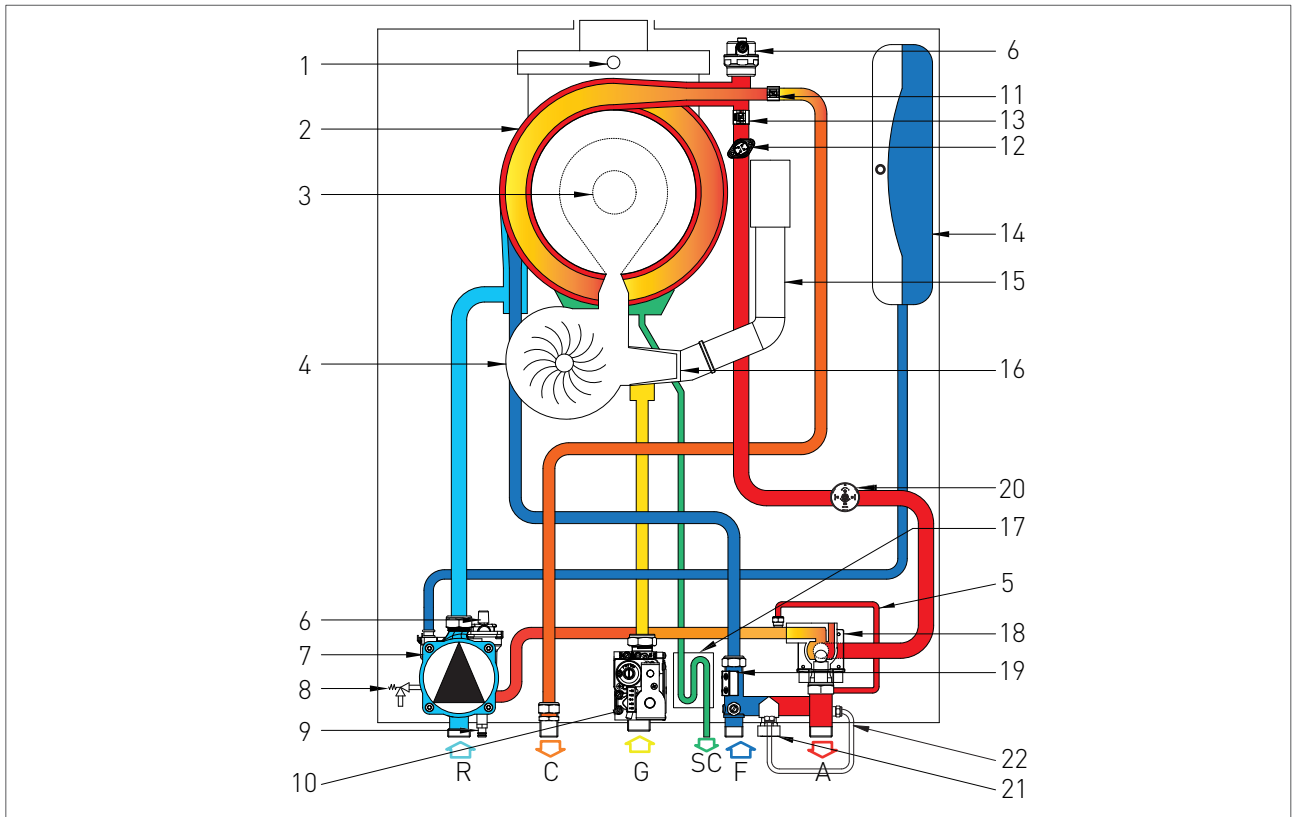

KEY

- | | |
|-------------------------------------|-----------------------------------------|
| R. CENTRAL HEATING RETURN | 8. PRESSURE RELIEF VALVE 30 psi (2 bar) |
| C. DOMESTIC HOT WATER OUTLET | 9. SYSTEM DRAINING TAP |
| G. GAS INLET | 10. GAS VALVE |
| SC. CONDENSATE DRAIN | 11. DOMESTIC TEMPERATURE PROBE |
| F. COLD WATER INLET | 12. WATER TEMPERATURE HIGH LIMIT SWITCH |
| A. CENTRAL HEATING SUPPLY | 13. CENTRAL HEATING TEMPERATURE PROBE |
| 1. EXHAUST SAFETY HIGH LIMIT SWITCH | 14. THERMAL EXPANSION TANK |
| 2. INTEGRATED HEAT EXCHANGER | 15. AIR SUCTION TUBE |
| 3. BURNER UNIT | 16. PROPORTIONAL VENTURI |
| 4. COMBUSTION BLOWER | 17. CONDENSATE COLLECTION SIPHON |
| 5. BY-PASS | 18. DIVERTER VALVE |
| 6. AIR ELIMINATOR | 19. FLOW SWITCH |
| 7. CIRCULATOR | 20. WATER PRESSURE TRANSDUCER |
| | 21. SYSTEM FILLING TAP |
| | 22. CHECK VALVE |



WIRING DIAGRAM

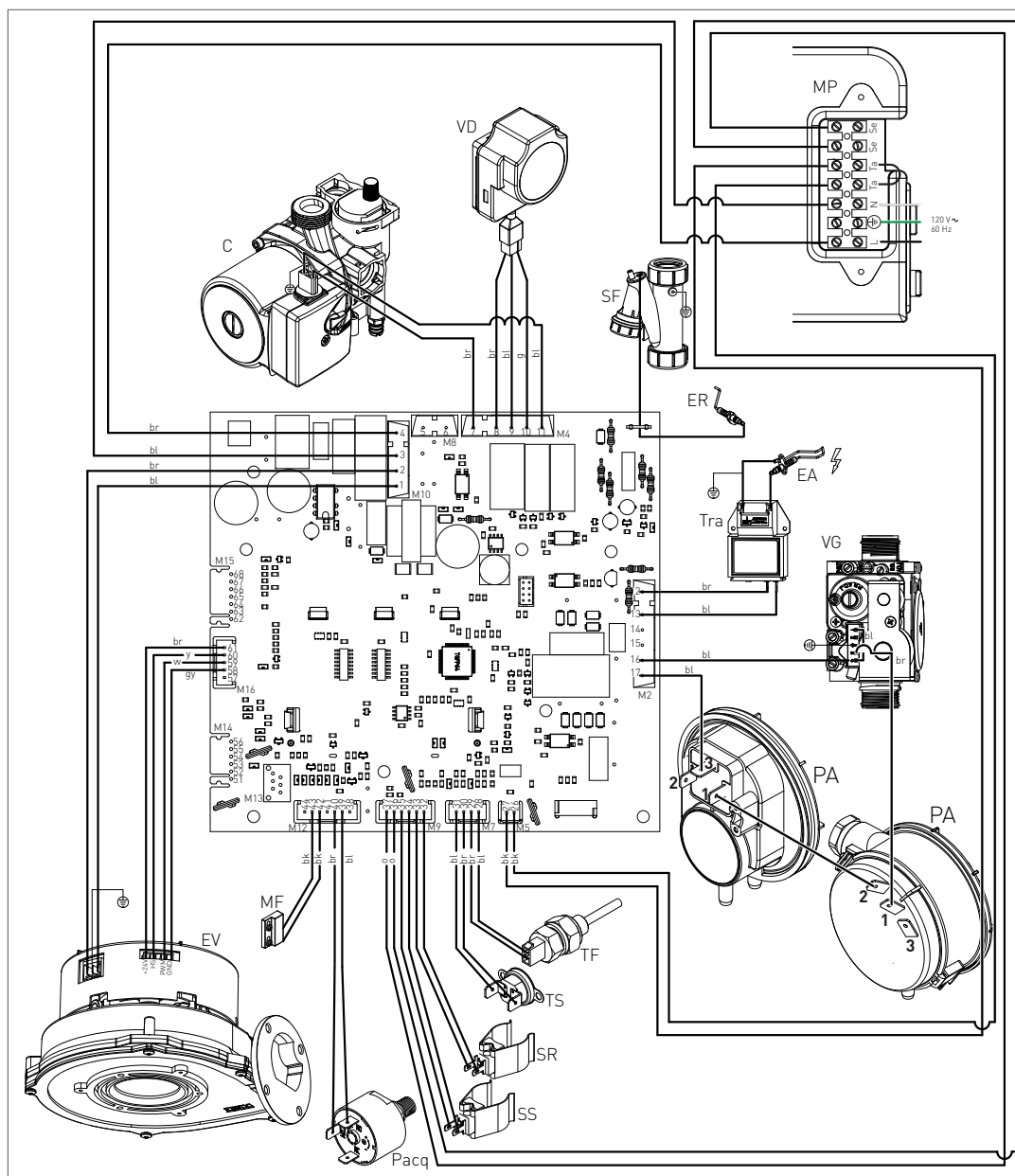

ER: IONIZATION ELECTRODE	TS: WATER TEMPERATURE HIGH LIMIT SWITCH	MP: PANEL TERMINAL	BL: BLUE
EA: SPARK ELECTRODE	PACQ: WATER PRESSURE TRANSDUCER	SE: OUTDOOR TEMPERATURE	BR: BROWN
C: CIRCULATOR	MF: MICRO-FLOW SWITCH	TA: ENVIRONMENT THERMOSTAT	O: ORANGE
VG: GAS VALVE	SR: CENTRAL HEATING TEMPERATURE PROBE	L: LINE	Y: YELLOW
TRA: IGNITION TRANSFORMER	SS: DOMESTIC TEMPERATURE PROBE	N: NEUTRAL	W: WHITE
TF: EXHAUST SAFETY HIGH LIMIT SWITCH (102°C)	EV: COMBUSTION BLOWER	BK: BLACK	GY: GREY
VD: DIVERTER VALVE	PA: AIR PRESSURE SWITCH	G: GREEN	SF: CONDENSATE COLLECTION SIPHON